

Instrumentation and Controls

Section 9A - Instrumentation and Controls

Table of Contents

Instrumentation.....	9A-2	Installation.....	9A-11
Requirements and Recommendations.....	9A-2	Dual Station (Helm) Cable Setup.....	9A-12
Important Installation Information.....	9A-2	Cable Attachment Hardware.....	9A-13
Accessory Connections.....	9A-3	Cable Adjustment.....	9A-15
Dual Station Instrumentation.....	9A-3	Motoviewer.....	9A-17
Engine Guardian System.....	9A-4	MotoViewer Service Tool.....	9A-17
Lanyard Stop Switch Information.....	9A-4	Saving Special Functions.....	9A-18
Boat Harness.....	9A-6	Clearing Fault History.....	9A-18
Instrumentation Harness Receptacle.....	9A-8	Setting Engine Location.....	9A-19
14-Pin Engine—Analog Gauge Harness		AutoSync.....	9A-20
.....	9A-9	Trim and Trailer Limit.....	9A-21
14-Pin Engine Harness Connector.....	9A-10	Configuring EZLink Gauges (TachLink)	
Remote Control and Cables.....	9A-10	9A-25
Requirements and Recommendations..	9A-10	Other Special Functions.....	9A-26

Lubricant, Sealant, Adhesives

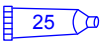
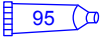
Tube Ref No.	Description	Where Used	Part No.
 25	Liquid Neoprene	Electrical connections	92- 25711 3
 95	2-4-C with Teflon	Cable guides and pivot points	92-802859A 1

Instrumentation

Requirements and Recommendations

IMPORTANT: This section includes information on Quicksilver's standard (non-digital) instrumentation and mechanical (cable-actuated) remote controls. Refer to the Smart Craft applications manual for information on Mercury's new digital instrumentation and remote controls.

Mercury MerCruiser inboard and tow sports engines, designed to comply with the ABYC Standards, use the four basic gauges shown below:

- Tachometer
- Oil pressure
- Water temperature
- Voltmeter (battery charge indicator)

An extensive array of Quicksilver gauges, instrumentation harnesses, extension harnesses, and related accessories are available through Mercury Precision Parts to satisfy your instrumentation needs. We recommend the use of Quicksilver instrumentation because they are specifically designed for compatibility with our engines, and engineered to the same high quality and performance standards. Refer to the **Mercury Precision Parts Accessories Guide** for a complete list. Wiring diagrams of some of the basic instrumentation configurations are provided at the end of this section.

Important Installation Information

Instrumentation should be installed in accordance with the instructions that accompany them.

IMPORTANT: When designing and installing the instrumentation, adhere to the applicable boating industry standards and regulations (NMMA, ABYC, SAE, USCG, EUs, RCD, ISO, etc.) for the markets where the boat will be sold.

- Ensure that harnesses are routed to avoid getting pinched or chafed.
- Avoid routing the harness in an area where it could be damaged or short circuited later in the assembly process, such as when a screw is inserted or a hole is drilled.

IMPORTANT: Harness receptacles can be damaged by overtightening clamps.

- The cannon plug connection on the extension harness (at engine and dash) must be secured with a hose clamp to avoid a loose connection or water entry.
- Support harness every 46 cm (18 in.) using industry approved fasteners. (ABYC Standard)
- Coat exposed connections on gauges with liquid neoprene to avoid corrosion.

Tube Ref No.	Description	Where Used	Part No.
 25	Liquid Neoprene	Electrical connections	92- 25711 3

Accessory Connections

⚠ CAUTION

Failure to protect wiring with an appropriate fuse can damage the wiring and start a fire. When installing any accessories, we recommend using a Mercury accessory kit. Always use the appropriate fuse to protect wiring.

⚠ CAUTION

Failure to protect wiring with an appropriate fuse can damage the wiring and start a fire. When installing any accessories, we recommend using a Mercury accessory kit. Always use the appropriate fuse to protect wiring.

IMPORTANT: The accessory wire in the 14-pin harness will not support amperage in excess of 15-amps. For protection, the main power relay fuse may blow if an excess of 15-amps is applied. Refer to the Mercury Precision Parts Accessories Guide for an optional accessory power relay kit that will accommodate higher amperage draw.

A fused accessory panel with up to a 40-amp current draw can be connected to the helm harness. On dual station applications, the combined current draw for both stations must not exceed 40 amps. If optional accessory power relay kits are installed, the combined current draw for both stations must not exceed 40 amps per kit. Each helm harness may support up to two accessory power relay kits. The boat manufacturer is responsible for ensuring that the accessory connections are made in accordance with the industry standards and regulations. See information under **Industry Standards and Regulations**.

Dual Station Instrumentation

Instrumentation and harnesses are available through Mercury Precision Parts and Accessories to accommodate dual station (helm) applications (see wiring diagram for typical installation). When oil pressure and water temperature gauges are used at both stations, dual station oil pressure and temperature senders must be installed on the engine to obtain the proper gauge readings. Refer to the **Mercury Precision Parts and Accessories Guide** for part numbers.

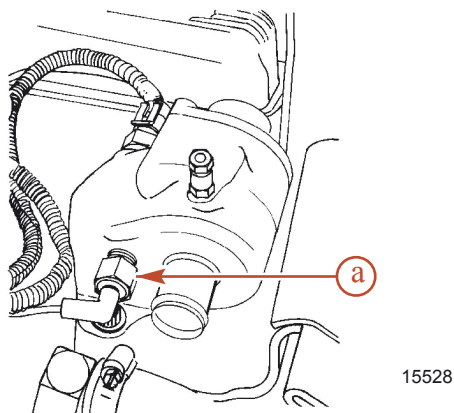

a - Typical coolant temperature sender

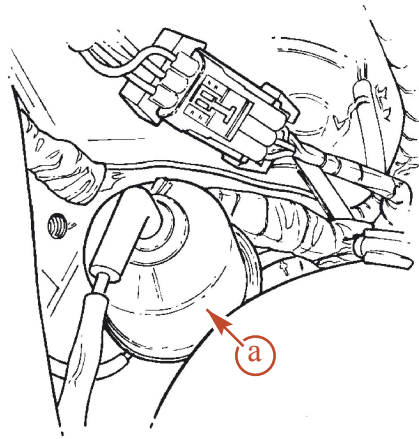

15529

a - Typical oil pressure sender

Engine Guardian System

The Engine Guardian System monitors the critical sensors on the engine for any early indications of problems. The system will respond to a problem by emitting a continuous beep and/or reducing engine power in order to provide engine protection.

If Guardian System has been activated, reduce throttle speed. The horn will turn off when throttle speed is within the allowable limit. Consult an authorized Mercury MerCruiser dealer for assistance.

Lanyard Stop Switch Information

⚠ WARNING

Avoid serious injury or death from deceleration forces resulting from accidental or unintended stop switch activation. The boat operator should never leave the operator's station without first disconnecting the stop switch lanyard from the operator.

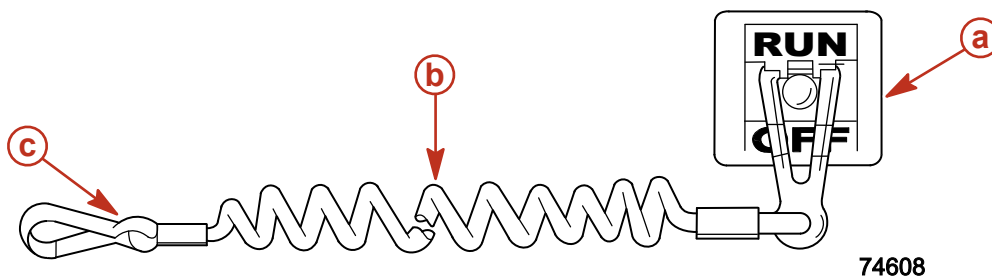

a - Stop switch
b - Lanyard

c - Clips to operator

The purpose of a lanyard stop switch is to turn off the engine when the operator moves outside the operator's position (as in accidental ejection from the operator's position).

Accidental ejections, such as falling overboard, are more likely to occur in:

- low sided sport boats.
- bass boats.
- high-performance boats.

Accidental ejections can also occur from:

- following poor operating practices.
- sitting on the seat or gunwale at planing speeds.

- standing at planing speeds.
- operating the boat at planing speeds in shallow or obstacle infested waters.
- releasing your grip on the steering wheel while it is pulling in one direction.
- consuming alcohol or drugs.
- maneuvering the boat at high speeds.

Some remote control units are equipped with a lanyard stop switch. If your remote control is not equipped with a lanyard stop switch, one can be installed on the dashboard or side adjacent to the operator's position. The lanyard is a cord usually 1.2–1.5 m (4–5 ft.) long when stretched out with an element on one end made to be inserted into the switch and a snap on the other end for attaching to the operator. The lanyard is coiled to make it as short as possible to minimize the likelihood of entanglement with nearby objects. It stretches to minimize the likelihood of accidental activation should the operator choose to move around in an area close to the normal operator's position. If it is desired to have a shorter lanyard, wrap the lanyard around the operator's wrist or leg or tie a knot in the lanyard.

While activation of the lanyard stop switch will stop the engine immediately, the boat will continue to coast for some distance depending upon the velocity and degree of any turn at shut-down. However, the boat will not complete a full circle. While the boat is coasting, it can cause injury to anyone in the boat's path as seriously as the boat would when under power.

We strongly recommend that other occupants be instructed on proper starting and operating procedures should they be required to operate the engine in an emergency (e.g. if the operator is ejected).

 **WARNING**

If the operator falls out of the boat, stop the engine immediately to reduce the possibility of serious injury or death from being struck by the boat. Always properly connect the operator to the stop switch using a lanyard.

Accidental or unintended activation of the switch during normal operation is also a possibility. This could cause any, or all, of the following potentially hazardous situations:

- Occupants could be thrown forward due to unexpected loss of forward motion, a particular concern for passengers in the front of the boat who could be ejected over the bow and possibly struck by the gear case or propeller.
- Loss of power and directional control in heavy seas, strong current, or high winds.
- Loss of control when docking.

Boat Harness

DRAWING

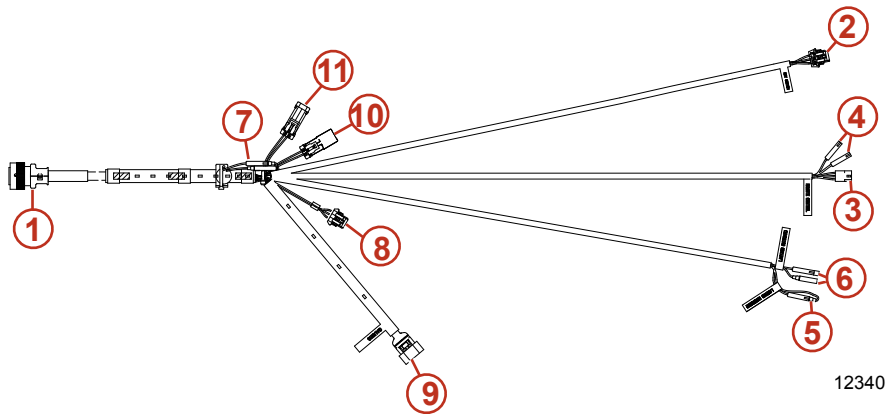

- 1** - 14-pin Deutsch connector
- 2** - Key switch connector
- 3** - Trim switch (outboard only)
- 4** - Neutral switch
- 5** - Lanyard switch (sterndrive) or key switch + connection
- 6** - Lanyard (outboard) or E Stop connection
- 7** - Warning horn
- 8** - Accessory relay connection (15-amp)
- 9** - Gauge connector/CAN connector for SmartCraft
- 10** - CAN P (1) with resistor cap
- 11** - CAN V (3) with weather cap

DIAGRAM

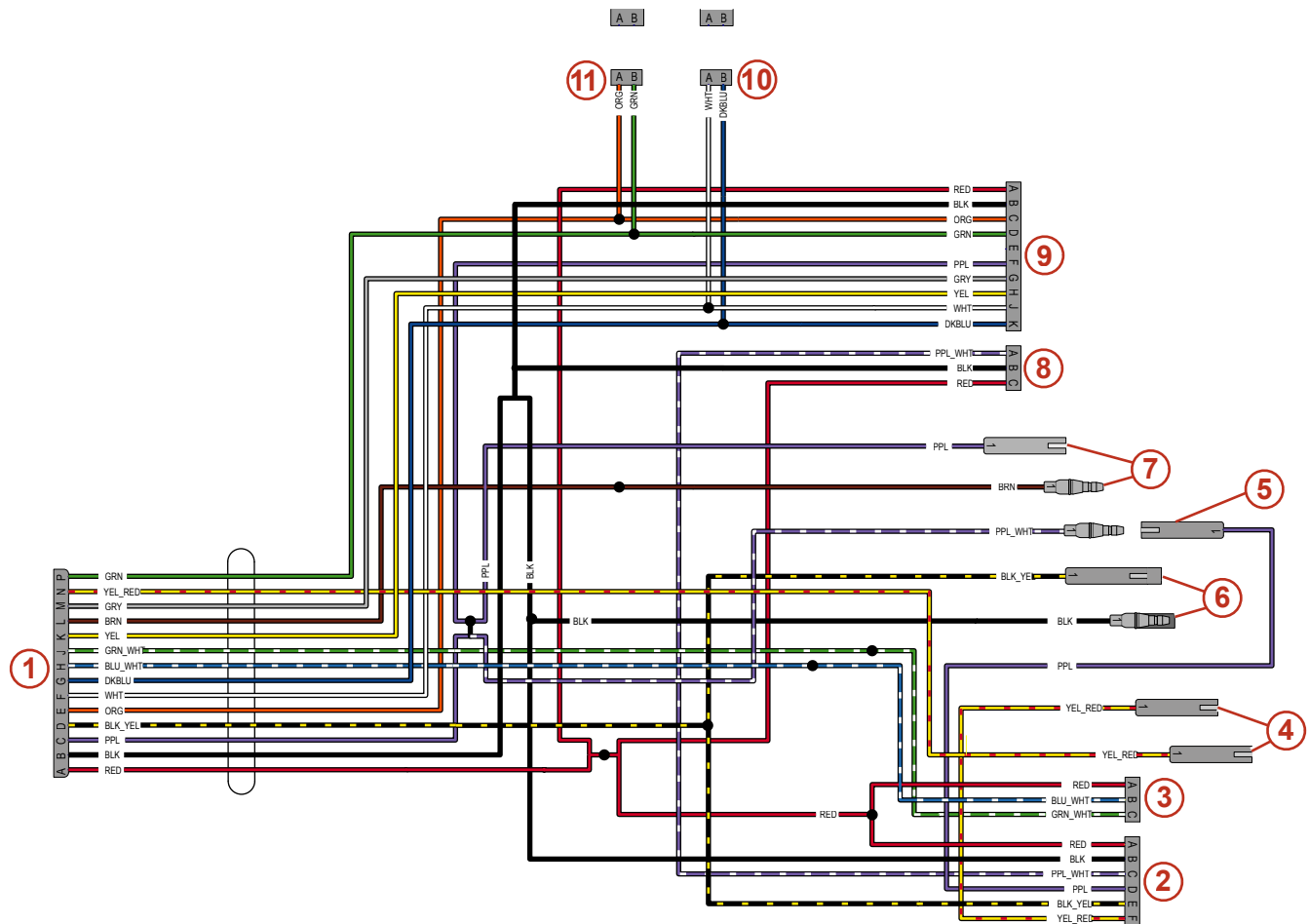

12339

- | | |
|--|---|
| 1 - 14-pin Deutsch connector | 7 - Warning horn |
| 2 - Key switch connector | 8 - Accessory relay connection (15-amp) |
| 3 - Trim switch (outboard only) | 9 - Gauge connector |
| 4 - Neutral switch | 10 - CAN P (1) with resistor cap |
| 5 - Lanyard switch (sterndrive) or key switch + connection | 11 - CAN V (3) with weather cap |
| 6 - Lanyard (outboard) or E Stop connection | |

NOTE: Dual engines are treated as 2 singles in the same boat and are only connected by a CAN 1 link harness.

NOTE: The lanyard stop switch (PPL and PPL/WHT wires) breaks power to the ECM or ignition to stop the engine. The switch is normally **closed** until activated. Therefore the PPL and PPL/WHT wires must be connected together if Lanyard Stop Switch is not used, or if the E Stop Switch is used.

NOTE: E Stop Switch (BLK and BLK/YEL wires) connects ground to ECM to stop engine. The switch is normally **open**, the circuit closes when switch is activated. Wires must be separate unless connected through E Stop Switch.

Instrumentation Harness Receptacle

IMPORTANT: Loose or corroded harness connectors are a common source for engine malfunctions.

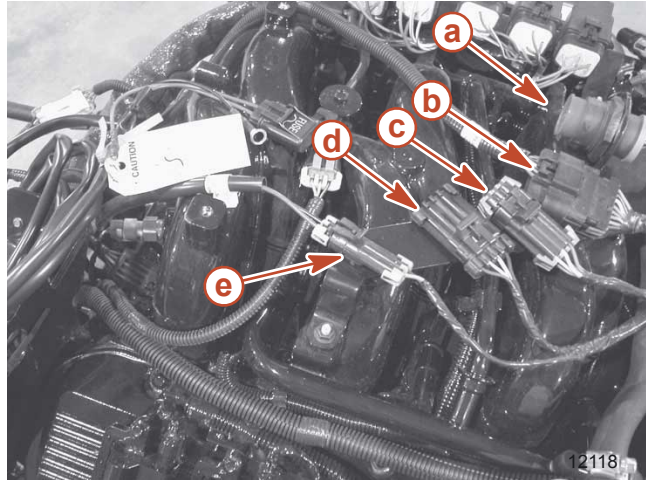

Typical 14-pin DTS harness without Emissions Control

- | | |
|--|---|
| a - Engine harness connector | d - DLC/depth transducer connector |
| b - Transmission harness connector | e - Power harness connector/clean power with 5-amp fuse (DTS and PCM09 only) |
| c - Paddle wheel/tank level connector | |

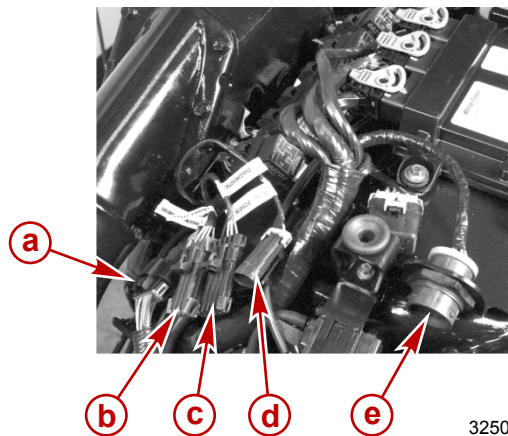

- | | |
|--|-------------------------------------|
| a - Transom harness connector | d - Power harness connector |
| b - Paddle wheel and tank level connector | e - 14-pin harness connector |
| c - Diagnostic connector | |

14-Pin Engine—Analog Gauge Harness

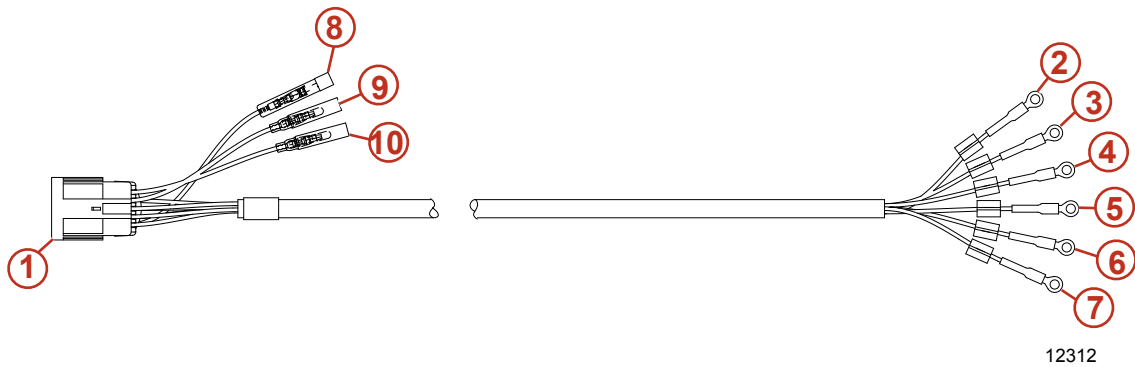

12312

- | | |
|--------------------------------------|-----------------------------|
| 1 - Connector to boat harness | 6 - Oil |
| 2 - Trim | 7 - Ground (-) |
| 3 - Tach | 8 - Can (+) or spare |
| 4 - Key on (+) | 9 - Can (-) or spare |
| 5 - Temp | 10 - 12V (+) |

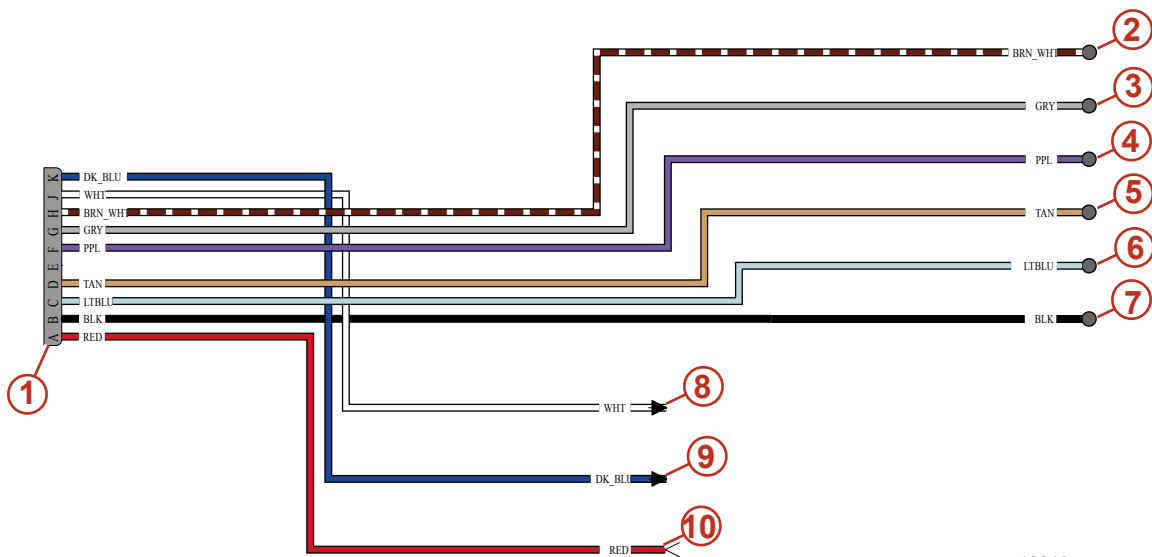

12318

- | | |
|--------------------------------------|-----------------------------|
| 1 - Connector to boat harness | 6 - Oil |
| 2 - Trim | 7 - Ground (-) |
| 3 - Tach | 8 - Can (+) or spare |
| 4 - Key on (+) | 9 - Can (-) or spare |
| 5 - Temp | 10 - 12V (+) |

Accessory power can be provided up to 15 amps total; on purple wire (switched) and red wire (continuous power.)

An accessory relay kit can be used for loads up to 40 amps. Refer to MerCruiser Parts and Accessory Guide or MerCruiser Rigging Guide

14-Pin Engine Harness Connector

Mechanical 14-Pin Connector Pin-Out		
Pin	Wire Color	Function
A	PINK	+ 12 Volt
B	BLACK	Ground (-)
C	PURPLE	Wake
D	DK GREEN/YELLOW	E-Stop
E	DK BLUE	Analog oil pressure
F	WHITE	CAN 1+
G	LT BLUE	CAN 1-
H	Open	Spare
J	Open	Spare
K	ORANGE/WHITE	Analog trim position
L	BROWN/DK BLUE	Audio warning horn
M	GRAY/WHITE	Tachometer/Link gauge
N	YELLOW/BLACK	Crank
P	TAN	Analog coolant temperature

Remote Control and Cables

Requirements and Recommendations

We recommend using Quicksilver remote controls, which have been specifically designed for compatibility with our engines, and to the same high quality and performance standards. An extensive array of Quicksilver remote controls and cables are available through the **Mercury Precision Parts Accessories Guide**.

A single lever control (shift and throttle function in same lever) or a two-lever control (separate shift and throttle levers) can be used on single station applications. Two-lever controls are required on dual station (helm) applications.

- Remote control must provide a cable travel (at engine end).

Remote Control Cable Travel	
Function	Travel [with 6.8-9 kg (15-20 lb.) load applied]
Shift	70– 80 mm (2-3/4–3-1/8 in.)
Throttle	70–80 mm (2-3/4–3-1/8 in.)

- The remote control must be set up to retract the shift cable when going into FORWARD gear on Velvet Drive 71C and 72C in-line transmissions. On Velvet Drive 5000 and all Hurth transmissions, shift cable actuation must be set up to achieve the desired propeller rotation. See information in **Section 2 - Transmission and Drive Line**.

NOTICE

Incorrect positioning of the transmission shift lever can cause transmission failure. The spring-loaded poppet ball helps the transmission shift lever to stay in place. Do not remove the poppet ball or spring.

- The remote control must be set up to fully extend the throttle cable for idle.
- A neutral start safety switch is included in the transmission. The switch in the remote control should not be used.

Installation

Install the remote and cables in accordance with the instructions which accompany them and the instructions in the power package installation manual. To ensure minimal shift and throttle effort, be sure to observe the following important information:

- Do not fasten the cables to the boat or any other objects within 92 cm (3 ft.) of the remote control and engine attaching points.
- Keep bends to a minimum.
- Route cables so that they do not have less than an 20 cm (8 in.) radius at all bends.
- Ensure that the cables are not kinked or pinched.
- Lubricate the cable guides and pivot points with 2-4-C Marine Lubricant or motor oil.

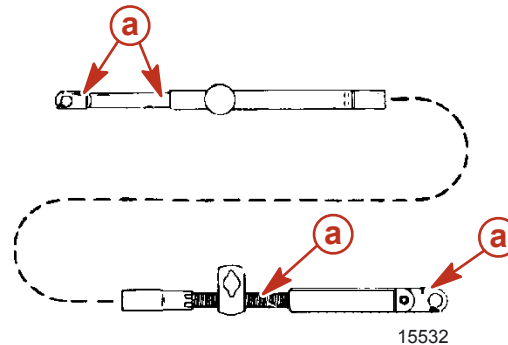

a - Points to lubricate

Tube Ref No.	Description	Where Used	Part No.
 95	2-4-C with Teflon	Cable guides and pivot points	92-802859A 1

- Tighten cable attaching nuts until they contact, then loosen 1/2 turn (until the washer under the nut can be turned with your fingers). The attaching points must be free to pivot.

Dual Station (Helm) Cable Setup

The remote control cables can be connected in series or parallel. When connected in series, the remote control cables from the secondary station are connected to the remote control at the primary station. The primary station cables are then connected to the engine, using the single cable attachment procedure. On some applications, it may be preferable to connect both sets of cable directly to the engine, using a parallel connection. Mercury MerCruiser inboard engines come equipped with the necessary hardware for making either type of connection.

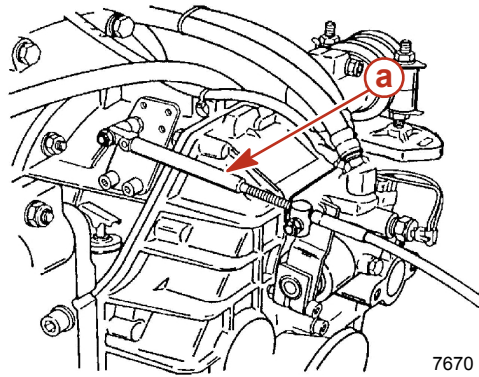

7670

Typical series cable installation

a - Shift cable

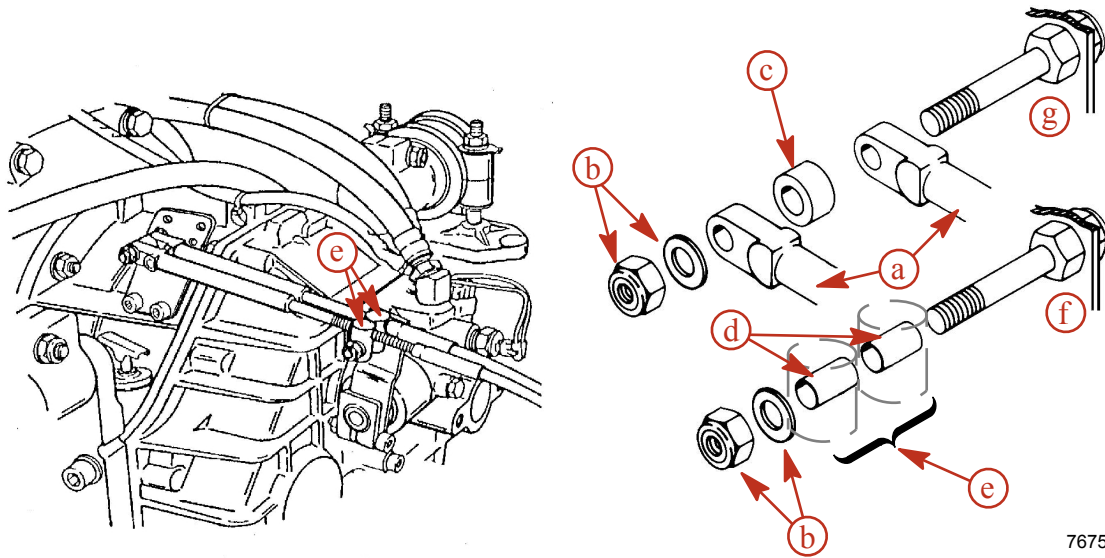

7675

Typical parallel cable installation

a - Cable end guide
b - Locknut and washer
c - Spacer (fits over bushings)
d - Bushing

e - Cable barrel location
f - Cable barrel stud
g - Cable end guide stud

Cable Attachment Hardware

INBOARD MODELS

Inboard models can accommodate forward or aft shift cable entry and single or dual cable attachment. Hardware must be installed as shown.

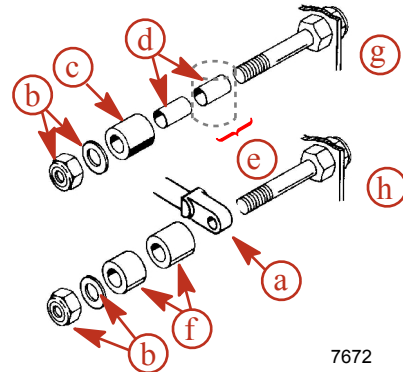
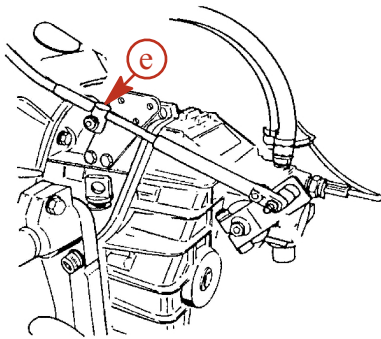

7672

Typical single cable: forward entry

- | | |
|--|------------------------------------|
| a - Cable end guide | e - Cable barrel location |
| b - Locknut and washer | f - Spacer (fits over stud) |
| c - Spacer (fits over bushings) | g - Cable barrel stud |
| d - Bushings | h - Cable end guide stud |

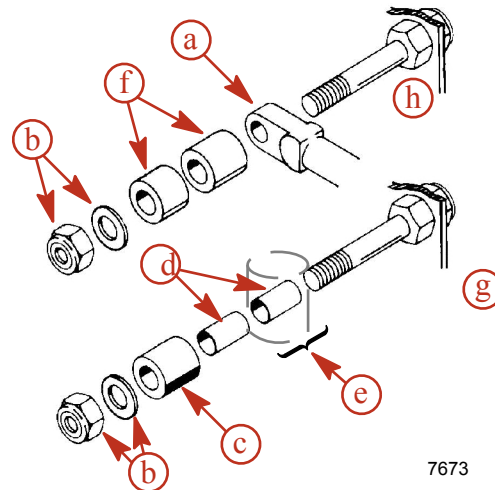
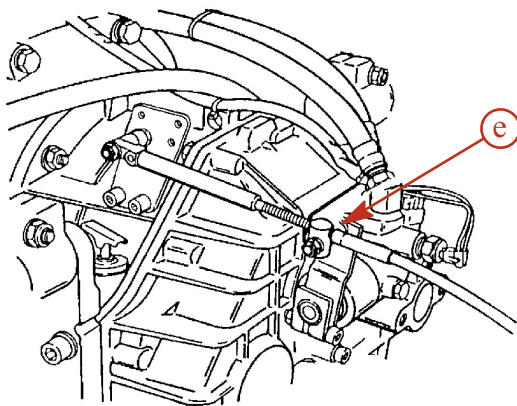

7673

Typical single cable: rear entry

- | | |
|--|-------------------------------------|
| a - Cable end guide | e - Cable barrel location |
| b - Locknut and washer | f - Spacers (fits over stud) |
| c - Spacer (fits over bushings) | g - Cable barrel stud |
| d - Bushings | h - Cable end guide stud |

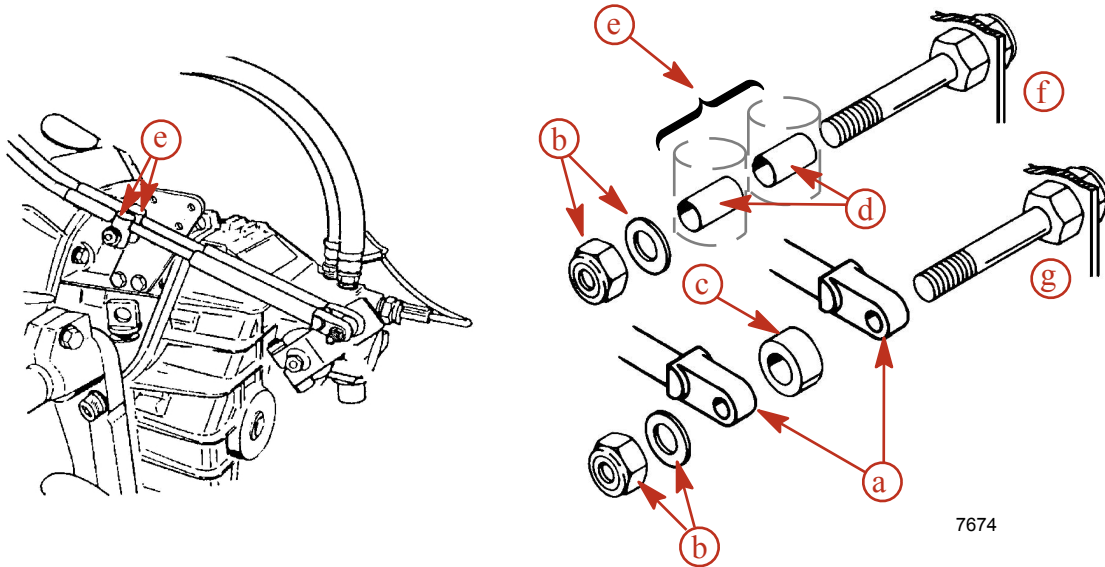

7674

Typical dual cable: forward entry

- | | |
|------------------------------------|-----------------------------------|
| a - Cable end guides | e - Cable barrel locations |
| b - Locknut and washer | f - Cable barrel stud |
| c - Spacer (fits over stud) | g - Cable end guide stud |
| d - Bushings | |

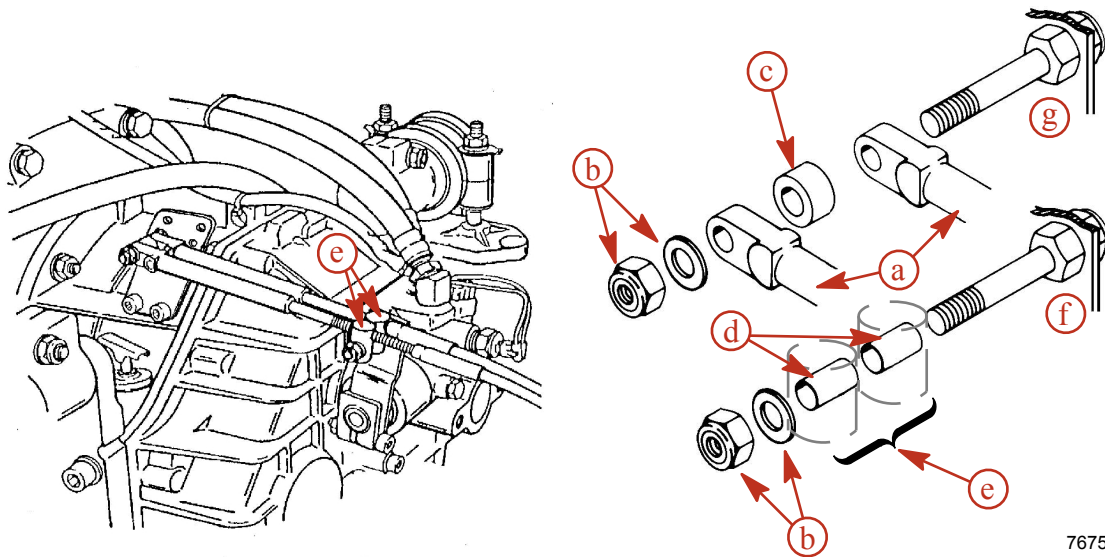

7675

Typical dual cable: rear entry

- | | |
|------------------------------------|-----------------------------------|
| a - Cable end guides | e - Cable barrel locations |
| b - Locknut and washer | f - Cable barrel stud |
| c - Spacer (fits over stud) | g - Cable end guide stud |
| d - Bushings | |

TOW SPORTS MODELS

Tow sports models accommodate single cable forward entry only. Attaching hardware is provided for a Morse cable.

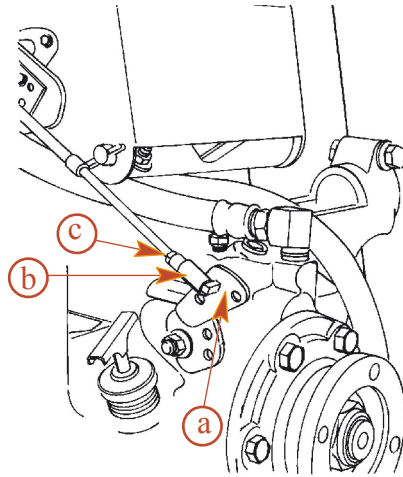

15535

a - Throttle lever stud
b - Cable end

c - Locknut

Cable Adjustment

NOTICE

Incorrect positioning of the transmission shift lever can cause transmission failure. The spring-loaded poppet ball helps the transmission shift lever to stay in place. Do not remove the poppet ball or spring.

The shift and throttle cable must be installed and adjusted exactly as stated in the installation instructions to achieve proper operation and avoid transmission problems. The following items are of particular importance.

- The throttle cable must be adjusted to fully close the engine throttle plates when the remote control is in the neutral, idle position. Failure to do this will result in a high idle, erratic idle, or both.
- Transmission shift lever must be positioned fully in the FORWARD, NEUTRAL and REVERSE selector positions (see **Section 2 -- Propeller Rotation**).

- On Velvet Drive models, the shift lever must be in the designated detent position for each gear.

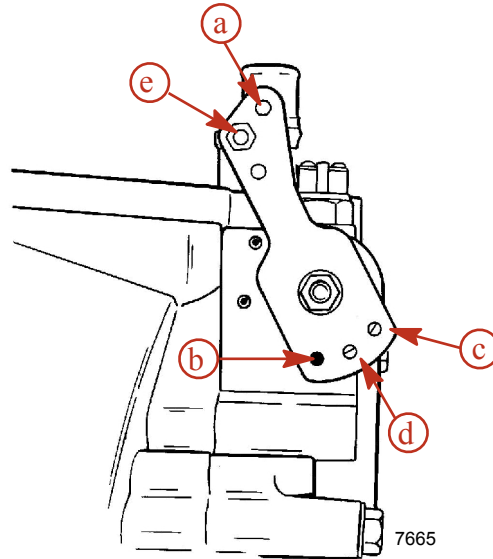

Velvet Drive 5000 series (8 degree down angle shown, V-drive similar)

- a** - Transmission shift lever
 - b** - Poppet ball must be centered in this detent hole when left-hand propeller shaft rotation is desired
 - c** - Poppet ball must be centered in this detent hole when right-hand propeller shaft rotation is desired
 - d** - Poppet ball must be centered in this detent hole for neutral position
 - e** - Install shift lever stud in this hole when using quicksilver shift cables
- On ZF Marine (Hurth) transmissions, the shift lever must be against the stops for forward and reverse, and in the centered detent position for neutral.

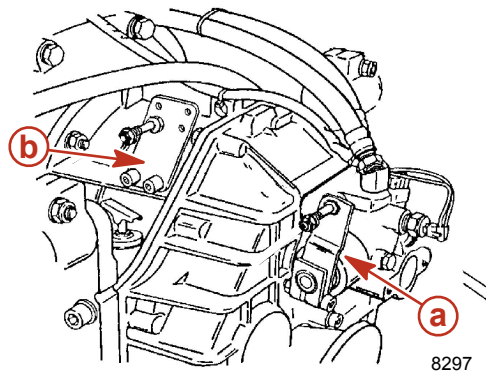

Typical ZF Marine (Hurth) transmission shown

- a** - Shift lever
- b** - Shift cable bracket

- Velvet Drive In-line 71C and 72C transmissions must be operated with the shift lever in the FORWARD gear selector position when propelling the boat forward. Damage to transmission will result if it is operated in REVERSE (with the wrong rotation propeller) under full power.

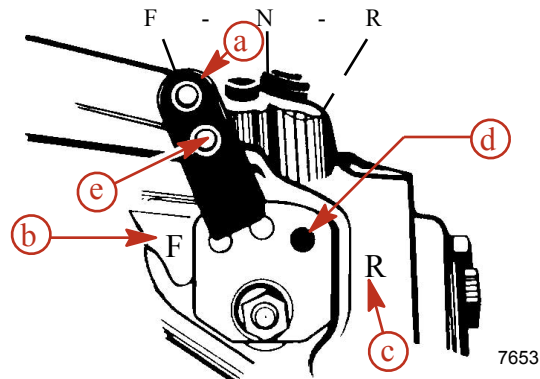

Velvet Drive 71C and 72C Transmission

- a** - Transmission shift lever
- b** - Shift lever must be over this letter when propelling boat FORWARD
- c** - Shift lever must be over this letter when propelling boat in REVERSE
- d** - Poppet ball must be centered in detent hole for each F-N-R position (FORWARD gear shown)
- e** - Install shift lever stud in this hole, to center poppet ball in FORWARD and REVERSE detent holes

Motoviewer

MotoViewer Service Tool

At this time, the Computer Diagnostic System (CDS) software does not communicate with products using the PCM 09 controller through the RS-485 connection. However, all engine and vessel set up, information, and fault codes are available using a new software package from MotoTron called MotoViewer. All communications to MotoViewer travel over the existing RS-485 connection using the CDS laptop and SmartComms. You must install a special SmartComms software update (CDS 8.2x) to the CDS laptop to use MotoTron software. Contact your Product Integration Engineer (PIE) or Technical Account Manager (TAM) for assistance.

To connect MotoViewer to an engine using PCM 09, obtain the following:

Description	Part Number
SmartComms Interface Box	System contact: SPX Corporation 28635 Mound Rd. Warren, MI 48092 or call: USA - 1-800-345-2233 Canada - 800-345-2233 Europe - 49 6182 959 149 Australia - (03) 9544-6222
Diagnostic Tester Harness Assembly for PCM 555 models	84-822560A13

NOTE: If the Diagnostic Tester Harness Assembly (84-822560A13) is unavailable, you can order harness 84-822560T12 and adapter 84-822560A5.

Saving Special Functions

IMPORTANT: You must cycle the key switch after performing some special functions to store the calibration values in the propulsion control module (PCM). If you are saving a special function on a DTS engine, you must also place the remote control in reverse, wide open throttle (RWOT).

Access special functions from the **Special** menu.

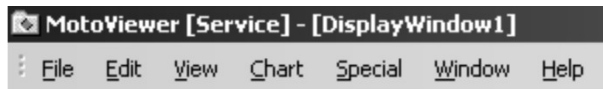

35003

Special functions that require a key cycle include:

- Set Engine Location
- Turn AutoSync Off
- Alter Trim Limit
- Alter Trailer Limit
- Configure Easy-Link Gauges

To save a special function calibration to the PCM:

1. Perform the special function as described in this manual and the on-screen prompts.
2. Turn the key switch to "OFF" to retain settings.
3. If the engine is equipped with DTS, turn the key switch to "OFF" and place the remote control handle in reverse, wide-open throttle (RWOT) to retain settings.

NOTE: The Cylinder Misfire, Output Device Control, Start, and Emergency Stop! features are disabled.

Clearing Fault History

1. From the Special menu, select **Clear Fault History**.

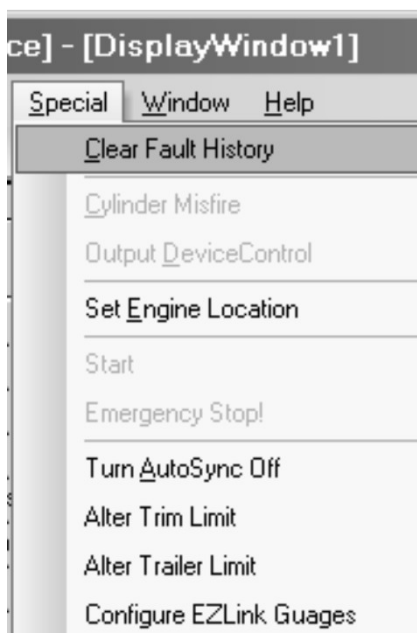

35006

2. Click **OK** to clear the fault history or **Cancel** to abort.

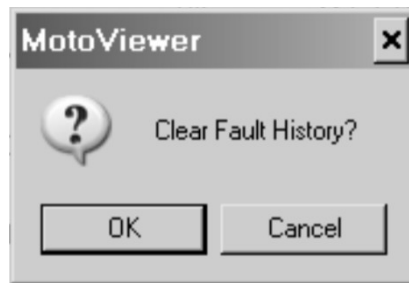

35007

Setting Engine Location

1. Turn the key switch to the "ON" position.
2. From the Special menu, select **Set Engine Location**.

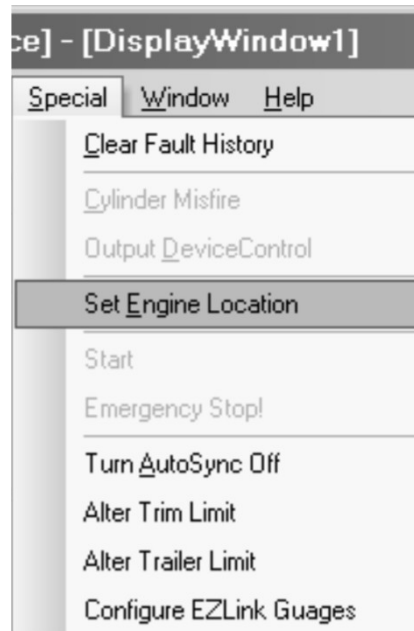

35008

3. From the Transom Configuration drop-down list, choose the configuration that matches the vessel: **Single**, **Twin**, **Triple**, or **Quad**.

4. Select the option that matches the engine location and click **OK** to save or **Cancel** to abort. The default values of each selection are shown below.

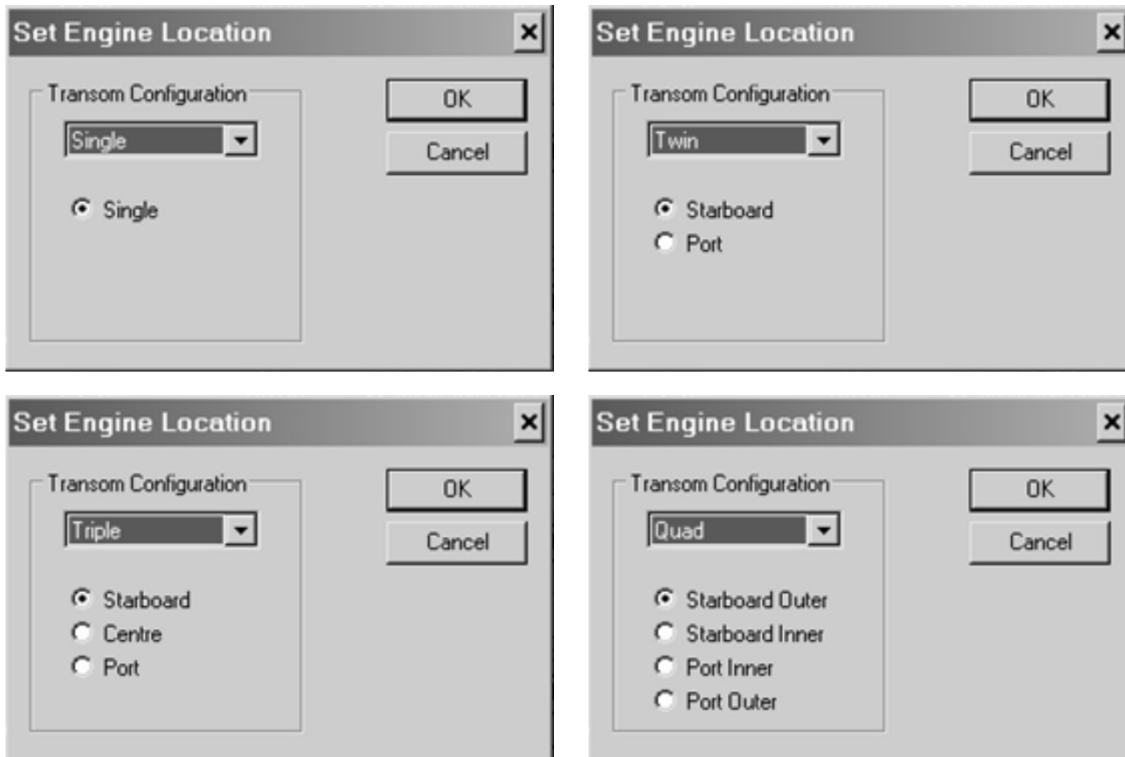

35009

5. Turn the key switch to "OFF" to retain settings.
6. If the engine is equipped with DTS, turn the key switch to "OFF" and place the remote control handle in reverse, wide-open throttle (RWOT) to retain settings.

AutoSync

The AutoSync feature synchronizes RPM for engines in a multiple-engine application. When engine speed exceeds 900 RPM, or when the two ERC handles are within 5° (10%) of each other, AutoSync engages for two seconds. In a multiple-engine application, the starboard engine is the master engine. The other engines then match the master engine RPM. Use MotoViewer to disable or enable AutoSync.

1. Turn the key switch to the "ON" position.

- From the Special menu, select **Turn AutoSync Off**.

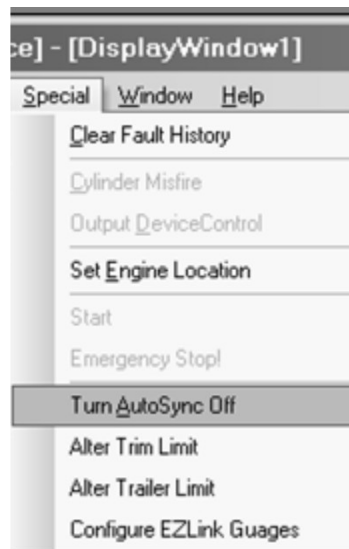

35010

- Click **OK** to turn off AutoSync or **Cancel** to abort.

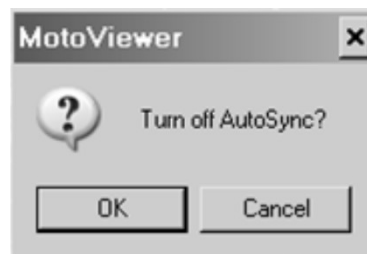

35011

- Turn the key switch to "OFF" to retain settings.
- If the engine is equipped with DTS, turn the key switch to "OFF" and place the remote control handle in reverse, wide-open throttle (RWOT) to retain settings.

Trim and Trailer Limit

ALTER TRAILER LIMIT

- Turn the key switch to the "ON" position.
- From the Special menu, select **Alter Trailer Limit**.



35012

3. Trim the drive down using the electronic remote control (ERC) until the drive reaches its full, down position and squeaks for 3 seconds. The PCM records this as the full, down position.
4. Trailer the drive up using the ERC or other switch to the highest position possible without contacting the vessel or damaging components. The PCM records this location as the upper trailer limit (100%).
5. Trim the drive to any desired position.
6. From the Limit DFM window's drop-down menu, select **Current Position**.

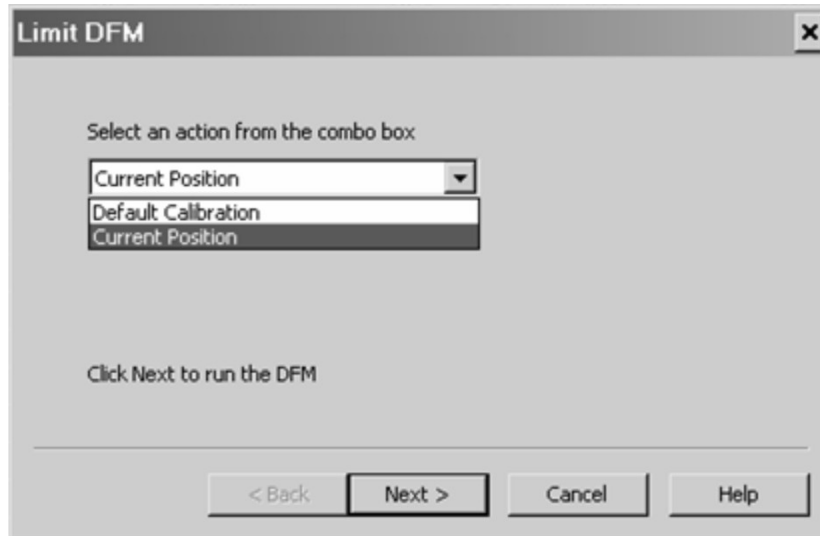

35013

7. Click **Next** to continue or **Cancel** to abort.
8. Turn the key switch to "OFF" to retain settings.
9. If the engine is equipped with DTS, turn the key switch to "OFF" and place the remote control handle in reverse, wide-open throttle (RWOT) to retain settings.
10. Click **Finish** to save the calibration settings or **Cancel** to abort.

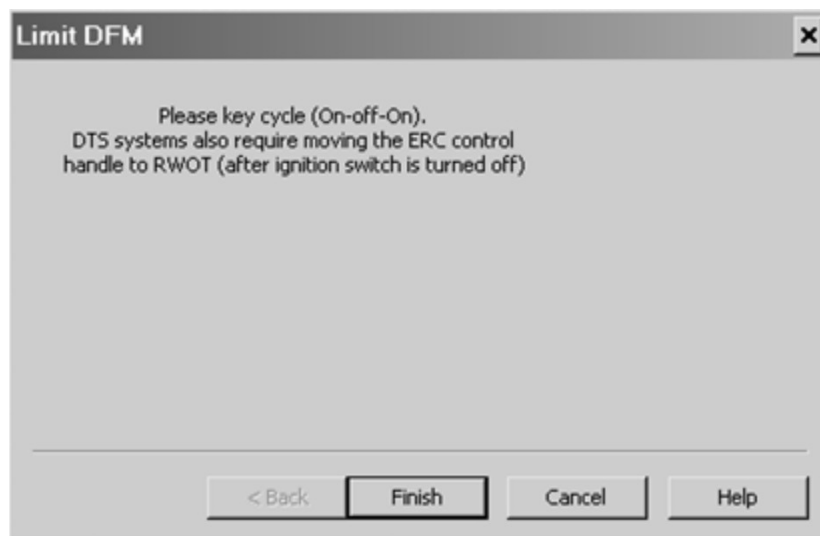

35014

11. Set the trim limit as detailed below.

ALTER TRIM LIMIT

IMPORTANT: Always set the trailer limit before setting the trim limit.

1. Turn the key switch to the "ON" position.

- From the Special menu, select **Alter Trim Limit**.

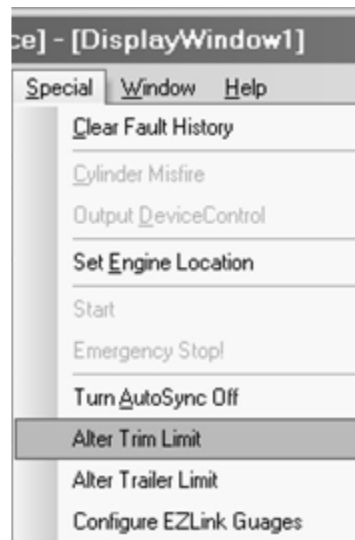

35097

- Trim the drive down using the electronic remote control (ERC), until the drive reaches its full, down position and squeaks for 3 seconds. The PCM records this as the full, down position.
- Trim the drive up using the ERC or other switch to the desired position for the trim limit while monitoring the trim position counts on MotoViewer. The PCM records this location as the upper trim limit.

a	37	Trim Sensor	0.0	%	135	Counts
----------	----	-------------	-----	---	-----	--------

b

35091

a - Trim sensor data**b** - Trim position counts

IMPORTANT: Trim position counts must not exceed 180 counts past the original trim in position. If you exceed this, it will fail the trim setting. You will have to start over. For example, if your original trim in position count is 135, you cannot exceed 315 counts, or the trailer setting will not calibrate correctly ($135 + 180 = 315$).

5. Measure from anchor pin centers. The distance between both front and rear pins must not exceed 55.25 cm (21.75 in.).

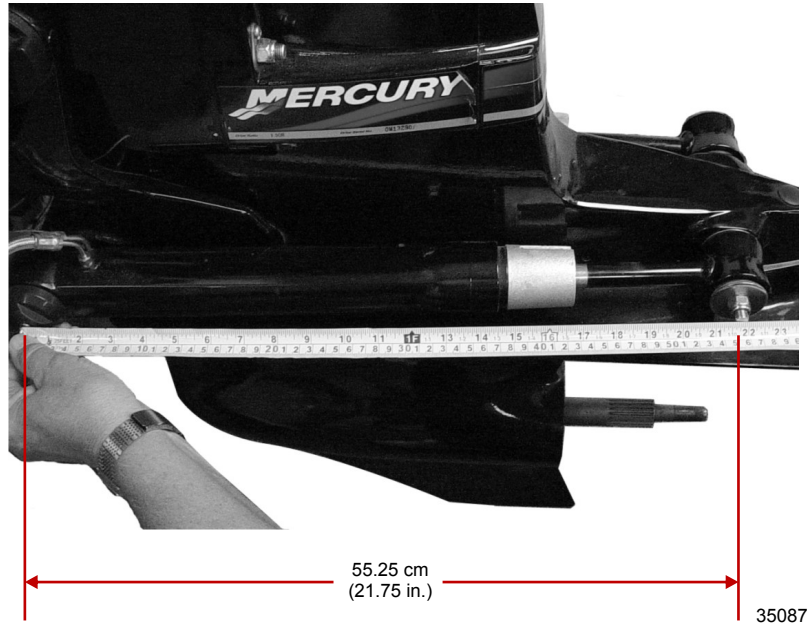

6. Trim the drive to any desired position.
7. From the Limit DFM window's drop-down menu, select **Current Position**.
8. Click **Next** to continue or **Cancel** to abort.

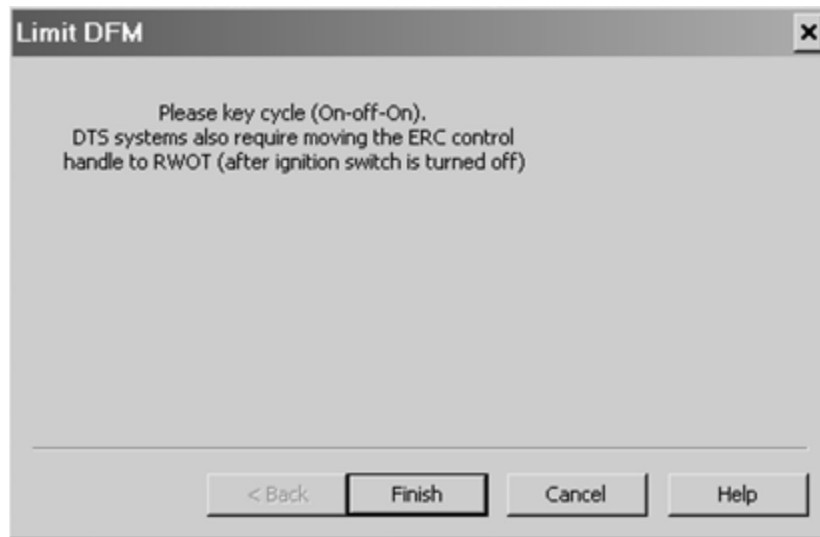

9. Turn the key switch to "OFF" to retain settings.
10. If the engine is equipped with DTS, turn the key switch to "OFF" and place the remote control handle in reverse, wide-open throttle (RWOT) to retain settings.
11. Click **Finish** to save the calibration settings or **Cancel** to abort.

RESET TRAILER LIMIT

If you cannot reach your desired trailer limit, you may need to reset the system. To reset the trailer limit after the PCM has accepted a limit calibration:

1. Turn the key switch to the "ON" position.

- From the Special menu, select **Alter Trailer Limit**.



35012

- Trim the drive down using the ERC until the drive reaches its full, down position and squeaks for 3 seconds. The PCM records this as the full, down position.
- Using a remote switch on the trim pump, trailer the drive to the highest trailer position desired.
- From the helm (ERC) trim switch, press the trim up button for 3 seconds. The trim pump will not operate at this time. The PCM records this location as the upper trailer limit (100%).
- Turn the key switch to "OFF" to retain settings.
- If the engine is equipped with DTS, turn the key switch to "OFF" and place the remote control handle in reverse, wide-open throttle (RWOT) to retain settings.

Configuring EZLink Gauges (TachLink)

- Turn the key switch to the "ON" position.
- From the Special menu, select **Configuring EZLink Gauges**.

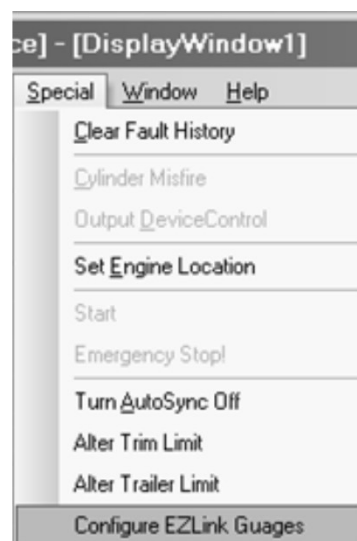

35028

- In the pop-up window, choose:

- **Yes** to enable easy-link to change the tachometer signal to a communication signal and turn on an AGI or run SC100 gauges without an SC1000 series or VesselView display.
- **No** to enable easy-link to return the tachometer output lead to its normal tachometer signal.
- **Cancel** to abort.

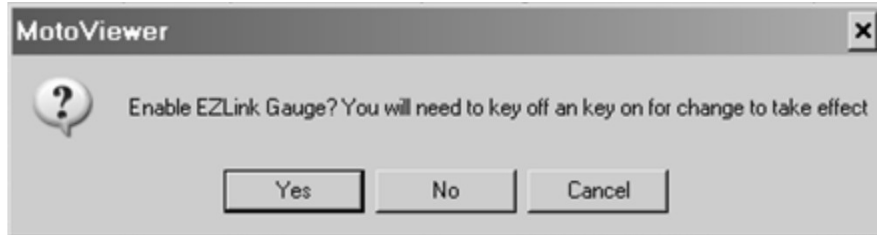

35029

4. Turn the key switch to "OFF" to retain settings.
5. If the engine is equipped with DTS, turn the key switch to "OFF" and place the remote control handle in reverse, wide-open throttle (RWOT) to retain settings.

Other Special Functions

The Cylinder Misfire Test, Output Device Control, Starting, and Emergency Stop features are currently disabled for products equipped with PCM09.