

*1: M/T *3: no ABS
 *2: A/T *4: with ABS

Engine control (2L-TE)

*1: MT *3: no ABS
*2: AT *4: with ABS

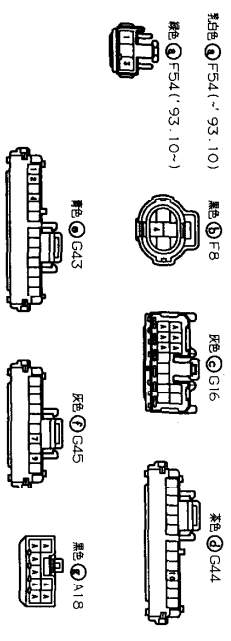
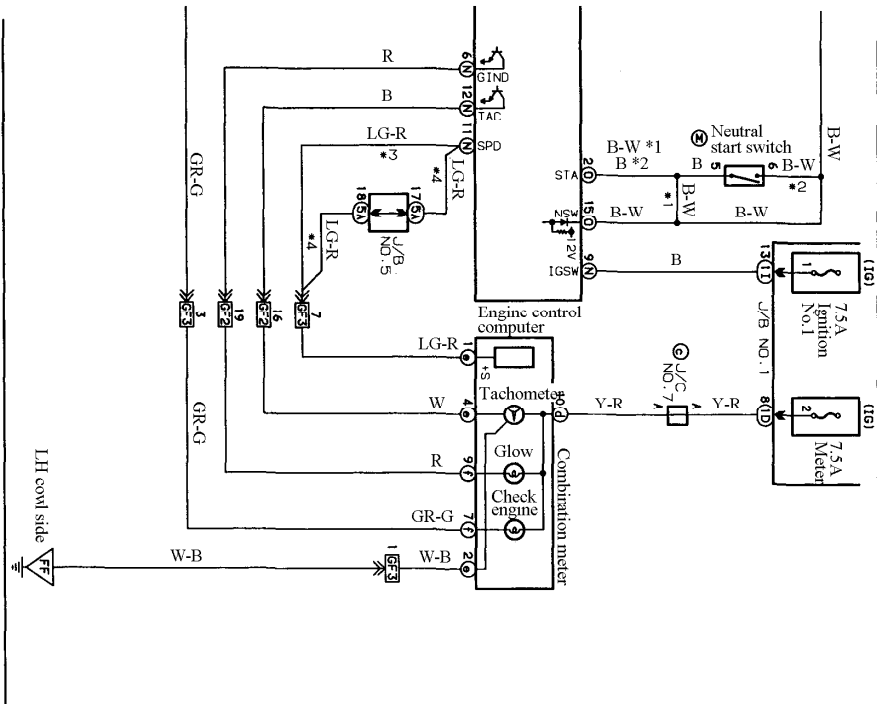

2L-TE Engine Control Unit – May 21, 2005

| | | | | | | | | | | | | | | | | | | |
|-----------------|-----|-----|-----|-----|-----|------|-----|-----|-----|----------------|----------------|-----|-------|-------|-------|------|----|-----|
| E ₀₁ | TCV | SPV | STA | NSW | NE+ | TDC+ | VC | PIM | VRP | THW | EGR | SPD | | | BAT | | | |
| E ₀₂ | | | | | NE- | TDC- | THA | VA | VRT | E ₂ | E ₂ | IDL | M-REL | S/TH1 | S/TH2 | IGWS | +B | +BF |

2L-TE A/T Electronically Controlled Transmission – May 21, 2005

| | | | | | | | | | | | | | | | | | | |
|-----------------|----|----|-----|-----|-----|------|-----|-----|-----|----------------|----------------|-----|-------|-------|-------|------|----|-----|
| S1 | S2 | S3 | STA | NSW | NE+ | TDC+ | VC | PIM | VRP | THW | EGR | SPD | | | | | | |
| E ₀₂ | | | | | NE- | TDC- | THA | VA | VRT | E ₂ | E ₂ | IDL | M-REL | S/TH1 | S/TH2 | IGWS | +B | +BF |