

The GRT4 VME Pulse Processing Card for Segmented Germanium Detectors

I.H.Lazarus, D.E.Appelbe, A.J.Boston, P.J.Coleman-Smith, J.R.Cresswell, M.Descovich, S.A.A.Gros, M.Lauer, J.Norman, C.J.Pearson, V.F.E.Pucknell, J.A.Sampson, G.Turk, J.J.Valiente-Dobon

Abstract-- A four channel VME card with 14 bit, 80 MHz digitizers and powerful on-board processing has been designed, built and used in tests of digital pulse processing techniques for gamma-ray tracking. This paper explains the background (rationale for the project), describes the VME card (known as the GRT4) and presents a 64 channel GRT4 digitizing system which was used to instrument two segmented Germanium detectors during in-beam tests. Results obtained using the GRT4 card are presented as well as some applications.

I. INTRODUCTION

ARRAYS of Germanium (Ge) detectors have been used to detect gamma rays in Nuclear Physics experiments for many years (TESSA, NORDBALL, EUROGAM, EUROBALL, GAMMASPHERE and others) [1]. Conventionally the Ge detectors have been enclosed in Bismuth Germanate (BGO) escape suppression shields. The BGO shields are used to reject those gamma rays which deposit only part of their energy in the Ge before scattering out of the detector. The percentage of gamma rays which scatter out is energy dependent, but typically only 20% deposit their full energy in a single Ge detector. Clearly there is scope for improvement.

The next generation of gamma-ray arrays (AGATA [2] and GRETA [3]) will not use escape suppression. Instead the arrays will be made entirely of Ge detectors. They will employ

a technique called gamma-ray tracking [4] to trace the scattering gamma rays within the array, adding up the energy deposited at each of the points on the track to determine the energy of the incident gamma ray. This reconstruction is possible because the energy and direction of the scattering gamma rays are related by the Compton scattering formula. In order to determine scattering direction, it is necessary to know the position of each interaction. The better the positional information, the less ambiguity in the tracking. Part of this positional information comes from segmenting the outer contacts of the Ge detectors. The first steps in this direction have already been made by the Miniball [5] and EXOGAM [6] arrays which use Ge detectors segmented longitudinally, primarily to improve Doppler correction. Finer segmentation is required for Ge tracking detectors, and so the longitudinal segmentation must be further divided into rings of segments resulting in typically 24 or 36 segments.

Such segmentation by itself still doesn't provide sufficiently fine position determination, so it is necessary to subdivide the segments by analysing the shapes of the charge pulses collected from them to obtain more exact positional information.

In addition to the good positional information, good energy resolution is needed too since uncertainty in either parameter compromises the tracking performance. Moreover, the individual interaction energies will be summed to give the reconstructed gamma-ray energy so the noise from each interaction's energy measurement should be minimized for this reason too. Similarly low energy thresholds are necessary so that no interactions are missed from the reconstruction process.

This paper describes a VME card which has been used to investigate the pulse processing required in gamma-ray tracking arrays. It digitises and processes charge pulses from segmented Ge detectors so as to determine interaction position as well as energy deposited and the time it arrived.

II. THE GRT4 VME CARD

The GRT4 card (Gamma-Ray Tracking 4 channel) was designed for the UK Gamma-Ray Tracking and Digital Pulse Processing project (a joint research project between CCLRC

Manuscript received October 16th 2003. This work was supported by the UK Engineering and Physical Science Council (EPSRC) under Grant Nos. GR/M49489/01, GR/M49595/01 and GR/M49625/01.

I. H. Lazarus is with CCLRC, Daresbury Laboratory, Warrington WA4 4AD, UK (telephone: +44 1925 603433, e-mail: I.H.Lazarus@dl.ac.uk).

D. E. Appelbe, P. J. Coleman-Smith, V. F. E. Pucknell are all with CCLRC, Daresbury Laboratory, Warrington WA4 4AD, UK

A.J.Boston, J. R. Cresswell, S.Gros, J. Norman, J. Sampson and G.Turk are all with Oliver Lodge Laboratory, University of Liverpool, P.O. Box 147 Liverpool L69 7ZE, UK

M.Descovich was with Oliver Lodge Laboratory, University of Liverpool, P.O. Box 147 Liverpool L69 7ZE, UK. She is now with Nuclear Science Division, Lawrence Berkeley National Laboratory, 1 Cyclotron Road, MS 88R0192, Berkeley, CA 94720 USA

C.J.Pearson and J.J.Valiente-Dobon are both with Department of Physics, University of Surrey, Guildford, GU2 7XH, UK

M.Lauer is with Max-Planck-Institut für Kernphysik, Postfach 10 39 80, 69029 Heidelberg, Germany

Daresbury Laboratory, University of Liverpool and University of Surrey). A hardware implementation of the Moving Window Deconvolution (MWD) energy determination algorithm [7], [8] was done in collaboration with MPI-K Heidelberg.

The project bought two segmented detectors; one with 6x6 segmentation from Eurisy Measures and one with 6x4 segmentation, from Ortec. The aim was to develop the techniques necessary to do gamma-ray tracking. The GRT4 digitizing and processing card was designed in order to instrument these detectors for characterization scanning and for in-beam tests. It was necessary to design the GRT4 cards ourselves because there were no commercial products available with the required combination of sampling speed (80MHz), resolution (14 bits) and on-board processing.

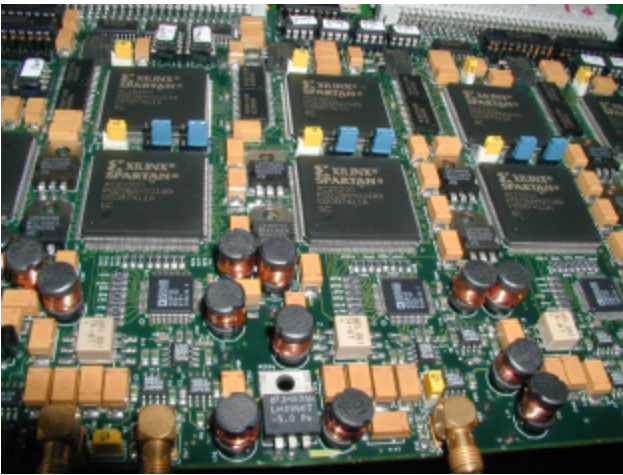

Fig. 1. Photograph of the GRT4 VME card

The GRT4 card (shown in figures 1 and 2) includes four acquisition channels operating in parallel. Each channel has a 14 bit 80MHz flash ADC (AD6645). The analogue inputs are filtered with a 40MHz low pass filter and include an optional differentiation stage so that the ADC is presented with either the raw input or a differentiated input representing the detector current pulse.

The processing and data buffering of the ADC output is performed by two dedicated Xilinx Spartan 2 field programmable gate arrays (FPGA) per channel. Each FPGA has 200k gates available. The first contains a circular buffer (512 samples deep) with programmable pretrigger delay, a digital trigger algorithm and an energy determination algorithm. Each trace in this buffer is tagged with a 16 bit header (8 ID bits are programmable, 8 bits are the trigger counter) and a 48 bit timestamp (12.5ns/bit) when the trigger occurs. The second FPGA is used either for trace buffering or for further pulse processing (such as timing or interaction position). Readout takes place over the VME bus using the block transfer protocol.

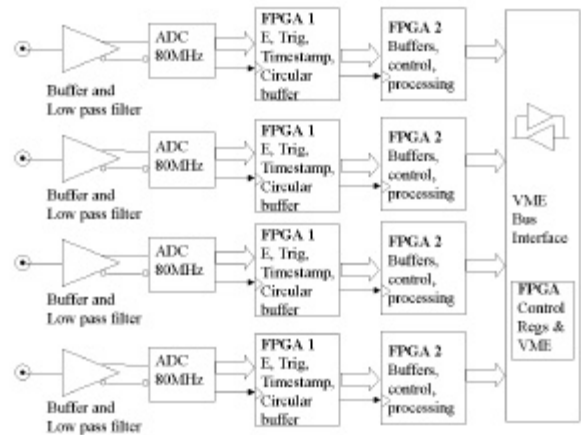

Fig. 2. Block diagram of the GRT4 VME card. This is simplified to show only the main components. Triggering, gating and inter-channel data paths are not shown.

The GRT4 card can work in 2 modes:

- **Oscilloscope mode** where it just digitises and stores the pulses from the Ge detector using 512 sample traces. In this case all the traces are read out to a PC and stored for offline analysis and algorithm development. The traces can be replayed many times to fine-tune algorithms. In this mode the PC is used to perform online analysis to extract energy spectra and show rise time distribution plots in real time so that results can be visualised while data are written to tape.
- **Processing mode** where pulse processing is done on board and a small part of the digitised trace is sent out along with the derived parameter(s). This would normally work by determining the energy from a trace length of about 10us (800 samples) and then passing on the energy and a shorter trace with just the leading edge of the pulse (50 samples, 625ns) for offline pulse shape analysis or analysis in the second FPGA.

In order to synchronise multiple GRT4 cards, an external trigger input is provided. It is also possible (though more complicated) to use internal trigger algorithms since each channel's trigger decision is available to the other 3 channels and, via the trigger output, to other GRT4 cards. Usually the external trigger comes from a Constant Fraction Discriminator (CFD) on the centre (core) contact of the Ge detector (or the logical OR of 2 CFDs when both the 6x6 and 6x4 detectors are used together). The final part of the synchronization is a Busy output which allows any GRT4 card to indicate that its buffers are full and that no more triggers should be generated until they have been read.

A gate input is provided too which allows multiple cards to be gated on or off simultaneously. The gate input can also be used to synchronize all timestamp counters by resetting them to zero simultaneously if the appropriate control bits are enabled by software.

III. IN-BEAM TESTS OF A GRT4 SYSTEM

A 64 channel system (16 GRT4 cards, see fig 3) has been successfully operated in oscilloscope mode during a week-long in-beam test at the University of Cologne's tandem accelerator laboratory.

The GRT4 cards were located in 2 VME crates (to double the aggregate VME readout rate) and read out by fast VME processors. The processors sent data over two fibre optic 100 base T Ethernets into a Linux PC running several pieces of software. The first was a merger designed specifically for this application. The standard MIDAS software [9] was used for control, user interface and the tape server. Online analysis (sorting) was carried out using MTsort, the Liverpool University Sort Package [10].

The GRT4 cards were run in oscilloscope mode so that all traces from all segments were written to tape for every event. This permits the data to be replayed many times from the tapes to test and optimize different algorithms for energy, timing, position determination and zero suppression.

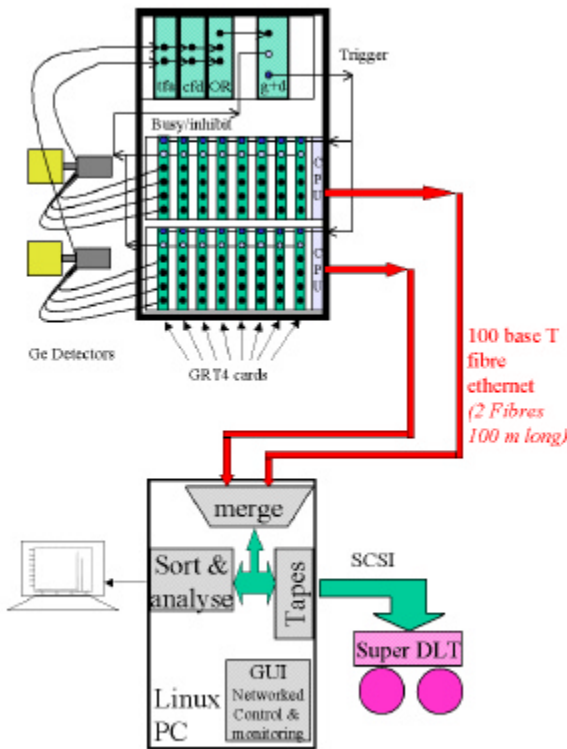

Fig. 3. Diagram of the 64 channel GRT4 system used for the in-beam tests. The rack at the top contains 2 VME crates, each with 8 GRT4 cards and a CPU and also a NIM crate for trigger generation and detector HV supplies.

The data rate to tape was over 7Mbytes/second which equates to a count rate of about 120 events per second. During the run a total of 5 Tbytes of trace data was collected.

The experiment used a 70MeV ^{37}Cl beam which was incident on a deuterated Ti target. The reaction $d(^{37}\text{Cl},n)^{38}\text{Ar}$ was used to populate ^{38}Ar with a recoil velocity of 6% of the speed of light. Severe Doppler broadening of the 2.1 MeV gamma ray in ^{38}Ar was observed and was successfully corrected using pulse shape analysis to determine the position of the first interaction point. These results will be published elsewhere.

Examination of the data traces and lab tests have shown that the analogue input stage up to and including the ADCs is not influenced by the digital buses, the high speed clocks or by cross talk, demonstrating that high resolution analogue and high speed digital electronics can co-exist if the printed circuit board is carefully designed.

IV. DETECTOR SCANNING WITH THE GRT4 CARD AND PULSE SHAPE ANALYSIS

The detector scanning system at the University of Liverpool's physics department was equipped with a GRT4 digitization system comprising up to 64 channels. A collimated radioactive source is moved around the face of the detector using a computer controlled X-Y scanning table. The response of the detector to each source position is measured by recording a set of pulse traces.

This system has been used to scan segmented detectors on their own to characterize their response to collimated gamma-ray sources [11]. It also permits testing of 2 detectors simultaneously. For example, the EXOGAM segmented clover detector (20 channels) and the GREAT planar Ge detector (12 x 24 = 36 channels) have been scanned in a Compton camera configuration. Results are reported elsewhere at this conference by S.Gros [12].

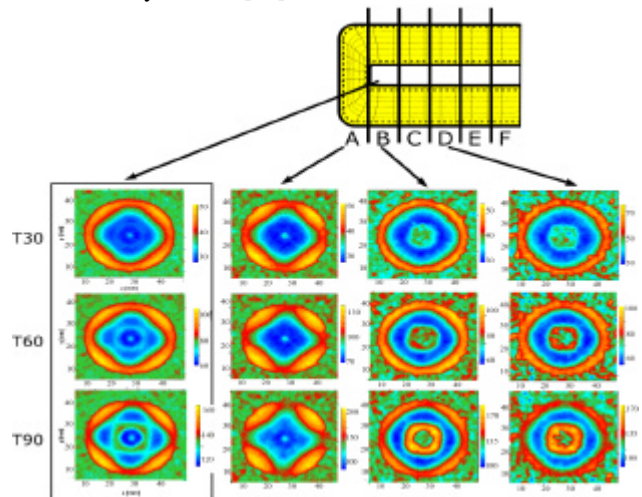

Fig 4 Plots of the rise time to 30%, 60% and 90% (T30, T60, T90) of full amplitude at different positions in the 6x6 detector. Results are shown for the core (superposition of all segments) and for segments in rings A, B and D.

The detector response characterization is a pre-requisite for pulse shape analysis (PSA). Some signature features of the pulse shapes must be identified from which the charge deposition positions can be uniquely determined. One method of characterizing the detector is to use the pulse rise time to various percentages of its maximum, for example a polar plot of rise times to 30%, 60% and 90% (T30, T60, T90) of the full height are shown in fig 4.

Fig 5 shows another representation of the rise time plots, indicating how the rise time varies with radius within one ring of segments. Any measured T90 time limits the radial position to just 2 possible values. The ambiguity is overcome by considering the T30 time which also generates 2 possible radii, but only one corresponds to the possible T90 values. So radial position can be determined from characterization plots obtained using the GRT4 cards.

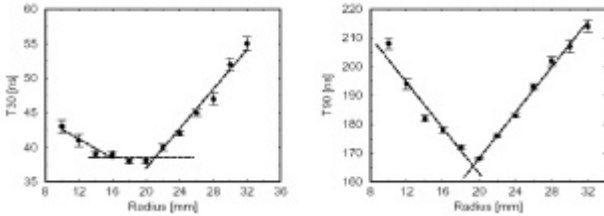

Fig 5 Rise Times to 30% and 90% of the full pulse amplitude. The V shaped T90 graphs have ambiguities at most values of T90, but these can be resolved by the T30 plots. Consider a hit at 24mm radius. The T90 rise time is 185ns so on the T90 graph we limit the radius to 2 possible values: 24mm or 14mm. At 24mm radius the T30 rise time is 43ns. On the T30 graph we limit the radius to another 2 possible values: 24mm or 10mm. So the 24mm radius is uniquely identifiable from the combination of these pairs of radii.

The radial position alone is not enough. The azimuthal position is also required. This can be obtained by considering the asymmetry of the charge induced in the neighbouring segments. Fig 6 shows a typical asymmetry plot for a cross section through the 6x6 detector.

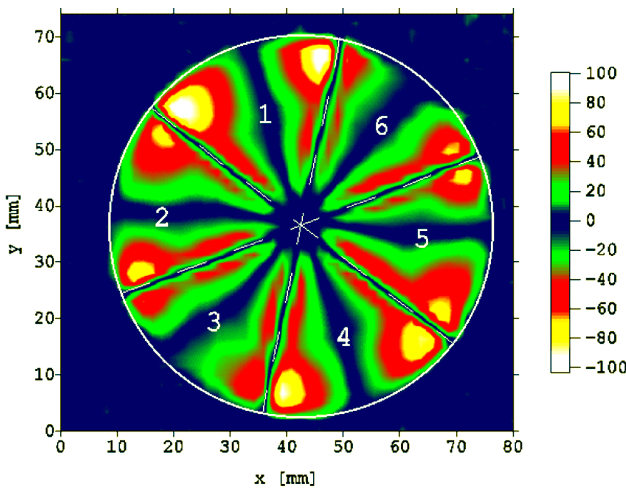

Fig 6 Asymmetry of charge induced in neighbouring segments. The plot shows the ratio of the difference divided by the sum of the charge induced in neighbour segments (Q_n). So for example in segment 4 the plot shows the values of $(Q_3 - Q_5)/(Q_3 + Q_5)$ for many different positions of the collimated scanning source.

Utilizing PSA as described here, the position determination obtained inside the 6x4 detector was found to vary from 0.8-4mm [11]. The variation is due to the complex electric field that exists inside a fully depleted germanium crystal. Improvements in the 4mm value can be expected once the E-field is fully characterized, indeed the scan data has provided invaluable insight into the E-field structure. The value of 0.8mm represents a true limitation due to the intrinsic momentum of the electrons in germanium. Analysis of the 6x6 detector data produces similar results.

V. ALGORITHMS IMPLEMENTED IN THE GRT4 CARDS

A hardware description language (VHDL) was used to program field programmable gate arrays (FPGA) in the GRT4 card. The moving window Deconvolution algorithm [7], [8] for energy determination has been successfully implemented in the GRT4 card [13]. The energy resolution of a small (33% efficiency) Germanium detector has been measured. The results are 2.05keV FWHM for the 1.3MeV ^{60}Co peak and 1.23keV FWHM for the 122keV peak in the ^{152}Eu spectrum. Count rate was 800Hz in both cases. A processing time of 11us was used to obtain these figures. These results are the same as those obtained with conventional analogue NIM electronics.

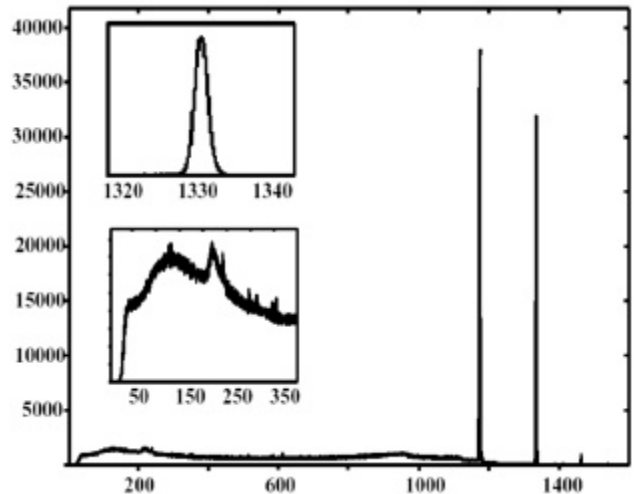

Fig 7 A spectrum collected using a GRT4 card with Moving Window Deconvolution running in the on-board FPGA. Insets show the detail of the peak and the leading edge trigger's threshold.

A simplified version of the Slope Conditioned Counting trigger algorithm [14] has also been implemented in the FPGAs.

VI. IMPROVEMENTS

There are lessons which could be learned from experience with the GRT4 cards. Firstly there is a need for communication between adjacent cards. Much of the useful

information which can be obtained by PSA needs information about the charge induced in neighbouring segments. In a 4 channel card this is only possible to a very limited extent and a high speed inter-card link would be useful. This could be implemented on the VME P2 connector.

Secondly, the VME interface was designed using only 16 bit data paths with block transfers (BLT). This is sufficient for the low data rates encountered during scanning, despite the fact that the VME bandwidth is shared across several GRT4 cards. However during the in-beam tests using the "oscilloscope" mode, generating 512 word traces without any zero suppression, the VME bandwidth was found to be a limitation. This restricts the wider use of the GRT4 cards in applications beyond detector characterization. So a new design should use 32 or 64 bit VME data widths and possibly implement 2-edge transfer protocols.

VII. CONCLUSION

The GRT4 card successfully fulfils the purpose for which it was designed, viz. characterizing detectors and learning about pulse shape analysis with segmented detectors. Position determination down to sub-millimeter precision has been achieved using traces collected in GRT4 cards. The energy resolution obtained by real time processing in the FPGAs is comparable to that obtained with conventional analogue shapers. A system comprising 2 crates of GRT4 cards has been successfully synchronized and run continuously for 1 week with no problems.

VIII. ACKNOWLEDGMENT

The authors wish to thank Paul Nolan and John Simpson for useful discussions about detectors. We are grateful to Juergen Eberth and his colleagues at IKP in Cologne University for their welcome and help during the in-beam tests, to Dirk Schwalm and his group for collaboration on the MWD implementation and to Rob Halsall for help with the VHDL.

IX. REFERENCES

- [1] C. Beausang, J. Simpson, "Large arrays of escape suppressed spectrometers for nuclear structure experiments" *J. Phys G* 22 (1996) p527
- [2] J. Gerl, "The AGATA Project" *Acta Phys. Pol. B34* (2003) p2481
- [3] K. Vetter, "Gamma-ray tracking: Utilizing new concepts in the detection of gamma-radiation" *Eur. Phys. J. A15* (2002) p265
- [4] C. J. Pearson, J. J. V. Dobon, P. H. Regan, P. J. Sellen, E. Morton, P. J. Nolan et al "Digital Gamma-Ray Tracking Algorithms in Segmented Germanium Detectors" *IEEE Transactions on nuclear science*, Vol. 49 No 3 (2002) p1209
- [5] J. Eberth, G. Pascovici, H. G. Thomas, N. Warr, D. Weisshaar, D. Habs et al "MINIBALL: a Ge detector array for radioactive ion beam facilities" *Progress in Particle & Nuclear Physics* 46, 389 (2001).
- [6] J. Simpson, F. Azaiez, G. deFrance, J. Fouan, J. Gerl, R. Julin et al "The EXOGAM Array: A Radioactive Beam Gamma-Ray Spectrometer" *APH N.S., Heavy Ion Physics* 11 (2000) 159-188

- [7] J. Stein, F. Scheuer, W. Gast and A. Georgiev "X-ray detectors with digitized preamplifiers" *Nucl. Instr. Methods B*, Vol. 113(1-4), June 1996, pp. 141-145
- [8] A. Georgiev, W. Gast and R. M. Lieder "An Analog-to-Digital Conversion Based on a Moving Window Deconvolution" *IEEE Transactions on Nuclear Science* 41 (1994) 1116
- [9] Multi Instance Data Acquisition System <http://npg.dl.ac.uk/MIDAS/>
- [10] MTSort <http://ns.ph.liv.ac.uk/software.html>
- [11] M. Descovich, Thesis, University of Liverpool 2002
- [12] S. A. A. Gros, J. Norman, A. J. Boston, J. R. Cresswell, C. J. Hall, W. I. Helsby et al, "Development of a Compton Camera with Segmented Germanium Detectors and Digital Read Out". *Compton Camera Conference at 2003 NSS*, submitted for publication.
- [13] M. Lauer, PhD thesis, University of Heidelberg, unpublished, to be submitted in 2004.
- [14] W. Gast, R. M. Lieder, L. Mihailescu, M. J. Rossewicz, H. Brands, A. Georgiev, et al "Digital signal processing and algorithms for gamma-ray tracking" *IEEE Transactions on Nuclear Science* 48 (2001) p2380-2384