

### Inline Fuel Filters

Sierra #	AP#	Application:
18-7828	13518	1/4" Small Capacity (For 1/4" Fuel Line)
18-7829	600	1/4" Large Capacity (For 1/4" Fuel Line) Replaces: 35-16494, 35-816296, 35-816296T
18-7830	1227	5/16" Replaces: 35-16494-1, 35-816296-1, 35-816296T1
18-7831	1679	3/8" —



---

### 18-3672 AP# 456 THERMOSTAT KIT

— CONTAINS —

Sierra #	AP #	Desc.	O.E. #
18-3553	403	Thermostat	75692
18-0182	424	Thermostat Gasket	27-62386

HP	Beg. S/N	End S/N	HP	Beg. S/N	End S/N
V135	A904646	& UP	V150 MAG II	C239553	4571651
V150	A904646	& UP	V150 MAG III	D082000	4825248
V150 XR4	C239553	C159199	V175	C100861	& UP
V150 XR6	D082000	& UP	V200	6435503	& UP



### 18-3569 THERMOSTAT KIT

Replaces: 803061T1

HP	Beg. S/N	End S/N	HP	Beg. S/N	End S/N
70 3 cyl.	A996142	& UP	100 4 cyl.	B209468	& UP
75 3 cyl.	C222000	& UP	115 4 cyl.	C100000	& UP
80 3 cyl.	A996142	& UP	125 4 cyl.	D283222	& UP
90 3 cyl.	A996142	& UP			

---

### 18-3553 AP# 403 THERMOSTAT (143°)

Replaces: 75692



### 18-3553/AP# 403 THERMOSTAT APPLICATION

HP	Beg. S/N	End. S/N	HP	Beg. S/N	End. S/N
7.5	5226935	& UP	V150	904646	& UP
9.8	5206550	& UP	V175	C100861	& UP
40	3336258	C159199	V200	6435503	& UP
50/60	D000750	& UP	V220	B117316	& UP
65	3547987	4571651	V225	5628028	& UP
70	4571652	4825248	V300/3.4L	5611648	& UP
70/75/80/90	A996142	& UP	XR4	C239553	D081999
100/115	B209468	& UP	Magnum II	C239553	D081999
V135	A904646	& UP			

---

### 18-3549 AP# 3149 THERMOSTAT (120°)

Replaces: 14586

For: 6, 7, 8, 9.9 & 15 HP Mercury/Mariner  
A197112 & Later



### 18-3549/AP# 3149 THERMOSTAT APPLICATION

MARINER	
HP	Serial #
6,8,9.9 (2 cyl.)	A197112 Later
Sea Pro 10	D038000 Later
15 (2 cyl.)	B292414 Later
18XD, 20XD, 25XD	B114231 Later
25 ( 2 cyl.) 25 Sea Pro	B238464 Later
30 (2 cyl.)	G055314 Later
45 Jet, 50, 55, 60 (3 cyl.)	G290585 Later
6.8.9.9 (2 cyl.)	A197112 Later
MERCURY	
Sea Pro 10	D038000 Later
15 (2 cyl.)	B292414 Later
18XD, 20XD, 25XD	B114231 Later
25 ( 2 cyl.) 25 Sea Pro	B238464 Later
30 (2 cyl.)	G055314 Later
45 Jet, 50, 55, 60 (3 cyl.)	G290585 Later

### 18-5896 AP# 1941 TEMPERATURE SENDER

Replaces: 12415  
1/8"-27NPT Threads



**OUTBOARD**



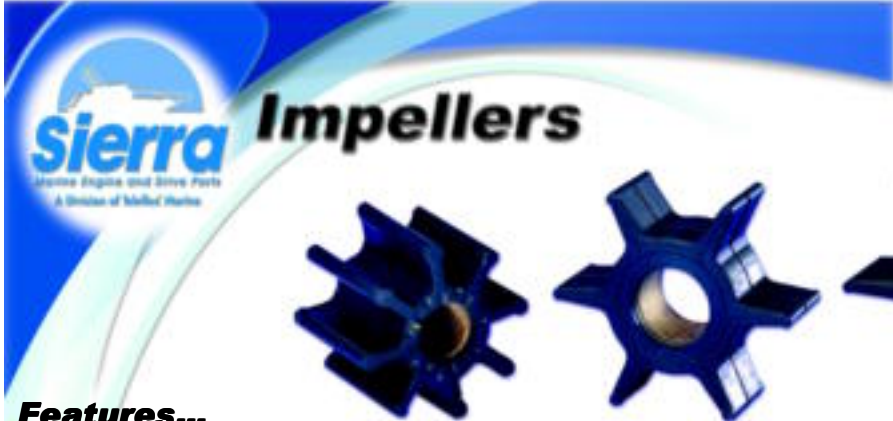











# MERCURY/MARINER



## Features...

- ★ Many impellers molded in-house to maintain high quality standards.
- ★ All impellers are made from nitril or neoprene rubber compounds.
- ★ Hub inserts match OEM materials and specifications.
- ★ Extensive inspection and testing on each impeller batch insures proper bonding and performance.

**OUTBOARD**

 <p><b>18-3007</b> <b>AP# 002</b> <b>IMPELLER</b> Replaces: 47-89983, 47-89983T</p>	 <p><b>18-3008</b> <b>IMPELLER</b> Replaces: 47-20813</p>	 <p><b>18-3012</b> <b>AP# 006</b> <b>IMPELLER</b> Replaces: 47-22748</p>	 <p><b>18-3017</b> <b>AP# 001</b> <b>IMPELLER</b> Replaces: 47-89984, 47-89984T4</p>												
 <p><b>IMPELLER</b></p> <table border="1"> <thead> <tr> <th>Sierra #</th> <th>AP #</th> <th>ID</th> <th>Replaces:</th> </tr> </thead> <tbody> <tr> <td><b>18-3039</b></td> <td><b>004</b></td> <td>.456"</td> <td>47-89981</td> </tr> <tr> <td><b>18-3054</b></td> <td><b>005</b></td> <td>.438"</td> <td>47-89980</td> </tr> </tbody> </table>	Sierra #	AP #	ID	Replaces:	<b>18-3039</b>	<b>004</b>	.456"	47-89981	<b>18-3054</b>	<b>005</b>	.438"	47-89980	 <p><b>18-3052</b> <b>AP# 003</b> <b>IMPELLER</b> Replaces: 47-89982</p>	 <p><b>18-3056</b> <b>AP# 1814</b> <b>IMPELLER</b> Replaces: 47-43026-2, T2</p>	
Sierra #	AP #	ID	Replaces:												
<b>18-3039</b>	<b>004</b>	.456"	47-89981												
<b>18-3054</b>	<b>005</b>	.438"	47-89980												
 <p><b>18-3057</b> <b>AP# 125</b> <b>IMPELLER</b> Replaces: 47-85089-3</p>	 <p><b>18-3062</b> <b>AP# 3753</b> <b>IMPELLER</b> Replaces: 47-42038-2</p>	 <p><b>18-3063</b> <b>AP# 2173</b> <b>IMPELLER</b> Replaces: 47-95611M</p>													
 <p><b>18-3066</b> <b>AP# 13145</b> <b>IMPELLER</b> Replaces: 47-11590M</p>	 <p><b>18-3067</b> <b>AP# 2008</b> <b>IMPELLER</b> Replaces: 47-84797M</p>	 <p><b>18-3069</b> <b>IMPELLER</b> Replaces: 47-81423M, 47-97108M</p>	 <p><b>18-3072</b> <b>AP# 2171</b> <b>IMPELLER</b> Replaces: 47-80395M</p>												

APPLICATIONS BEGIN ON PAGE 287

 <p><b>18-3073</b> AP# 2172 <b>IMPELLER</b> Replaces: 47-96305M</p>	 <p><b>18-3074</b> AP# 2007 <b>IMPELLER</b> Replaces: 47-84027M, 47-84027T</p>	 <p><b>18-8900</b> AP# 3754 <b>IMPELLER</b> Replaces: 47-19453</p>	 <p><b>18-3098</b> AP# 2170 <b>IMPELLER</b> Replaces: 47-16154-3</p>
 <p><b>18-3293</b> AP# 2677 <b>IMPELLER DRIVE KEY</b> Replaces: 28-43037 Also large O/B's</p>	 <p><b>18-3294</b> <b>IMPELLER KEY</b> Replaces: 28-81603M</p>	 <p><b>18-3300</b> <b>IMPELLER KEY</b> Replaces: 28-83444M For models: 40A, 40B, 40C</p>	 <p><b>18-3305</b> <b>IMPELLER KEY</b> Replaces: 28-81912M For models: 6C-D, 8C, 9.9C, 15C</p>
 <p><b>18-3109</b> AP# 601 <b>WATER TUBE GUIDE</b> Replaces: 23-29804, 23-29804T (Use with 18-3116 Housing)</p>	 <p><b>18-3014</b> <b>LOWER WATER PUMP SEAL</b> Replaces: 26-821310 For: 4-Stroke O/B's, 25/30/40/45/50 HP s/n OG760300 &amp; UP</p>	 <p><b>18-3013</b> <b>UPPER WATER PUMP SEAL</b> Replaces: 26-821309 For: 4-Stroke O/B's, 25/30/40/45/50 HP s/n OG760300 &amp; UP</p>	 <p><b>18-3110</b> <b>BUSHING/ W.P. HOUSING</b> Replaces: 26-38970 (Part of 18-3116 Housing)</p>
 <p><b>18-3151</b> <b>WATER COUPLING ASSEMBLY</b> Replaces: 816597A1</p>	 <p><b>18-3154</b> <b>WATER COUPLING ASSEMBLY</b> Replaces: 826763A</p>	 <p><b>18-3113</b> AP# 13156 <b>INSERT CUP</b> Replaces: 70977</p>	 <p><b>18-3114</b> AP# 042 <b>INSERT CUP</b> Replaces: 48752, 48752T</p>
 <p><b>18-3115</b> AP# 1025 <b>INSERT CUP</b> Replaces: 48753</p>	 <p><b>18-3435</b> <b>INSERT CUP</b></p>	 <p><b>18-3439</b> <b>INSERT CUP</b></p>	

**OUTBOARD**













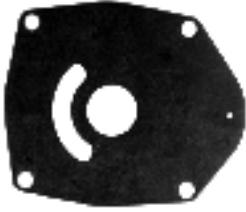

APPLICATIONS BEGIN ON PAGE 287

# MERCURY/MARINER

## Cooling System



**OUTBOARD**

 <p><b>18-3107</b> AP# 033 <b>IMPELLER PLATE</b> Replaces: 54705, 32768</p>	 <p><b>18-3117</b> AP# 030 <b>IMPELLER PLATE</b> Replaces: 32435</p>	 <p><b>18-3122</b> AP# 2187 <b>IMPELLER PLATE</b> Replaces: 817276</p>
 <p><b>18-3139</b> AP# 034 <b>IMPELLER PLATE</b> Replaces: 46895</p>	 <p><b>18-3116</b> AP# 043 <b>UPPER PUMP HOUSING</b> Replaces: 46-96148A1, 46-96148T</p>	 <p><b>18-3436</b> AP# 2000 <b>IMPELLER PLATE</b></p>
 <p><b>18-3118</b> AP# 1109 <b>UPPER PUMP HOUSING</b> Replaces: 46-77822A1</p>	 <p><b>18-3414</b> AP# 053 <b>PUMP BASE</b> Replaces: 46-96146A5</p>	 <p><b>18-3416</b> <b>PUMP BASE</b> Replaces: 46-96146A6</p>
 <p><b>18-3419</b> <b>PUMP BASE</b> Replaces: 46-42579A3</p>	 <p><b>18-3149-1</b> AP# 13158 <b>WATER PUMP KIT</b> Replaces: 46-42040A5, 46-42040T5</p>	 <p><b>18-3422</b> AP# 1110 <b>PUMP BASE</b> Replaces: 46-77516A1</p>
 <p><b>18-3423</b> AP# 1112 <b>PUMP BASE</b> Replaces: 46-73640A1</p>	 <p><b>18-3424</b> AP# 1114 <b>PUMP BASE</b> Replaces: 46-77177A1</p>	 <p><b>18-3445</b> <b>WATER PUMP BASE</b> Replaces: 46-812966A7 For: 40-60 HP</p>

APPLICATIONS BEGIN ON PAGE 287





**Features...**

- ★ Complete kits contain all of the parts necessary to do the job right.
- ★ All components are manufactured from premium materials and held to stringent quality standards.
- ★ Many exclusive products you can't get from any other after market supplier.

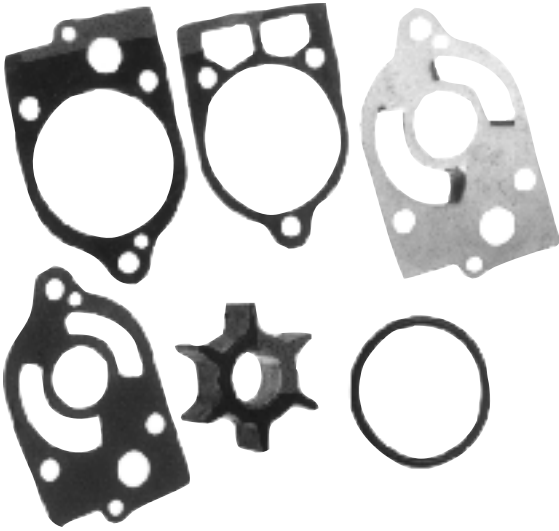

**18-3207<sup>①</sup>**  
**18-3207N<sup>②</sup>**  
**AP# 057**  
**IMPELLER REPAIR KIT**  
Replaces: 47-89983T2, 47-89983Q1  
— CONTAINS —

Sierra#	Desc.	O.E. #	Qty.
18-3007	Impeller	47-89983	1
18-2945	Drain Gasket	12-20260,12-19183	2
18-2823	Low Water Pump Base to Face Plate Gasket	27-32769,27-19553	1
18-2824	Upper Face Plate to Pump Body Gasket	27-32770	1
18-2825	Water Pump Base Gasket	27-32771,27-19551	1
18-2841	Water Pump Base Gasket	27-77417,27-19552	1
18-2948	Rubber Washer	12-49221-1	1
18-3107	Plate	54705	1
18-7155	O-Ring	25-26855	1
18-7174	O-Ring	25-45711	1
18-7115	O-Ring	25-26722	1

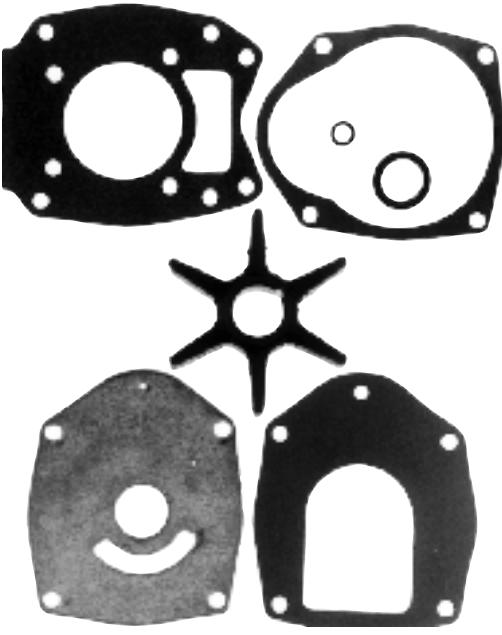

**18-3214<sup>①</sup>**  
**18-3214N<sup>②</sup>**  
**AP# 1811**  
**IMPELLER REPAIR KIT**  
Replaces: 47-43026T6, 47-43026T8, 47-43026T11  
— CONTAINS —

Sierra#	Desc.	O.E. #	Qty.
18-2564	Water Pump Base to Face Plate Gasket	27-43033-1	1
18-2565	Water Pump Base to Gear Housing Gasket	27-43047-1	1
18-2566	Face Plate to Water Pump Cover Gasket	27-817277	1
18-2944	Seal Ring	26-45577	1
18-3056	Impeller	47-43026-1	1
18-3122	Impeller Plate	817276	1
18-7420	O-Ring	25-21836	1

APPLICATIONS BEGIN ON PAGE 287-ALL PARTS SHOWN ARE INCLUDED IN KIT. 18-#'S LISTED, ARE AVAILABLE INDIVIDUALLY.

① Display Pack      ② Bulk Pack

**OUTBOARD**

# MERCURY/MARINER

## Cooling System





**18-3215<sup>①</sup>**  
**18-3215N<sup>②</sup>**  
**AP# 1179**  
**IMPELLER REPAIR KIT**  
 Replaces: 47-85089T7  
 — CONTAINS —

Sierra#	Desc.	O.E.#	Qty.
18-2560	Impeller Washer Gasket	12-86645	2
18-2561	Gear Housing to Face Plate Gasket	27-85087	1
18-2562	Gear Housing to Face Plate Gasket	27-99326-1	1
18-3057	Impeller	47-85089-3	1
18-7419	O-Ring	25-69202	1

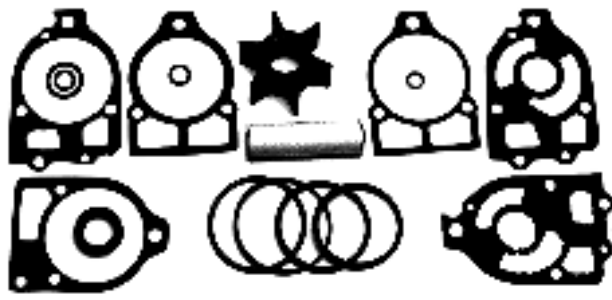

**18-3216**  
**IMPELLER REPAIR KIT**  
 Replaces: 47-59362A4  
 Fits: 1996-97 7.4L MIE MPI(LH) Gen VI GM 454 V8, 1996-97, 7.4L TBI MIE(LH) Gen VI GM 454 V8, 1996-97 8.2L MIE MPI(LH) Gen VI GM 502 V8.



**18-3217<sup>①</sup>**  
**18-3217N<sup>②</sup>**  
**IMPELLER REPAIR KIT**  
 Similar to: 46-96148A5 without base or housing  
 — CONTAINS —

Sierra#	Desc.	O.E.#	Qty.
18-3109	Water Tube	23-29804	1
18-3017	Impeller	47-89984	1
18-2919	Water Pump Gasket	27-42631-1	1
18-3110	Grommet	26-38970	1
18-2945	Drain Gasket	12-20260, 12-19183	2
18-2826	Water Pump Base to Gear Housing Gasket	27-85610	1
18-2914	Water Pump Gasket	27-85608-1	1
18-2915	Water Pump Gasket	27-85609-1	1
18-2944	Seal Ring	26-45577	1
18-3117	Plate	32435	1
18-7158	O-Ring	25-30613	1
18-7162	O-Ring	25-33145	1
18-7173	O-Ring	25-30224	1
18-7176	O-Ring	25-90011	1
18-2801	Water Pump Gasket	27-32438	1
18-7196	O-Ring	25-38099	1
18-7426	O-Ring	35-30271	1

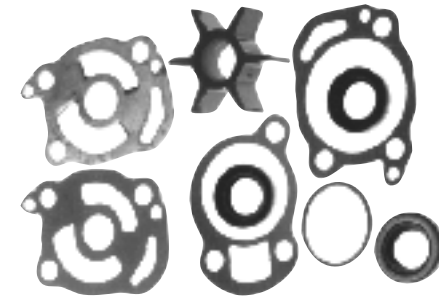

**18-3252**  
**AP# 058**  
**IMPELLER REPAIR KIT**  
 Replaces: 47-89982T1  
 — CONTAINS —

Sierra#	Desc.	O.E.#	Qty.
18-2004	Oil Seal	26-20070	2
18-2006	Oil Seal	26-33467	1
18-2827	Upper Face Plate to Water Pump Body Gasket	27-39623	1
18-2828	Lower Water Pump Base to Face Plate	27-39625	1
18-2829	Water Pump Base to Gear Housing Gasket	27-39626	1
18-3052	Impeller	47-89982	1
18-7164	O-Ring	25-33466	1

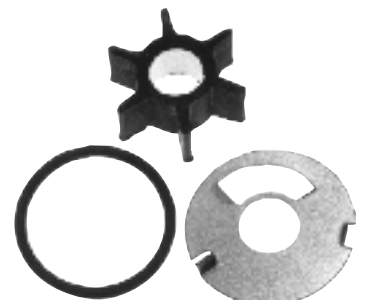

**18-3239**  
**AP# 059**  
**IMPELLER REPAIR KIT**  
 — CONTAINS —

Sierra#	Desc.	O.E.#	Qty.
18-3039	Impeller	47-89981	1
18-3139	Impeller Plate	46895	1
18-7409	O-Ring	—	1

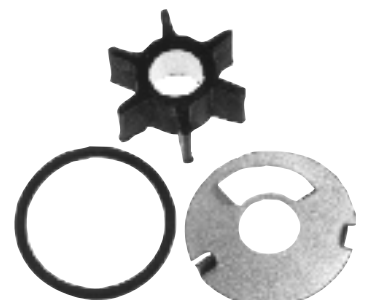

**18-3239**  
**AP# 059**  
**IMPELLER REPAIR KIT**  
 — CONTAINS —

Sierra#	Desc.	O.E.#	Qty.
18-3039	Impeller	47-89981	1
18-3139	Impeller Plate	46895	1
18-7409	O-Ring	—	1

APPLICATIONS BEGIN ON PAGE 287 - ALL PARTS SHOWN ARE INCLUDED IN KIT. 18-#'S LISTED, ARE AVAILABLE INDIVIDUALLY.

① Display Pack      ② Bulk Pack



**18-3314**  
**AP# 13169**  
**COMPLETE PUMP HOUSING KIT**  
— CONTAINS —

Sierra#	Desc.	O.E.#	Qty.
18-3109	Water Tube Guide	23-29804	1
18-3017	Impeller	47-89984	1
18-3116	Housing	46-96148A1	1
18-3414	Base	46-96146A5	1
18-2919	Water Pump Gasket	27-42631-1	1
18-3110	Grommet	26-38970	1
18-2945	Drain Gasket	12-20260, 12-19183	2
18-2826	Water Pump Base to Gear Housing Gasket	27-85610-1	1
18-2914	Water Pump Gasket	27-85608-1	1
18-2915	Water Pump Gasket	27-85609-1	1
18-2944	Seal Ring	26-45577	1
18-3117	Plate	32435	1
18-7158	O-Ring	25-30613	1
18-7162	O-Ring	25-33145	1
18-7173	O-Ring	25-30224	1
18-7176	O-Ring	25-90011	1
18-2801	Gasket	27-32438	1
18-7196	O-Ring	25-38099	1
18-7426	O-Ring	35-30271	1



**18-3316**  
**AP# 13170**  
**COMPLETE PUMP HOUSING KIT**  
Replaces: 46-78400A2  
— CONTAINS —

Sierra#	Desc.	O.E.#	Qty.
18-3109	Water Tube Guide	23-29804	1
18-3017	Impeller	47-89984	1
18-3116	Housing	46-96148A1	1
18-3414	Base	46-96146A6	1
18-2919	Water Pump Gasket	27-42631-1	1
18-3110	Grommet	26-38970	1
18-2945	Drain Gasket	26-20260, 12-19183	2
18-2826	Water Pump Base to Gear Housing Gasket	27-85610-1	1
18-2914	Water Pump Gasket	27-85608-1	1
18-2915	Water Pump Gasket	27-85609-1	1
18-2944	Seal Ring	26-45577	1
18-3117	Plate	32435	1
18-7158	O-Ring	25-30613	1
18-7162	O-Ring	25-33145	1
18-7173	O-Ring	25-30224	1
18-7176	O-Ring	25-90011	1
18-2801	Gasket	27-32438	1
18-7196	O-Ring	25-38099	1
18-7426	O-Ring	35-30271	1



**18-3319**  
**AP # 048**  
**COMPLETE PUMP HOUSING KIT**  
Replaces: 46-42579A4  
— CONTAINS —

Sierra#	Desc.	O.E.#	Qty.
18-3109	Water Tube Guide	23-29804	1
18-3017	Impeller	47-89984	1
18-3116	Housing	46-96148A1	1
18-3419	Base	46-42579A3	1
18-2919	Water Pump Gasket	27-42631-1	1
18-3110	Grommet	26-38970	1
18-2945	Drain Gasket	26-20260, 12-19183	2
18-2826	Water Pump Base to Gear Housing Gasket	27-85610-1	1
18-2914	Water Pump Gasket	27-85608-1	1
18-2915	Water Pump Gasket	27-85609-1	1
18-2944	Seal Ring	26-45577	1
18-3117	Plate	32435	1
18-7158	O-Ring	25-30613	1
18-7162	O-Ring	25-33145	1
18-7173	O-Ring	25-30224	1
18-7176	O-Ring	25-90011	1
18-2801	Gasket	27-32438	1
18-7196	O-Ring	25-38099	1
18-7426	O-Ring	35-30271	1



**18-3507**  
**AP# 1171**  
**UPPER PUMP HOUSING KIT**  
**(Without Base)**  
Replaces: 46-60366A1  
— CONTAINS —

Sierra#	Desc.	O.E.#	Qty.
18-3007	Impeller	47-89983	1
18-3118	Upper Pump Housing	46-77822A1	1
18-2945	Drain Gasket	12-20260, 12-19183	2
18-2823	Lower Water Pump Base to Face Plate Gasket	27-32769, 27-19553	1
18-2824	Upper Face Plate To Body Gasket	27-32770, 27-19551	1
18-2825	Water Pump Base	27-32771	1
18-2841	Water Pump Base	27-77417, 27-19552	1
18-2948	Drain Plug	12-49221-1	1
18-3107	Plate	54705	1
18-7155	O-Ring	25-26855	1
18-7174	O-Ring	25-45711	1
18-7115	O-Ring	25-26722	1

APPLICATIONS BEGIN ON PAGE 287 - ALL PARTS SHOWN ARE INCLUDED IN KIT. 18-#'S LISTED, ARE AVAILABLE INDIVIDUALLY.

# MERCURY/MARINER

## Cooling System



OUTBOARD

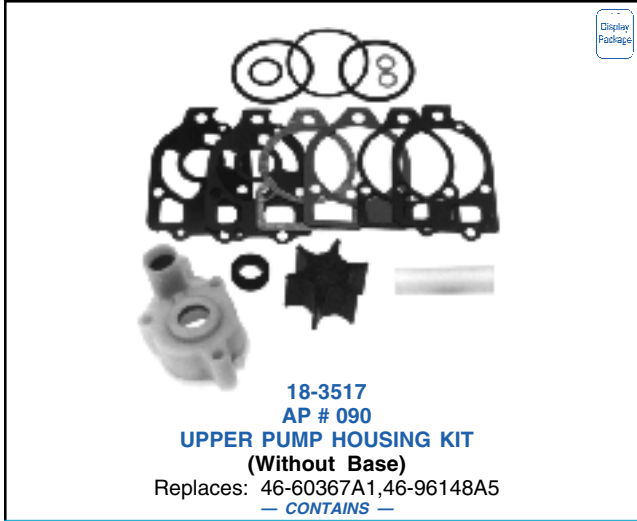

Sierra#	Desc.	O.E. #	Qty.
18-3109	Water Tube	23-29804	1
18-3017	Impeller	47-89984	1
18-3116	Housing	46-96148A1	1
18-2919	Water Pump Gasket	27-42631-1	1
18-3110	Grommet	26-38970	1
18-2945	Drain Gasket	26-20260, 12-19183	2
18-2826	Water Pump Base to Gear Housing Gasket	27-85610-1	1
18-2914	Water Pump Gasket	27-85608-1	1
18-2915	Water Pump Gasket	27-85609-1	1
18-2944	Seal Ring	26-45577	1
18-3117	Plate	32435	1
18-7158	O-Ring	25-30613	1
18-7162	O-Ring	25-33145	1
18-7173	O-Ring	25-30224	1
18-7176	O-Ring	25-90011	1
18-2801	Water Pump Gasket	27-32438	1
18-7196	O-Ring	25-38099	1
18-7426	O-Ring	35-30271	1



Sierra#	Desc.	O.E. #	Qty.
18-3007	Impeller	47-89983	1
18-3118	Upper Pump Housing	46-77822A1	1
18-3422	Base Water Pump	46-77516A1	1
18-2945	Drain Gasket	12-20260, 12-19183	2
18-2823	Lower Water Pump Base to Face Plate Gasket	27-32769, 27-19553	1
18-2824	Upper Face Plate To Body Gasket Plate To Body	27-32770, 27-19551	1
18-2825	Water Pump Base	27-32771	1
18-2841	Water Pump Base	27-77417, 27-19552	1
18-2948	Drain Plug	12-49221-1	1
18-3107	Plate	54705	1
18-7155	O-Ring	25-26855	1
18-7174	O-Ring	25-45711	1
18-7115	O-Ring	25-26722	1



Sierra#	Desc.	O.E. #	Qty.
18-3007	Impeller	47-89983	1
18-3118	Upper Pump Housing	46-77822A1	1
18-3423	Base Water Pump	46-73640A1	1
18-2945	Drain Gasket	12-20260, 12-19183	2
18-2823	Lower Water Pump Base to Face Plate Gasket	27-32769, 27-19553	1
18-2824	Upper Face Plate To Body Gasket	27-32770, 27-19551	1
18-2825	Water Pump Base Gasket	27-32771	1
18-2841	Water Pump Base Gasket	27-77417, 27-19552	1
18-2948	Drain Plug	12-49221-1	1
18-3107	Plate	54705	1
18-7155	O-Ring	25-26855	1
18-7174	O-Ring	25-45711	1
18-7115	O-Ring	25-26722	1



Sierra#	Desc.	O.E. #	Qty.
18-3007	Impeller	47-89983	1
18-3118	Upper Pump Hsg.	46-77822A1	1
18-3424	Base Water Pump	46-77177A1	1
18-2945	Drain Gasket	12-20260, 12-19183	2
18-2823	Lower Water Pump Base to Face Plate Gasket	27-32769, 27-19553	1
18-2824	Upper Face Plate To Body Gasket	27-32770, 27-19551	1
18-2825	Water Pump Base Gasket	27-32771	1
18-2841	Water Pump Base Gasket	27-77417, 27-19552	1
18-2948	Drain Plug	12-49221-1	1
18-3107	Plate	54705	1
18-7155	O-Ring	25-26855	1
18-7174	O-Ring	25-45711	1
18-7115	O-Ring	25-26722	1

APPLICATIONS BEGIN ON PAGE 287 - ALL PARTS SHOWN ARE INCLUDED IN KIT. 18-#'S LISTED, ARE AVAILABLE INDIVIDUALLY.





**18-3571**  
**UPPER HOUSING KIT**  
Replaces: 817275A1  
V-6 outboard



**18-3572**  
**UPPER HOUSING KIT**  
Replaces: 817275A2  
V-6 outboard



**18-3148**  
**AP# 2077**  
**WATER PUMP REPAIR KIT**  
**Without Housing**  
Replaces: 46-84277M, 46-84277T  
— CONTAINS —



**18-3446**  
**WATER PUMP KIT**  
Replaces: 46-70941A3  
For: 4/4.5 HP  
— CONTAINS —

Sierra#	Desc.	O.E.#	Qty.
18-0768	Gasket,Wear Plate	—	1
18-3074	Impeller	47-84027M	1
18-3305	Woodruff Key	28-8192M	1

Sierra#	Desc.	O.E.#	Qty.
18-3039	Impeller	47-89981	1
18-3139	Impeller Plate	46895	1



**18-3447**  
**WATER PUMP KIT**  
Replaces: 46-46893A6  
For: 3.9/4 HP  
— CONTAINS —

Sierra#	Desc.	O.E.#	Qty.
18-3012	Impeller	47-89980	1
18-3139	Impeller Plate	46895	1



**18-3448**  
**WATER PUMP KIT**  
Replaces: 46-48744A3  
For: 20 HP 1967-80  
— CONTAINS —

Sierra#	Desc.	O.E.#	Qty.
18-3052	Impeller	47-89982	1
18-2827	Upper Face Plate Gasket	27-39623	1
18-2828	Lower Face Plate Gasket	27-39625	1
18-2829	Water Pump Base Gasket	27-39626	1

APPLICATIONS BEGIN ON PAGE 287 - ALL PARTS SHOWN ARE INCLUDED IN KIT. 18-#'S LISTED, ARE AVAILABLE INDIVIDUALLY.

**OUTBOARD**

# MERCURY/MARINER

## Cooling System



**18-3570**  
**WATER PUMP KIT**  
Replaces: 817275A1, 817275A2  
— CONTAINS —

Sierra#	Desc.	O.E.#	Qty.
NSS	Water Pump Housing	—	1
18-3056	Impeller	47-430262	1
18-2599	Face Seal & Tool	26-816575A2	1
18-3122	Impeller Plate	817276	1

HP	Beg. S/N	End. S/N	HP	Beg. S/N	End. S/N
<b>817275A2 APPLICATION</b>					
<b>817275A2 APPLICATION (Cont.)</b>					
40 (4 stroke)			80 Jet	OD283222	& UP
(4 cyl.) Bigfoot	OT228405	& UP	90 (3 cyl.)	OA996142	& UP
50 (4 stroke)			90 (4 stroke)	OG960500	& UP
935cc Big Foot	OG231123	OT178499	100 (4 cyl.)	OB209468	& UP
50 (4 stroke)			115 (4 cyl.)	OC100000	& UP
996cc Big Foot	OT178500	& UP	125 (4 cyl.)	OD283222	& UP
60 (3 cyl.)			<b>817275A1 APPLICATION</b>		
Bigfoot	OD000750	& UP	45 (4 stroke)		
60 (4 stroke)			Bigfoot Bodensee	OG231123	& UP
Bigfoot	OT178500	& UP	V-200 DFI (3.0L)	OG386496	OG589999
65 Jet	OC283222	& UP	V-200 DFI (3.0L)	OG590000	& UP
70 (3 cyl.)	OA996142	& UP	V-225 (3.0L)		
75 (3 cyl.)	OC222000	& UP	Carb & EFI	OD280813	& UP
75 (4 stroke)	OG960500	& UP	V-225 DFI	OG590000	& UP
80 (3 cyl.)	OA996142	& UP	V-250 (3.0L) EFI	OG129222	& UP

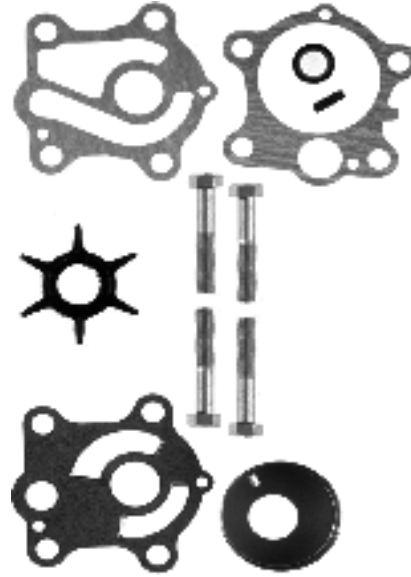

**18-3425**  
**AP# 2079**  
**WATER PUMP REPAIR KIT**  
Without Housing  
Replaces: 84188M, 84188T  
— CONTAINS —

Sierra#	Desc.	O.E.#	Qty.
18-0292	Wear Plate to Pump Housing Gasket	27-81417M	1
18-3435	Insert Cup	—	1
18-0294	Wear Plate to Pump Base Gasket	—	1
18-3069	Impeller	47-81423M, 47-97108M	1
18-0256	Bolt	—	2
18-0258	Bolt	—	2
18-3436	Impeller Plate	—	1



**18-3426**  
**AP# 13190**  
**WATER PUMP REPAIR KIT**  
With Housing  
Replaces: 42431M, 97793M, 97793T  
— CONTAINS —

Sierra#	Desc.	O.E.#	Qty.
18-3438	Impeller Plate	—	1
18-3067	Impeller	47-84797M	1
18-3437	Insert Cup	—	1
18-0777	Seal Cover Gasket	27-41273M	1
18-0774	Wear Plate Gasket	—	1



**18-3427**  
**AP# 13191**  
**WATER PUMP REPAIR KIT**  
With Housing  
Replaces: 95611M  
— CONTAINS —

Sierra#	Desc.	O.E.#	Qty.
18-0773	Wear Plate Gasket	—	1
18-3438	Impeller Plate	—	1
18-3067	Impeller	47-84797M	1
18-3439	Insert Cup	—	1
18-0774	Wear Plate Gasket	—	1

APPLICATIONS BEGIN ON PAGE 287 - ALL PARTS SHOWN ARE INCLUDED IN KIT. 18-#S LISTED, ARE AVAILABLE INDIVIDUALLY.

OUTBOARD



# MERCURY/MARINER Cooling System

MARINER COOLING SYSTEM APPLICATION							
Mariner Models	S/N Code	S/N	Impeller	Plate	Impeller Cup	Impeller Repair Kit	Complete Kit
2A	646	All	18-3072	—	—	—	—
2B	6A1	All	18-3072	—	—	—	—
4A	6E0	All	18-3073	—	—	—	—
5C	6E3	All	18-3073	—	—	—	—
6C	6H8	All	18-3066	—	—	—	—
6D	6H6	All	18-3066	—	—	—	—
8A(M)	655	000000-000300	18-3063	—	—	—	—
8A(ML)	655	000000-300101	18-3063	—	—	—	—
8B(M)	677	000101 & Up	18-3063	—	—	—	—
8B(ML)	677	300101 & Up	18-3063	—	—	—	—
8C	6G1	All	18-3066	—	—	—	—
9.9C	682	All	18-3074	—	—	18-3148	—
15A(M)	651	000285 & Below	18-3063	—	—	—	—
15A(ML)	651	3000100 & Below	18-3063	—	—	—	—
15C	684	All	18-3074	—	—	18-3148	—
20C(M)	6A9	000101-005810	18-3067	18-3436	—	18-3426	—
20C(ML)	6A9	300101-306542	18-3067	18-3436	—	18-3426	—
20C(E)	6A9	250101-250819	18-3067	18-3436	—	18-3426	—
20C(EL)	6A9	550101-550693	18-3067	18-3436	—	18-3426	—
20C(M)	6A9	010112 & Up	18-3067	—	18-3439	—	18-3427
20C(ML)	6A9	306543 & Up	18-3067	—	18-3439	—	18-3427
20C(E)	6A9	250820 & Up	18-3067	—	18-3439	—	18-3427
20C(EL)	6A9	550694 & Up	18-3067	—	18-3439	—	18-3427
25C(M)	695	000101-014870	18-3067	18-3436	—	—	18-3426
25C(ML)	695	000000-312185	18-3067	18-3436	—	—	18-3426
25C(E)	695	000000-252290	18-3067	18-3436	—	—	18-3426
25C(EL)	695	000000-553575	18-3067	18-3436	—	—	18-3426
25C(M)	695	014871 & Up	18-3067	—	18-3439	—	18-3427
25C(ML)	695	312186 & Up	18-3067	—	18-3439	—	18-3427
25C(E)	695	252291 & Up	18-3067	—	18-3439	—	18-3427
25C(EL)	695	553576 & Up	18-3067	—	18-3439	—	18-3427
28	664	All	18-3067	—	—	—	—
30	689	All	18-3067	—	—	—	—
30A(M)	689	000366-014805	18-3067	18-3436	—	—	18-3426
30A(ML)	689	301911-315315	18-3067	18-3436	—	—	18-3426
30A(E)	689	100251-103275	18-3067	18-3436	—	—	18-3426
30A(EL)	689	401216-407815	18-3067	18-3436	—	—	18-3426
30A(M)	689	022059 & Up	18-3067	—	18-3439	—	18-3427
30A(ML)	689	321377 & Up	18-3067	—	18-3439	—	18-3427
30A(E)	689	105325 & Up	18-3067	—	18-3439	—	18-3427
30A(EL)	689	411947 & Up	18-3067	—	18-3439	—	18-3427
48/48W	670	All	18-3069	18-3436	18-3435	18-3425	—
55/W55	663	All	18-3069	18-3436	18-3435	18-3425	—
60	675,6F0	All	18-3069	18-3436	18-3435	18-3425	—

**OUTBOARD**

# MERCURY/MARINER

## Cooling System



### MERCURY COOLING SYSTEM APPLICATION

HP	Beginning Serial #	Ending Serial #	Impeller	Impeller Plate	Insert Cup	Upper Housing	Base	Impeller Repair Kit	Upper Kit	Complete Kit
3.3 (with shift)	D901217	& UP	18-3098	—	—	—	—	—	—	—
3.5	358136	6202172	18-3012	—	—	—	—	—	—	—
3.5	6202173	& UP	18-3054	—	—	—	—	—	—	—
3.6	5404657	& UP	18-3054	—	—	—	—	—	—	—
3.9	1655013	2498135	18-3012	18-3139	—	—	—	—	—	18-3447
4	2498136	4107219	18-3039	18-3139	—	—	—	18-3239	—	—
40/4 (2 cyl.)	5589202	& UP	18-3054	—	—	—	—	—	—	—
4 (made in USA)	5595532	9075838	18-3054 <sup>②</sup>	18-3139	—	—	—	—	—	—
4 (made in USA)	5595532	9075838	18-3039 <sup>③</sup>	18-3139	—	—	—	18-3239 <sup>③</sup>	—	18-3446
4 (1 cyl.)	A809601	& UP	18-3098	—	—	—	—	—	—	—
4.5	4107220	5595531	18-3039	18-3139	—	—	—	18-3239 <sup>①</sup>	—	18-3446
4.5	5595532	& UP	18-3054 <sup>②</sup>	18-3139	—	—	—	—	—	—
4.5	5595532	& UP	18-3039 <sup>③</sup>	18-3139	—	—	—	18-3239 <sup>③</sup>	—	18-3446
5	338136	574128	18-3012	—	—	—	—	—	—	—
5 (1 cyl.)	A809601	& UP	18-3098	—	—	—	—	—	—	—
6	888005	1916138	18-3012	—	—	—	—	—	—	—
6	2193818	2529894	18-3039	18-3139	—	—	—	18-3239	—	—
6	A197112	& UP	18-3062	—	—	—	—	—	—	—
7.5	2529895	4131609	18-3039	18-3139	—	—	—	—	—	18-3447
7.5	4131610	5226934	18-3039	18-3139	—	—	—	18-3239	—	18-3446
7.5	5206550	& UP	18-3054 <sup>②</sup>	—	—	—	—	—	—	—
7.5	5206550	& UP	18-3039	18-3139	—	—	—	18-3239	—	18-3446
8	A197112	& UP	18-3062	—	—	—	—	—	—	—
8 (4-stroke Bodensee)	G760300	& UP	18-3062	—	—	—	—	—	—	—
110 (9.8)	1865779	4126459	18-3039	18-3139	—	—	—	18-3239	—	18-3447
110 (9.8)	4126460	5206549	18-3039	18-3139	—	—	—	18-3239	—	18-3446
9.8	5206550	& UP	18-3054 <sup>②</sup>	—	—	—	—	—	—	—
9.8	5206550	& UP	18-3039	18-3139	—	—	—	18-3239	—	18-3446
9.9	A197112	& UP	18-3062	—	—	—	—	—	—	—
9.9 (4 Stroke)	G760300	& UP	18-3062	—	—	—	—	—	—	—
XR10 SeaPro	D038000	& UP	18-3062	—	—	—	—	—	—	—
10	500022	1057993	18-3008	—	—	—	—	—	—	—
15	B292414	& UP	18-3062	—	—	—	—	—	—	—
15 SeaPro	G044365	& UP	18-3062	—	—	—	—	—	—	—
16	700000	& UP	18-3008	—	—	—	—	—	—	—
18	5837437	& UP	18-3057	—	—	—	—	18-3215	—	—
20	860970	1292909	18-3008	—	—	—	—	—	—	—
20	2827677	6443972	18-3052	18-3152	—	—	—	18-3252	—	18-3448
20	6443973	& UP	18-3057	—	—	—	—	18-3215	—	—
22	1158546	1238089	18-3008	—	—	—	—	—	—	—
25,25XD,25 Sea Pro	5705532	& UP	18-3057	—	—	—	—	18-3215	—	—
25 (3 cyl.)	E268781	& UP	18-3057	—	—	—	—	18-3215	—	—
30	950250	1260724	18-3008	—	—	—	—	—	—	—
30	1271884	1448139	18-3007	18-3107	—	—	—	18-3207	18-3507	—
30 Jet	C159200	G589999	18-3007	18-3107	18-3115	18-3118	18-3424	18-3207	18-3507	18-3324
30 Jet	G590000	& UP	18-3057	—	—	—	—	—	—	—
30 (2 cyl)	G053314	& UP	18-3057	—	—	—	—	—	—	—
30 (2 cyl.) 430 cc Lightning	G5755000	& UP	18-3098	—	—	—	—	—	—	—
35	1217222	1448139	18-3007	—	—	—	—	—	—	—
35	1571114	1960826	18-3007	18-3107	—	—	—	18-3207	18-3507	—
35	1960827	6445652	18-3007	18-3107	—	—	—	18-3207	18-3507	—

① For S/N 5206550 and UP .456 I.D. Only

② .438 I.D. Only

③ .456 I.D. Only

④ Models with insulator on water pump housing bolts

⑤ Models without insulator on water pump housing bolts

OUTBOARD





# MERCURY/MARINER Cooling System

MERCURY COOLING SYSTEM APPLICATION										
HP	Beginning Serial #	Ending Serial #	Impeller	Impeller Plate	Insert Cup	Upper Housing	Base	Impeller Repair Kit	Upper Kit	Complete Kit
35	6445653	& UP	18-3007	18-3107	18-3115	18-3118	18-3424	18-3207	18-3507	18-3324
40	941751	1224480	18-3008	—	—	—	—	—	—	—
40	1224481	1476509	18-3007	—	—	—	—	—	—	—
40	2874704	4362214	18-3007	18-3107	18-3115	18-3118	18-3422	18-3207	18-3507	18-3322
40	4362215	4860102	18-3007	18-3107	18-3115	18-3118	18-3423	18-3207	18-3507	18-3323
40 (2 cyl)	4860103	6445653	18-3007	18-3107	18-3115	18-3118	18-3424	18-3207	18-3507	18-3324
40 (2 cyl)	G053314	& UP	18-3057	—	—	—	—	—	—	—
40 (3 cyl)	G531301	& UP	18-3057	—	—	—	—	—	—	—
40 (4 cyl)	C159200	& UP	18-3007	18-3107	18-3115	18-3118	18-3424	18-3207	18-3507	18-3324
40 (4-stroke,Std)	G231123	G760299	18-3057	—	—	—	—	—	—	—
40 (4-stroke) 2:1 ratio	G760300	T408999	18-3057	—	—	—	—	—	—	—
40 (4-stroke, 4 cyl.) 1.83:1 ratio	T228405	& UP	18-8900	—	—	—	18-3445	—	—	—
40 (4-stroke, 4 cyl.) 2.31:1 ratio	T228405	& UP	18-3056	—	—	—	—	18-3214	—	—
40 (EFI 4-stroke) 1.83:1 ratio	T409000	& UP	18-8900	—	—	—	18-3445	—	—	—
40 (EFI 4-stroke) 2.31:1 ratio	T409000	& UP	18-3056	—	—	—	—	18-3214	—	—
40 (4-stroke,Bigfoot)& 2.31: ratio	G231123	& UP	18-3056	—	—	—	—	18-3214	—	—
45	1279685	1476509	18-3007	—	—	—	—	—	—	—
45	5531630	& UP	18-3007	18-3107	18-3115	18-3118	18-3424	18-3207	18-3507	18-3324
45 Jet (3 cyl)	D000750	& UP	18-8900	—	—	—	—	—	—	—
45 (4-stroke,std) Bodensee	G231123	& UP	18-3057	—	—	—	—	—	—	—
45 (4-stroke,bigfoot) Bodensee	G231123	& UP	18-3056	—	—	—	—	18-3214	—	—
50	1421113	1521913	18-3007	—	—	—	—	—	—	—
50	1521914	2514918	18-3007	18-3107	—	—	—	18-3207	18-3507	—
50	2514919	4357639	18-3007	18-3107	18-3115	18-3118	18-3422	18-3207	18-3507	18-3322
50	4357640	4962055	18-3007	18-3107	18-3115	18-3118	18-3423	18-3207	18-3507	18-3323
50 (4 cyl)	4962056	& UP	18-3007	18-3107	18-3115	18-3118	18-3424	18-3207	18-3507	18-3324
50 (3 cyl)	6428681	D000749	18-3007	18-3107	18-3115	18-3118	18-3424	18-3207	18-3507	18-3324
50 (3 cyl)	D000750	G589999	18-8900	—	—	—	18-3445	—	—	—
50 (3 cyl)	G590000	& UP	18-3057	—	—	—	—	—	—	—
50 (4-stroke,Std)	G231123	& UP	18-3057	—	—	—	—	—	—	—
50 (4-stroke, 4 cyl.) 1.83:1 ratio	T178500	& UP	18-8900	—	—	—	18-3445	—	—	—
50 (4-stroke, 4 cyl.) 2.31:1 ratio	T178500	& UP	18-3056	—	—	—	—	18-3214	—	—
50 (EFI 4-stroke) 1.83:1 ratio	T409000	& UP	18-8900	—	—	—	18-3445	—	—	—
50 (EFI 4-stroke) 2.31:1 ratio	T409000	& UP	18-3056	—	—	—	—	18-3214	—	—
50 (4-stroke,Bigfoot)	G231123	& UP	18-3056	—	—	—	—	18-3214	—	—
55 (3 cyl)	D000750	& UP	18-8900	—	—	—	18-3445	—	—	—
60	6428681	D000749	18-3007	18-3107	18-3115	18-3118	18-3424	18-3207	18-3507	18-3324
60 Seapro	D000750	& UP	18-3056	18-3122	—	—	—	18-3214	—	—
60 Marathon	D000750	& UP	18-3056	18-3122	—	—	—	18-3214	—	—
60 Big Foot	D000750	& UP	18-3056	18-3122	—	—	—	18-3214	—	—
60 (3 cyl)	D000750	& UP	18-8900	—	—	—	—	—	—	—
60 (4 stroke, std.)	OT178500	& UP	18-8900	—	—	—	18-3445	18-3214	—	—
60 (4 stroke, Bigfoot)	OT178500	& UP	18-3056	—	—	—	—	18-3214	—	—
65( 4 cyl)	1542745	3293183	18-3017	18-3117	18-3114	—	—	18-3217	—	—
65(3 cyl)	3293184	4382056	18-3007	18-3107	18-3115	18-3118	18-3422	18-3207	18-3507	18-3322
65(3 cyl)	4382057	4571651	18-3007	18-3107	18-3115	18-3118	18-3424	18-3207	18-3507	18-3324
65 Jet	0D283222	& UP	18-3056	18-3122	—	—	—	18-3214	—	—
70	1413611	1566239	18-3017	18-3117	—	—	—	18-3217	—	—
70 (3 cyl)	4571652	4977156	18-3007	18-3107	18-3115	18-3118	18-3423	18-3207	18-3507	18-3323
70	4977157	B110053	18-3007	18-3107	18-3115	18-3118	18-3424	18-3207	18-3507	18-3324
70	B110054	& UP	18-3056	18-3124	—	—	—	18-3213	—	—

① For S/N 5206550 and UP .456 I.D. Only      ② .438 I.D. Only      ③ .456 I.D. Only  
 ④ Models with insulator on water pump housing bolts      ⑤ Models without insulator on water pump housing bolts

**OUTBOARD**

# MERCURY/MARINER

## Cooling System



### MERCURY COOLING SYSTEM APPLICATION

HP	Beginning Serial #	Ending Serial #	Impeller	Impeller Plate	Insert Cup	Upper Housing	Base	Impeller Repair Kit	Upper Kit	Complete Kit
75 (4 cyl)	6432901	& UP	18-3017	18-3117	18-3114	18-3116	18-3414	18-3217	18-3517	18-3314
75 (3 cyl)	A996142	C221999	18-3056	18-3124	—	—	—	18-3213	—	—
75 (3 cyl) ④	C222000	& UP	18-3056	18-3124	—	—	—	18-3213	—	—
75 (3 cyl) ⑤	C222000	& UP	18-3056	18-3122	—	—	—	18-3214	—	—
75 (4 stroke)	OG960500	& UP	18-3056	—	—	—	—	18-3214	—	—
80	1355468	3493912	18-3017	18-3117	—	—	—	18-3217	—	—
80 (4 cyl)	4831999	6432900	18-3017	18-3117	18-3114	18-3116	18-3414	18-3217	18-3517	18-3314
80 (3 cyl)	A996142	& UP	18-3056	18-3124	—	—	—	18-3213	—	—
80 Jet	0D28322	& UP	18-3056	18-3122	—	—	—	18-3214	—	—
85	1460999	4831998	18-3017	18-3117	—	—	—	18-3217	—	—
85 (4 cyl)	4590512	& UP	18-3017	18-3117	18-3114	18-3116	18-3414	18-3217	18-3517	18-3314
90	1766824	1869775	18-3017	18-3117	—	—	—	18-3217	—	—
90 (6 cyl)	4845301	& UP	18-3017	18-3117	18-3114	18-3116	18-3414	18-3217	18-3517	18-3314
90 (3 cyl)	B110054	C221999	18-3056	18-3124	—	—	—	18-3213	—	—
90 (3 cyl) ④	0A996142	& UP	18-3056	18-3124	—	—	—	18-3213	—	—
90 (3 cyl) ⑤	A0996142	& UP	18-3056	18-3122	—	—	—	18-3214	—	—
90 (4 stroke)	OG960500	& UP	18-3056	—	—	—	—	18-3214	—	—
95	1869776	2318585	18-3017	18-3117	—	—	—	18-3217	—	—
100 (6 cyl)	1464949	3253111	18-3017	18-3117	—	—	—	18-3217	—	—
100 (4 cyl) ④	B209468	& UP	18-3056	18-3124	—	—	—	18-3213	—	—
100 (4 cyl) ⑤	B209468	& UP	18-3056	18-3122	—	—	—	18-3214	—	—
105 Jet	0D182000	& UP	18-3017	18-3117	18-3114	18-3116	18-3419	18-3217	18-3517	18-3319
110	1870204	2314955	18-3017	18-3117	—	—	—	18-3217	—	—
115	2836019	& UP	18-3017	18-3117	—	—	—	18-3217	—	—
115 (6 cyl)	4694237	& UP	18-3017	18-3117	18-3114	18-3116	18-3414	18-3217	18-3517	18-3314
115 (4 cyl) ④	C100000	& UP	18-3056	18-3124	—	—	—	18-3213	—	—
115 (4 cyl) ⑤	B209468	& UP	18-3056	18-3122	—	—	—	18-3214	—	—
115 (4 stroke)	OT178500	& UP	18-3056	—	—	—	—	18-3214	—	—
125	2314956	3253111	18-3017	18-3117	—	—	—	18-3217	—	—
125 (4 cyl)	0D283222	& UP	18-3056	—	—	—	—	—	—	—
135	2839369	3293233	18-3017	18-3117	—	—	—	18-3217	—	—
V 135	904646	& UP	18-3017	18-3117	18-3114	18-3116	18-3419	18-3217	18-3517	18-3319
140	3293234	& UP	18-3017	18-3117	—	—	—	18-3217	—	—
140	4865678	& UP	18-3017	18-3117	18-3114	18-3116	18-3414	18-3217	18-3517	18-3314
140 Jet	0D082000	& UP	18-3017	18-3117	18-3114	18-3116	18-3419	18-3217	18-3517	18-3319
150	3502806	4121434	18-3017	18-3117	—	—	—	18-3217	—	—
150	4121435	4868647	18-3017	18-3117	18-3114	18-3116	18-3414	18-3217	18-3517	18-3314
V 150	A904646	& UP	18-3017	18-3117	18-3114	18-3116	18-3419	18-3217	18-3517	18-3319
V 150	A904645	& BELOW	18-3017	18-3117	18-3114	18-3116	18-3416	18-3217	18-3517	18-3316
V 175	6618751	& UP	18-3017	18-3117	18-3114	18-3116	18-3419	18-3217	18-3517	18-3319
V 175	6618750	& BELOW	18-3017	18-3117	18-3114	18-3116	18-3416	18-3217	18-3517	18-3316
V 200	6625221	& UP	18-3017	18-3117	18-3114	18-3116	18-3419	18-3217	18-3517	18-3319
V 200	6625220	& BELOW	18-3017	18-3117	18-3114	18-3116	18-3416	18-3217	18-3517	18-3316
V-200 DFI (3.0L)	OG386496	& UP	18-3056	—	—	—	—	18-3214	—	—
V 220	ALL		18-3017	18-3117	18-3114	18-3116	18-3419	18-3217	18-3517	18-3319
V 225	ALL		18-3017	18-3117	18-3114	18-3116	18-3416	18-3217	18-3517	18-3316
V-225 (3.0L) CARB & EFI	OD280813	& UP	18-3056	—	—	—	—	18-3214	—	—
V-225 DFI	OG590000	& UP	18-3056	—	—	—	—	18-3214	—	—
V-250 (3.0L) EFI	OG129222	& UP	18-3056	—	—	—	—	18-3214	—	—
XR4/Magnum II	ALL		18-3017	18-3117	18-3114	18-3116	18-3419	18-3217	18-3517	18-3319

① For S/N 5206550 and UP .456 I.D. Only  
④ Models with insulator on water pump housing bolts

② .438 I.D. Only  
⑤ Models without insulator on water pump housing bolts

③ .456 I.D. Only

OUTBOARD



### Features...

- ★ Exact replacement, high silicon content aluminum alloy with the same content and weight. Eliminates the need to replace all pistons unnecessarily. Replace only the piston(s) required for the repair.
- ★ Piston rings, bearings, wrist pins and circlips are all interchangeable with the OEM components. Makes repairs simpler, faster, and more economical.
- ★ Sierra pistons do not require additional piston to cylinder wall clearance like competitor's forged units. This allows Sierra pistons to use standard break-in and warm-up procedures, not long and complicated procedures like the competition.
- ★ No one warranties internal engine parts better than Sierra! That's because we're confident in our quality. Compare our quality, coverage and warranty to anyone and you will see why Sierra is the obvious choice for your next repair.

**ALL PISTONS  
ARE SUPPLIED COMPLETE WITH PISTON RINGS, WRIST PIN AND CIRCLIPS.**

**OUTBOARD**

