

CALL - 01722 711988

9-5.00 MON- FRIDAY

EMAIL

sales@moleroda.com

SHOP ONLINE 24/7 at

www.moleroda.com



**MOLERODA FINISHING SYSTEMS**

Manufacturers & Suppliers of Deburring & Finishing Tools

**EASY ORDERING**  
**FAST DELIVERY**

**OVER**  
**3000**  
**UNIQUE PRODUCTS**

OUR PARTNERS



**GRINDING, ABRASIVE &  
DEBURRING CONSUMABLES**



**POLISHING CONSUMABLES**



**COMPOUNDS, PASTES  
& SPRAYS**



**TOOLS & EQUIPMENT**



**MASS FINISHING**



**SAFETY & INSPECTION**



**Moleroda continues to see some big changes with an expanding sales team and new product ranges.**

Many thanks to all our existing and new customers who have supported us and continue to do so. We enjoy working with you to solve your finishing challenges.

Over the last few years we have been hitting the road and giving our customers the opportunity to try and test our huge variety of the very best equipment and consumables in finishing.

In partnership with Joke, we hosted a showcase called 'Innovations in Finishing.' Customers were able to see and try the latest in welding, micromotors, ultrasonic systems, cleaning, clamping, post processing and new consumable ranges... infact anything related to getting your desired finish was on show.

With the suces of Innovations in Finishing, we plan to take the showcase to many more areas in the UK. We hope to see you there.

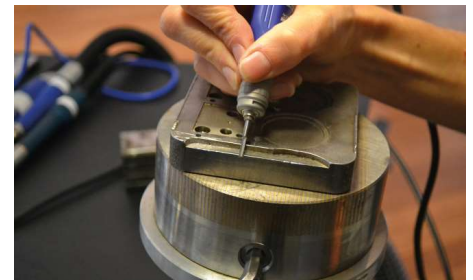
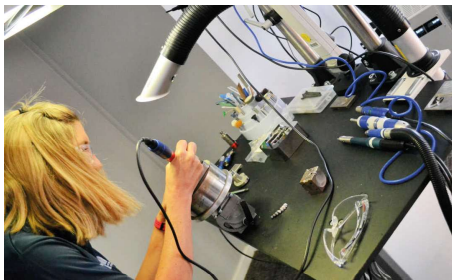

**Our RODA brand continues to grow and help our customers achieve 100% pass rates.** We are so proud of this range made in our UK factory.

The RODA range includes: RODA NyWheels, RODA NyMops, RODA Felt and RODA Points and each product consistently over-delivers on performance and efficiency. Look out for the RODA label and ask our team for information about the range.



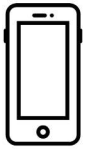

**CALL - +44 (0)1722 711 988**

Open: Mon- Fri 9am - 5.00pm

You can set up an account with us to order over the phone for fast and easy ordering and take advantage of a 30 day credit account. We ask new customers to pay via proforma for the first 3 orders. Our minimum order for telephone and email orders is £25 net, for smaller orders please refer to our website.



**EMAIL - [sales@moleroda.com](mailto:sales@moleroda.com)**

Haven't got time to chat? No problem! Send us over an email with your purchase order.

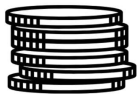

**WAYS TO PAY**

Call us with your card details or pay via BACS.



**ONLINE - [www.moleroda.com](http://www.moleroda.com)**

Browse our latest products and prices and order on line 24/7 from your desktop, mobile or tablet. And it doesn't stop there! Visit our site for tips, hints and product videos.

**Are you a jeweller? Visit our sister website - [www.polishingjewellery.co.uk](http://www.polishingjewellery.co.uk)**



**DELIVERY**

We always aim to dispatch same day if your item is in stock (ordered before 3pm). However, many of our products are made in our UK Wiltshire factory or bought to order so these will have a longer lead time. If you require something urgently, please call us to discuss.

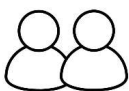

**FOR OUR LATEST NEWS, VISIT US ONLINE**



[www.youtube.com/moleroda](http://www.youtube.com/moleroda)



[www.facebook.com/moleroda](http://www.facebook.com/moleroda)



[www.twitter.com/moleroda](http://www.twitter.com/moleroda)



[www.instagram.com/molerodafinishingystems](http://www.instagram.com/molerodafinishingystems)





## GRINDING, ABRASIVE & DEBURRING CONSUMABLES

- P9-21 - GRINDING STONES
- P22-43 - GRINDING & HAND TOOLS
- P37-43 - MICROMESH KITS
- P44-85 - MOUNTED GRINDING TOOLS
- P86 - GRINDING BELTS
- P87-97 - GRINDING WHEELS



## POLISHING CONSUMABLES

- P100 - 107 - MOUNTED POLISHING TOOLS
- P108 - 116 - UNMOUNTED POLISHING TOOLS
- P117 - POLISHING HAND TOOLS



## COMPOUNDS, PASTES & SPRAYS

- P119-121 - PRECISION POLISHING
- P122-125 - GENERAL PURPOSE
- P126-132 - LEA, GRAINLOCK



## TOOLS & EQUIPMENT

- P134-138 - MICROMOTORS
- P139 - ULTRASONIC
- P140-146 - ROTARY TOOLS
- P146-150 - GRINDERS
- P152-153 - MANDRELS
- P151 - FINISHERS
- P165-168 - WELDING



## MASS FINISHING

- P168 - 171 - VIBRO FINISHING
- P172 - 173 - SHOT BLASTING
- P174 - MAGNETIC DEBURRING
- P175 - ULTRASONIC TANKS
- P176 - SURFACE TESTING



## SAFETY & INSPECTION

- P178 -179 - LIGHTING
- P180 - OPTIVISORS
- P181 - 182 - EXTRACTION
- P182 - 183 - WORKSHOP EQUIPMENT
- P184 - PPE



<b>A</b>			
3M polishing papers	117	Cotton bonded abrasive MX	69, 89
3M radial discs	84, 85	Cotton ring buffs	109
Abrasive belts	86	Cotton yarn mops, mounted	107
Abrasive Blasting Units	172-173	Cratex	75
Abrasive flap discs	96	Cross hole deburring	32-33
Abrasive flap wheels	61	Cut off wheels	94
Abrasive hand files	24-25		
Abrasive nylon filament wheels	73, 92	<b>D</b>	
Abrasive hand pads	36	Daylight lamp	179
Abrasive nylon roll	36	Deburring knives, ceramic	22
Abrasive Sanding Blocks	36	Deburring wheels	88
Abrasive string/tape	34	Dedeco	76-83
Aerosols	120	Degussit stones	18
Air engraver	154	Dental felts, mounted	104
Air Turbo lappers	160	Depressed centre dishes	93
Air filters/regulators	158	Diamond ceramic stones	20
Air recipricators	162	Diamond chisels / Dressers	52
Air tools	154-162	Diamond compound	119
Airflow mops	114	Diamond discs	63
Airway bias mops	92	Diamond foil	25
Algalox aluminium polishing paste	124	Diamond hand-e files	25
Aloxite grit	131	Diamond machine files	28
Angle grinder consumables	93-97	Diamond needle files	29
Antox pickling paste	122	Diamond point sets	52
Aprons	184	Diamond points	50-52
Artifex	89	Diamond riffler files	28
		Diamond slot wheels	51
		Diprofil recipricators	159-160
<b>B</b>		Dollie mops	114
Backing pads for angle grinders	95	Domed cup brushes	116
Belt files	24	Dotco Grinders	161
Belt sanders	151	Dressing sticks	16
Belt sticks	24	Dry sisal mops	113
Bench stones	18		
Bench polishers, hobby	148	<b>E</b>	
Bench polishers, industrial	149-150	Economy Roll, Aluminium Oxide	35
Bevelled-Edge wheels	109	Edenta polishing wheels	74
Bias Mops	92	Elastic polishing points	74
Biax deburring tools	162	End brushes	115
Blasting cabinets	172-173	ENESKA laser	165
Blow up tyre (pnumatic drum)	86	ENESKA new generation	134-135
Borazon	49	ENESKA post process	182
Brass Pencil	24	ENESKA recoat	163
Brass wheels	53, 87	ENESKA sonic	139
Bristle wheels	107, 116	Expanda wheels	86
Buff & blend, quick change	65	Extended grinding points	57
Buffing balls, mounted	72	Extraction (polishers)	181
<b>C</b>		<b>F</b>	
Calico mops, mounted	106	Felt bob kit	103-104
Carbide burrs	44-49	Felt buffing balls	106
Carbide Tools	48	Felt flap wheels	105
Cartridge rolls	62	Felt hand files	100
Ceramic knives	22	Felt lapping sticks, mounted	100
Ceramic stones	19-21	Felt rectangles	100
Cerium Oxide	123	Felt rollers	108
Chamois mops	115	Felt tapers	108
Chamois mops, mounted	106	Felt wheels	110
Cloth sheets	35	Felt wheels, mounted	105
Clover	120	Fibre backed sanding discs	95
Coloured mops	113	Filament wheels & brushes	92
Combination ring felts	109	File handles	27
Compound	126-130	Finger felts	109
Congress stones	9-17	Flapwheels	97

Flapwheels, mounted	61	Moleroda superchrome	120
Flex tools	146-147	Mop dresser	112
Flex-hones	33	Mops	112-115
Flexible shaft systems	140, 141, 143	Mould polishing stones sets	17
Flexifiles	23	Mould polishing stones	9-17
Flick wheels	53	Mould protection spray	120
Foredom	140	MX flexcut discs	93
		MX lapping sticks	16
		MX points & Wheels	69, 89, 93
<b>G</b>		<b>N</b>	
Glass beads	173	Needle Files, Vallorbe	26-27
Glass/ Brass Fibre	24	No1 slip joint handpieces	142
Gloves/ Gauntlets	184	NSK pneumatic system	156-157
Grainlock cold cement	131	Nylon finishing wheels	92
Grinding discs	94	Norton unitized points, wheels	68
Guards & Hoods	151		
		<b>O</b>	
<b>H</b>		Oil Stones	18
Hair wheels	53	Optivisor	180
Hand pads	36	Orbitool	33
		<b>P</b>	
<b>I</b>		Pendant motors	140-141
Impregnated nylon wheels	73	Pendant motor stands	142
Impulse air grinders	156	Penny wheels	116
Inspection lights	178	Pigtails	153
Interleaved flapwheels	97	Pink grinding points	54-55
		Plastibrade	132
<b>J</b>		Poli Mops, Arecal	95
Jewellers finishing wheels	92	Polishers & Linishers, industrial	149-151
Jiffy caps & mandrels	60	Polishing cloths	117
Jig & grinding pins	49	Polishing pastes	120, 124
		Protective clothing	184
<b>K</b>		Proxxon tools	138
Keyway wheels	97	Pumice	123
Knife edge wheels	105, 109		
		<b>Q</b>	
<b>L</b>		Quartz halogen lamps	178-179
Lacquer, Clear	122	Quick change discs	65
Lapping fluid	119	quick zip files & strips	25
Lapping Paste	121		
Lapping sticks	101	<b>R</b>	
Laser welding equipment	164-166	Radial weels	76-85
Lea compound	126-128, 130	Riffler files	30-31
Lights	178-179	Ring felts, mounted	109
Linishers	151	RODA Felt	102-103
Loosefold polishing mops, buffs	112	RODA MX	69
Loupe	180	RODA NyMop	90-91
Lubar, tallow/ bobbing grease	122	RODA NyWheel	70-71
		RODA Point	68-69
<b>M</b>		Rouge, compound	129
Magnifier Fluorescent Bench Lamps	178	Roughing stones	16
Mandrels	152	Rubber points/ wheels	74
Media, vibratory finishing	169		
Medimax	126	<b>S</b>	
Micro carbide burrs	46	Sanding discs	95, 154
Micro-Mesh - Rolls	37	Satene compound	130
Micro-Mesh - Pads	43	Scratch brushing wheels	87
Micro-Mesh - Flexifiles	23	Self adhesive disc holders	67
Micro-Mesh - Discs & belts	63	Self adhesive discs & rings	66-67, 110
Micro-Mesh - Compounds	124-125	SG6 Grinder	147
Micro-Mesh - Kits	38-43	Shotblasting	173
Micro-Mesh - Micromotor systems	136-138	Simichrome	124
Micropoints	57		
Mini stitched mops, mounted	107		
Mini superstones	20		

Solvent cleaner	120
Spinner	174
Sprabands	59
Split pin mandrels	152
Stitched mops	113
Stone holders	20-21
Surface testers	176
Suhner flexible shaft systems	145
Super lapping sticks	101
Sunburst	76-83
Surface conditioning discs	64-65
Superchrome polish	120
<b>T</b>	
Tapers	153
Truing stones	57
Tube brushes	32
Tube/ pipe sanders	144
Tungsten carbide coating kit	163
Twist in wire	32
Twist-N-Lok Discs	64
<b>U</b>	
Ultra fine ceramic stones	19
Ultralap	121
ultrasonic tanks & fluid	175
Unitized points & wheels	68-69
Unitized weldcut discs	93
Urawa micromotor systems	137
<b>V</b>	
Velcro disc holders	67
Velcro discs & rings	67
Vertex wheels	87
Vibratory finishing	169-171
Vices	183
Vienna lime	123
Vitrified mounted points	54-56
Vortex wheels & points	68
<b>W</b>	
Weld cleaning	163
Welding wires	166
Wet & dry economy roll	35
Wet & dry paper	35
Wheels, cups & pencils	107
White stitched mops	113
Wire wheel	53, 87
Wooden bobs & cones, mounted	101
Wooden handled brushes	36
Wooden lapping sticks, mounted	101
Wooden ring holder	109
Wool mops	115
Workshop equipment	182-184
<b>X</b>	
Xebec stones	19
Xebec cross hole deburring tools	58
xebec extended deburring tools	58
X-tra cut points	57



## SG6 VARIABLE SPEED STRAIGHT GRINDER

1600 W 1,600 - 4,800 rpm also comes with taper cone  
**Replacement for the EDX SG30.**  
**See page: 147**

SG6 STRAIGHT GRINDER	
110V OR 230V	✓
ORDER REF - SG6	



## RODA ABRASIVE HANDPADS



RODA Abrasive nylon scotch hand pads are used to give a satin/sateen finish most commonly on metal. Depending on the grade selected, different finishes can be achieved.  
Sold in packs of 10 (229 x 152mm)  
**See page: 36**

## RODA MX POINTS



We are excited to launch our very own brand new premium range of MX polishing points. This range will hold your material perfectly and offer a great finish on any metal. Unlike the rest of our RODA Point range – this new variation comes only in 125GFX.

Shapes available in:

MXB: BOB  
MXC: CONE  
MXT: TAPER

**See page: 69**



## SOLVENT SPRAY CLEANER



Powerful degreasing agent, works well against oil, grease, wax etc. Readily removes with minimum solvent wastage.

**Sold in 400ml Can or 5 Litre Drum**  
**See Page: 120**

### SOLVENT CLEANER

QUANTITY	
400ml can:	✓
5 ltr drum:	✓
ORDER REF - LF	

## RODA FELT

Over 30 years of experience and knowledge has been used to develop a quality product like no other. Designed and manufactured in the UK alongside polishing specialists.

**See page: 102-103**



## MOLERODA ULTRA LAPPING PASTE

Ultra Lapping Paste is an excellent quality abrasive paste compound made here in the UK. Polishing pastes are ideal for lapping and polishing hardened steels, chrome, soft non-ferrous metals and hard alloys.

**See page: 121**





## GRINDING, ABRASIVE & DEBURRING CONSUMABLES

- P9-21 - GRINDING STONES
- P22-43 - GRINDING & HAND TOOLS
- P37-43 - MICROMESH KITS
- P44-85 - MOUNTED GRINDING TOOLS
- P86 - GRINDING BELTS
- P87-97 - GRINDING WHEELS

## GRINDING ABRASIVES & DEBURRING

Grinding and Deburring is a critical part of the manufacturing process. In this section you will find the tools necessary for the initial surface preparation stages and burr removal. With any form of cutting or shaping, burrs will form to various degrees. Our range of grinding and deburring tools span from heavy duty cutting tools in the form of files and carbide burrs through to delicate micron level finishing with a full range of abrasive cloths and papers.

As well as traditional mould tool polishing stones we also offer ceramic stones which are extremely popular, particularly when paired with reciprocatory and ultrasonic systems found later in our tool section. You will also find files and ceramic deburring knives for hand finishing.

Moleroda carries a wide selection of mounted points starting coarse with carbide burrs, diamond points and vitrified points in a range of grades, through to finer more specialist MX points, ever popular Roda abrasive nylon, rubber points and radial discs. We can also offer the Xebec range of extended cross hole and bore deburring. We can advise on the right product for the material and application.

You will also find larger scale abrasives in this section including abrasive belts for finishing, large lap disc mops and flapwheels as well as angle grinder attachments in various materials.

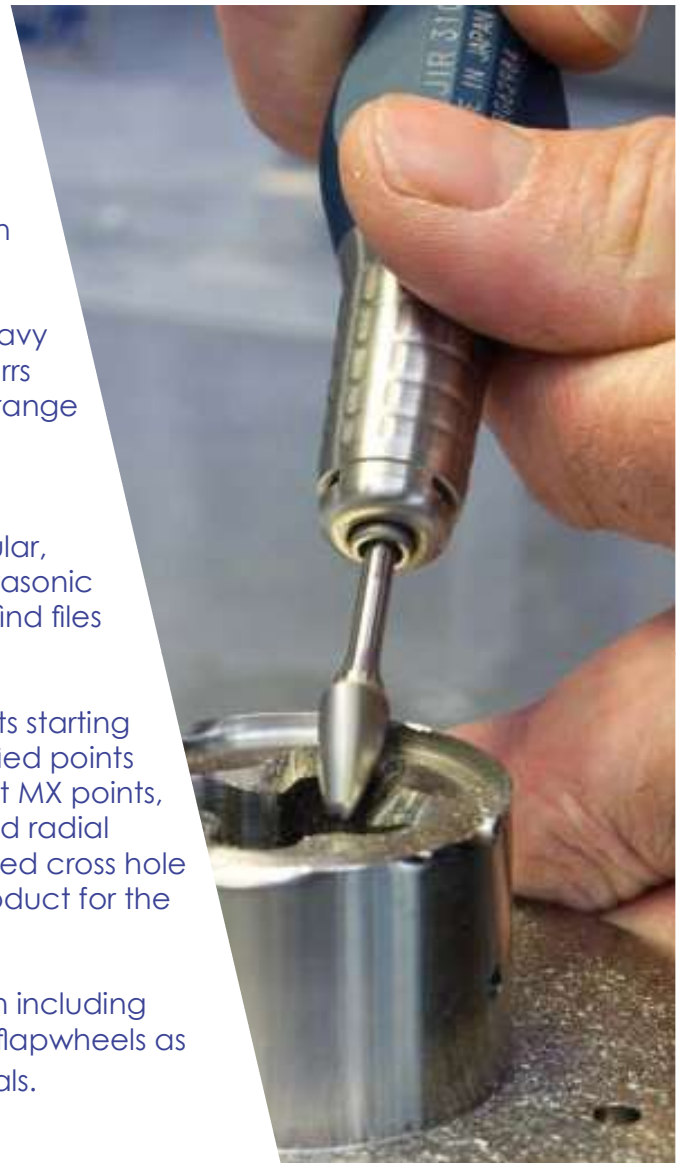

STONE	USES/CHARACTERISTICS	DESCRIPTION
<b>EDM</b>	A hard structured stone especially developed for the polishing of EDM machined surfaces. Breaks down slowly and retains shape. Excellent results on all hard tool steels.	Hard Aluminium Oxide, Colour: Orange Grits: 120, 180, 220, 320, 400, 600 Gesswein Equivalent: EDM
<b>Y2K</b>	New stone - alternative to EDM - with specialist additives to provide a fine, smooth finish. Harder, fast cutting, for intricate stoning work. Can be used dry or with stoning oil. Especially suitable for use in reciprocators and ultrasonic machines.	Semi-Hard Aluminium Oxide, Colour: Blue Grits: 120, 180, 220, 320, 400, 600
<b>Mould Master</b>	A tough stone with minimum bonding material. Permits fast cutting, breaks down slowly and evenly. Use on all hardened steels. Superb performance on EDM surfaces.	Hard Silicon Carbide, Colour: Dark Grey Grits: 80, 120, 150, 240, 320, 400, 600
<b>Res-Cut</b>	A hard resin-treated stone. 1/4 x 1/8" 220g and 320g are especially good for use in ultrasonic machines on EDM surfaces and all hardened steels. Good cutting stone, breaks down slowly. Load resistant. Can be used dry.	Hard Aluminium Oxide, Colour: Brown Grits: 120, 180, 220, 320, 400, 600
<b>R-Max</b>	A hard resin-bonded stone which holds its shape and maintains a sharp edge. Recommended for intricate finishing work. Works well with ultrasonic polishing.	Very Hard Aluminium Oxide, Colour: Green/Brown Grits: 90, 120, 180, 220, 320, 400, 600 Gesswein Equivalent: RA
<b>Ruby</b>	Sharp grains in a medium bond result in an aggressive cutting stone. Very good results and finish on all hard tool steels and exotic metals. Maintains shape, load resistant.	Sharp Aluminium Oxide, Colour: Pink Grits: 60, 80, 100, 120, 150, 220, 320
<b>YL-Oil</b>	Oil-filled to prevent loading. Very popular stone widely used for EDM scale removal. Good cutting with moderate breakdown. Can be used dry or with stoning oil.	Semi-Hard Aluminium Oxide, Colour: Ivory Grits: 100, 120, 150, 220, 320, 400, 600, 800 Gesswein Equivalent: OT
<b>Super</b>	A good general purpose mould polishing stone, made of premium aluminium oxide.	Semi-Hard Premium Aluminium Oxide, Colour: White Grits: 100, 120, 150, 220, 320, 400, 600
<b>Die*Star</b>	Very popular stone, excellent for all mould and die surface finishing. Fast cutting, load resistant stone, quickly conforms to contours.	Medium/Soft Aluminium Oxide, Colour: Tan/Green Grits: 100, 150, 220, 320, 400, 600, 900 Gesswein Equivalent: DF
<b>Regular</b>	Made from premium green silicon carbide grain. Fast cutting with a medium break down rate. For general mould and die polishing on all tool steels. Breaks down evenly and retains shape.	Medium Silicon Carbide, Colour: Grey/Green Grits: 80, 120, 150, 240, 320, 400, 600, 800 Gesswein Equivalent: MF
<b>Flex</b>	Resilient resin-bonded stone. Extremely snap-resistant, particularly in small sizes. Recommended as a finishing stone as resin bond produces high lustre finish. Especially good for slots, ribs and other intricate shapes.	Hard Aluminium Oxide, Colour: Grey/Brown Grits: 150, 240, 320, 400, 600,
<b>Superfine</b>	An accurately graded fine grit stone. Soft bonded with rapid breakdown for final finishing work.	Soft Aluminium Oxide, Colour: White Grits: 400, 600, 800, 900, 1000, 1200
<b>LA</b>	A soft stone made of very fine grit (1000+) levigated alumina. Excellent for final surface preparation before diamond finishing.	Levigated Alumina, Colour: White
<b>Extra Soft</b>	Exhibits rapid breakdown and quickly forms to a contour. Primarily for use on unhardened steels and non-ferrous material. Fast cutting.	Soft Silicon Carbide, Colour: Grey Grits: 80, 120, 150, 240, 320, 400, 600
<b>Super Soft</b>	A very soft bonded stone with a non-loading, rapid breakdown. Recommended for aluminium, stainless steel and other softer non-ferrous metals. Fast cutting.	Soft Aluminium Oxide, Colour: White Grits: 80, 120, 150, 180, 220, 320

Hardest to Softest

GRINDING



## EDM

### Hard Aluminium Oxide

All 1/16'' stones are 6'' long except 5/32'' sq. and 1/8'' sq. stones, which are 4'' long. Other sizes and grits are available to order.

Some Boride and Gesswein stones can also be supplied.

These hard structured stones are especially developed for the polishing of EDM machined surfaces.

- Breaks down slowly and retains shape.
- Excellent results on all hard tool steels.

### Orange/Brown Boxed per 12

(Half Boxes Available)



GRINDING

EDM						
Size (")	AVAILABLE GRITS					
	120	180	220	320	400	600
<b>RECTANGULAR</b>						
1/4 x 1/16	✓	✓	✓	✓	✓	✓
1/4 x 1/8	✓	✓	✓	✓	✓	✓
1/2 x 1/16	✓	✓	✓	✓	✓	✓
1/2 x 1/8	✓	✓	✓	✓	✓	✓
1/2 x 1/4	✓	✓	✓	✓	✓	✓
3/4 x 1/4	X	✓	X	X	X	X
1 x 1/8	X	✓	X	✓	✓	✓
1 x 1/4	X	X	✓	✓	X	X
1 x 1/2	✓	✓	X	✓	X	X
<b>SQUARE</b>						
1/8 sq.	✓	✓	✓	✓	✓	✓
5/32 sq.	✓	✓	✓	✓	✓	✓
1/4 sq.	✓	✓	✓	✓	✓	✓
3/8 sq.	✓	✓	✓	✓	✓	✓
1/2 sq.	✓	✓	✓	✓	✓	X
1 sq.	✓	X	X	X	X	X
<b>TRIANGULAR</b>						
1/4 tri.	✓	✓	✓	✓	✓	✓
3/8 tri.	✓	✓	✓	✓	✓	✓
1/2 tri.	X	✓	✓	✓	✓	X
<b>ROUND</b>						
5/32 dia.	✓	✓	X	✓	✓	X
1/4 dia.	✓	✓	✓	✓	✓	X
3/8 dia.	✓	✓	✓	✓	X	X
1/2 dia.	X	✓	X	✓	X	X
<b>HALF ROUND</b>						
3/8 dia.	X	X	✓	✓	✓	X
1/2 dia.	X	X	X	✓	X	X
<b>ORDER REF - EDM(SIZE &amp; GRIT)</b>						

## DIE\*STAR

### Medium/Soft Aluminium Oxide

Very popular stone, excellent for all mould and die surface finishing.

Fast cutting, load resistant stone, quickly conforms to contours.

### Grey

Boxed per 12. (Half Boxes Available)



GRINDING

DIE STAR									
Size (")	AVAILABLE GRITS								
	100	150	180	220	320	400	500	600	900
<b>RECTANGULAR</b>									
1/4 x 1/16	X	X	✓	✓	✓	✓	X	X	X
1/4 x 1/8	✓	✓	✓	✓	✓	✓	✓	✓	X
1/2 x 1/16	✓	✓	✓	✓	✓	✓	✓	✓	X
1/2 x 1/8	✓	✓	✓	✓	✓	✓	✓	✓	✓
1/2 x 1/4	✓	✓	✓	✓	✓	✓	✓	✓	✓
3/4 x 1/2	✓	✓	✓	✓	X	X	X	X	X
1 x 1/8	X	X	✓	X	✓	X	X	X	X
1 x 1/4	X	✓	✓	✓	✓	✓	✓	✓	✓
1 x 1/2	✓	✓	✓	✓	✓	✓	✓	✓	X
1 x 3/4	X	X	✓	X	X	X	X	X	X
1.1/4 x 1/4	X	X	X	X	✓	✓	✓	✓	X
<b>SQUARE</b>									
1/8 sq.	X	✓	✓	✓	✓	✓	✓	✓	X
5/32 sq.	X	✓	✓	✓	✓	✓	✓	✓	X
1/4 sq.	✓	✓	✓	✓	✓	✓	✓	✓	✓
3/8 sq.	X	✓	✓	✓	✓	✓	X	✓	X
1/2 sq.	X	✓	✓	✓	✓	✓	✓	✓	X
<b>TRIANGULAR</b>									
1/4 tri.	✓	X	✓	X	✓	X	X	X	X
3/8 tri.	X	X	X	✓	✓	X	X	X	X
1/2 tri.	X	X	X	X	X	✓	X	✓	✓
<b>ROUND</b>									
5/32 dia.	X	X	X	X	X	X	X	✓	X
1/4 dia.	X	✓	✓	✓	✓	✓	X	✓	X
3/8 dia.	X	X	X	✓	✓	✓	X	✓	X
1/2 dia.	X	X	X	X	X	X	X	X	X
<b>HALF ROUND</b>									
1/2 dia.	X	X	X	✓	X	X	X	X	X

ORDER REF - DS(SIZE & GRIT)

## MOULDMASTER Hard Silicon Carbide

A tough stone with minimum bonding material. Permits fast cutting, breaks down slowly and evenly. Use on all hardened steels. Superb performance on EDM surfaces.

**Blue/Grey**  
**Boxed Per 12.**



MOULDMASTER							
Size ("")	AVAILABLE GRITS						
	80	120	150	240	320	400	600
RECTANGULAR							
1/4 x 1/16	X	✓	✓	✓	✓	✓	X
1/4 x 1/8	X	✓	✓	✓	✓	✓	✓
1/2 x 1/16	X	✓	✓	✓	✓	✓	X
1/2 x 1/8	X	✓	✓	✓	✓	✓	✓
1/2 x 1/4	✓	✓	✓	✓	✓	✓	✓
SQUARE							
5/32 sq.	X	✓	✓	✓	✓	✓	✓
1/4 sq.	✓	✓	✓	✓	✓	✓	✓
1/2 sq.	X	X	✓	✓	✓	✓	✓
ORDER REF - MM(SIZE & GRIT)							

## YL-OIL Semi-Hard Aluminium Oxide

Oil-filled to prevent loading. Very popular stone widely used for EDM scale removal. Good cutting and moderate break down. Can be used dry or with stoning oil.

**Yellow**  
**Boxed Per 12.**



YL OIL							
Size ("")	AVAILABLE GRITS						
	120	150	220	320	400	600	800
RECTANGULAR							
1/4 x 1/16	X	✓	X	✓	✓	X	X
1/4 x 1/8	✓	✓	✓	✓	✓	✓	✓
1/2 x 1/16	✓	✓	X	✓	✓	✓	✓
1/2 x 1/8	✓	✓	✓	✓	✓	✓	✓
1/2 x 1/4	✓	✓	✓	✓	✓	✓	✓
3/4 x 3/8	X	X	X	X	✓	✓	X
3/4 x 1/2	X	X	X	✓	✓	✓	X
SQUARE							
5/32 sq.	✓	✓	✓	✓	✓	✓	✓
1/4 sq.	✓	✓	✓	✓	✓	✓	✓
1/2 sq.	X	X	X	✓	X	X	X
1 sq.	X	X	✓	✓	X	X	X
ORDER REF - YL(SIZE & GRIT)							

## EXTRA-SOFT Soft Silicon Carbide

Exhibits rapid breakdown and quickly forms to a contour. Primarily used on unhardened steels and non-ferrous material. Fast cutting.

**Dark Grey**  
**Boxed Per 12.**



X-SOFT							
Size ("")	AVAILABLE GRITS						
	80	120	240	320	400	600	800
RECTANGULAR							
1/2 x 1/8	X	✓	✓	✓	✓	✓	✓
1/2 x 1/4	✓	✓	✓	✓	✓	✓	✓
SQUARE							
5/32 sq.	X	✓	X	X	X	X	X
ORDER REF - ES(SIZE & GRIT)							



## R-MAX

### Very Hard Aluminium Oxide

A hard resin-bonded stone which holds its shape and a sharp edge. Recommended for intricate finishing work. Works well for ultrasonic polishing.

**Brown**

**Boxed Per 12.**



R-MAX								
Size (")	AVAILABLE GRITS							
	90	120	180	220	280	320	400	600
<b>RECTANGULAR</b>								
1/4 x 1/16	X	X	X	X	✓	✓	✓	X
1/4 x 1/8	X	✓	✓	✓	✓	✓	✓	✓
1/2 x 1/16	X	✓	✓	✓	✓	✓	✓	X
1/2 x 1/8	X	X	✓	✓	✓	✓	X	X
1/2 x 1/4	✓	✓	✓	✓	✓	✓	✓	✓
<b>SQUARE</b>								
1/8 sq.	X	X	✓	X	✓	X	X	X
5/32 sq.	X	X	X	✓	✓	✓	✓	✓
1/4 sq.	✓	✓	✓	✓	✓	✓	✓	✓
<b>ROUND</b>								
5/32 dia.	X	X	X	✓	✓	✓	✓	✓
<b>ORDER REF - RM(SIZE &amp; GRIT)</b>								

GRINDING

## REGULAR

### Medium Silicon Carbide

Made from premium green silicon carbide grain. Fast cutting with a medium breakdown rate. For general mould and die polishing on all tool steels. Breaks down evenly and retains shape.

**Green/Grey**

**Boxed Per 12.**



REGULAR										
Size (")	AVAILABLE GRITS									
	80	120	150	180	240	320	400	500	600	800
<b>RECTANGULAR</b>										
1/4 x 1/8	X	X	✓	X	X	✓	X	X	X	X
1/2 x 1/16	X	X	X	X	X	✓	X	X	X	X
1/2 x 1/8	✓	✓	✓	✓	✓	✓	✓	X	X	X
1/2 x 1/4	✓	✓	✓	✓	✓	✓	✓	✓	✓	✓
3/4 x 1/4	X	X	✓	X	X	X	X	X	X	X
3/4 x 1/2	X	✓	✓	X	✓	✓	X	✓	X	X
1 x 1/2	X	✓	X	X	✓	✓	X	✓	X	X
1 x 1.1/2	X	X	X	X	X	✓	X	X	X	X
<b>SQUARE</b>										
1/4 sq.	X	✓	✓	✓	✓	✓	✓	✓	✓	✓
3/8 sq.	X	X	✓	X	X	X	✓	X	X	X
1/2 sq.	X	X	✓	✓	✓	✓	✓	X	X	X
1 sq.	X	X	✓	X	X	X	X	X	X	X
<b>ORDER REF - REG(SIZE &amp; GRIT)</b>										

## RUBY

### Medium Sharp Aluminium Oxide

Sharp grains in a medium bond result in an aggressive cutting stone. Very good results and finish on all hard tool steels and exotic metals. Maintains shape, load resistant.

**Pink**

**Boxed Per 12.**



RUBY							
Size (")	AVAILABLE GRITS						
	60	80	100	120	150	220	320
<b>RECTANGULAR</b>							
1/4 x 1/16	X	X	X	✓	✓	✓	✓
1/4 x 1/8	X	X	✓	✓	✓	✓	✓
1/2 x 1/16	X	X	X	✓	✓	✓	✓
1/2 x 1/8	X	X	✓	✓	✓	✓	✓
1/2 x 1/4	✓	X	✓	✓	✓	✓	✓
1 x 1/2	X	X	X	✓	X	X	X
<b>SQUARE</b>							
5/32 sq.	X	X	X	X	X	✓	X
1/4 sq.	✓	✓	✓	✓	✓	✓	✓
<b>ORDER REF - RU(SIZE &amp; GRIT)</b>							

GRINDING

## SUPERSOFT

### Soft Aluminium Oxide

A very soft bonded stone with a non-loading, rapid breakdown. Recommended for aluminium, stainless steel and other softer non-ferrous metals. Fast cutting.

**White**

**Boxed Per 12.**



SUPERSOFT						
Size (")	AVAILABLE GRITS					
	80	120	150	180	220	320
<b>RECTANGULAR</b>						
1/2 x 1/8	X	X	X	X	✓	X
1/2 x 1/4	✓	✓	✓	✓	✓	✓
<b>SQUARE</b>						
1/4 sq.	X	✓	✓	X	✓	X
<b>ROUND</b>						
1/4 dia.	✓	X	✓	X	X	✓
<b>ORDER REF - SS(SIZE &amp; GRIT)</b>						

## SUPER

### Semi-Hard Premium Aluminium Oxide

A good general purpose mould polishing stone, made from premium grade aluminium oxide.

**White**

**Boxed Per 12.**



SUPER				
Size (")	AVAILABLE GRITS			
	150	220	320	400
<b>RECTANGULAR</b>				
1/2 x 1/16	X	✓	X	✓
1/2 x 1/8	X	✓	X	✓
1/2 x 1/4	✓	✓	✓	✓
<b>SQUARE</b>				
5/32 sq.	X	✓	X	X
1/4 sq.	X	✓	✓	X
<b>ORDER REF - SU(SIZE &amp; GRIT)</b>				



**HOLDERS ON  
PAGE 29**

## FLEX

### Hard Aluminium Oxide

Extremely snap-resistant. Recommended as a finishing stone as the resin bond produces a high lustre finish. Especially good for slots, ribs and other intricate shapes.

**Grey/Brown**

**Boxed Per 12.**

FLEX				
Size (")	AVAILABLE GRITS			
	150	240	320	400
<b>RECTANGULAR</b>				
1/4 x 1/16	✓	✓	✓	X
1/4 x 1/8	✓	✓	✓	X
1/2 x 1/16	✓	✓	✓	X
1/2 x 1/8	✓	✓	✓	X
1/2 x 1/4	X	X	X	✓

ORDER REF - FL(SIZE & GRIT)



## RES-CUT

### Hard - Aluminium Oxide

A hard resin-treated stone. 1/4" x 1/8" 220g and 320g are especially good for use in ultrasonic machines, on EDM surfaces and all hardened steels. Good cutting stone, breaks down slowly.

**Brown**

**Boxed Per 12.**



RES-CUT						
Size (")	AVAILABLE GRITS					
	150	180	220	320	500	600
<b>RECTANGULAR</b>						
1/4 x 1/8	X	X	✓	✓	X	X
1/2 x 1/4	✓	✓	✓	✓	X	X
<b>SQUARE</b>						
5/32 sq.	X	X	X	X	X	✓
1/4 sq.	X	X	✓	✓	✓	X

ORDER REF - RC(SIZE & GRIT)

GRINDING

## SUPERFINE

### Soft Aluminium Oxide

An accurately graded fine grit stone. Soft bonded with rapid breakdown for final finish work.

**White**

**Boxed Per 12.**



SUPERFINE						
Size (")	AVAILABLE GRITS					
	400	600	800	900	1000	1200
<b>RECTANGULAR</b>						
1/4 x 1/16	X	X	X	✓	X	X
1/4 x 1/8	X	✓	✓	✓	✓	✓
1/2 x 1/8	X	✓	✓	✓	✓	✓
1/2 x 1/4	✓	✓	✓	✓	✓	✓
<b>SQUARE</b>						
1/4 sq.	✓	✓	✓	✓	✓	✓

ORDER REF - SF(SIZE & GRIT)

## LA

### Levigated Alumina (1000+ grit)

A soft stone made of very fine grit. Excellent for final surface preparation before diamond finishing.

**White**

**Boxed Per 12.**

LA (LEVIGATED ALUMINA)	
Size (")	
<b>RECTANGULAR</b>	
1/4 x 1/8	✓
<b>SQUARE</b>	
1/4 sq	✓

ORDER REF - LA(SIZE & GRIT)



## Y2K

### Blue EDM - Hard Aluminium Oxide

New stone - alternative to EDM - with special additives to provide a fine, smooth finish. Harder, fast cutting, for intricate stoning work. Can be used dry or with stoning oil. Especially suitable for use in reciprocators and ultrasonic machines.

**Blue**

**Boxed Per 12.**



Y2K					
Size (")	AVAILABLE GRITS				
	120	180	220	320	400
<b>RECTANGULAR</b>					
1/4 x 1/8	✓	✓	✓	✓	X
1/2 X 1/16	✓	✓	X	✓	X
1/2 x 1/4	✓	✓	✓	✓	X
<b>SQUARE</b>					
5/32 sq.	X	✓	X	✓	✓

**ORDER REF - Y2K(SIZE & GRIT)**

## Arkansas Stones

Selected quality, Hard Arkansas stones for use with oil.

- Genuine USA origin.
- Clean, sharp edges.
- Free from defects
- Superfine grade



GRINDING

## ROUGHING STONES

For large cavities  
Aluminium oxide  
A rapid working stone for stock removal and flattening large areas.



ROUGHING STONES		
Size (")		Grits Available
1 x 1/2 x 6"	✓	80, 120
1 x 1/2 x 8"	✓	180 & 220
11/2 X 2 X 8"	✓	80 & 120

**ORDER REF - RS**

## DRESSING STICKS

Used for shaping and cleaning mounted points and grinding wheels.



DRESSING STONES			
Size	Ref.		ORDER REF
<b>GENERAL PURPOSE DRESSING STICKS</b>			
25 x 25 x 150mm	C24/30 - Q - VDW	✓	DSGP
<b>DIAMOND WHEEL DRESSING STICKS</b>			
13 x 13 x 100mm	38A-2201VBE	✓	DSD
20 x 20 x 150mm	38A-2201VBE	✓	

## MX LAPPING STICKS

MX honing sticks are long lasting, strong and slow to load. They work on many metals and alloys: Stainless Steel, Steel, Aluminium and others.

**Note** - Grits give a finer finish than coated or resinoid abrasives i.e 36 grit gives approximately an 80 grit finish.



MX STICKS			
ORDER REF	SIZE (mm)	80g/120g/180g	220g/320g
MX146S	6 sq x 150	✓	✓
MX386S	10 sq x 150	✓	✓
MX126S	12 sq x 150	✓	✓
MX346S	20 sq x 150	✓	✓
MX16S	25 sq x 150	✓	✓
MX144R	6 dia x 100	✓	✓
MX384R	10 dia x 100	✓	✓
MX124R	12 dia x 100	✓	✓

**Specify grit required: 80 120 180 220 320**

**Round sticks can be supplied 150mm long subject to minimum order quantities and availability**



## PENCIL STONE SET NO.36

This assortment consists of 36 pieces 5/32'' sq. x 4'' long pencil stones. Included are 6 of each

- Regular
- YL-oil
- EDM
- Ruby
- Super
- Mouldmaster

All in a variety of grits.



SET NO.36



ORDER REF - PSS36

## PENCIL STONE SET NO.12

This assortment consists of one of each of the following 5/32'' sq. x 4'' long pencil stones:

- EDM -120g, 220g, 400g
- Die\*Star - 220g, 320g, 400g
- Mouldmaster - 150g, 320g
- YL-Oil - 220g, 400g
- R-Max - 400g
- R-Max 5/32'' dia. - 320g



SET NO.12



ORDER REF - PSS12

## POLISHING STONE SET NO.72

This assortment consists of 72 pieces in various sizes, covering all of the 10 grades of Mould and Diemaker polishing stones. Included are coarse (100g) stones up to superfine (1200g) Finishing stones.



SET NO.72



ORDER REF - PSS72

## PENCIL STONE SET NO.14

This assortment consists of 14 pieces 1/4 x 1/2 x 6'' long in the following grades:

- EDM -120g, 180g, 320g
- Die\*Star - 220g, 320g, 400g
- Mouldmaster - 150g, 320g
- YL-Oil - 400g
- Ruby - 220g
- Superfine - 900g
- Regular - 400g
- Also - 2 MX Finishing Sticks



SET NO.14



ORDER REF - PSS14

\*Kit contents may vary slightly from that pictured



BENCHSTONES			
ORDER REF	SIZE (mm)	GRADE	
<b>SQUARE FILES</b>			
F14	100 x 6	C/M/F	✓
F34	100 x 10	C/M/F	✓
F44	100 x 13	C/M/F	✓
<b>ROUND FILES</b>			
F214	100 x 6	C/M/F	✓
F234	100 x 10	M/F	✓
F244	100 x 13	M/F	✓
<b>HALF-ROUND FILES</b>			
F344	100 x 13	M/F	✓
<b>TRIANGULAR FILES</b>			
F114	100 x 6	C/M/F	✓
F134	100 x 10	C/M/F	✓
F144	100 x 13	C/M/F	✓

BENCHSTONES			
ORDER REF	SIZE (mm)	GRADE	
<b>ROUND EDGE SLIP</b>			
S14	100 x 25 x 11 x 5	M/F	✓
S24	115 x 45 x 6 x 1.5	M/F	✓
S44	115 x 45 x 13 x 5	M/F	✓
<b>SILVERSMITHS STONE</b>			
F444	100 x 13 x 1.5	M/F	✓
<b>BENCH STONES</b>			
B24	100 x 25 x 13	C/M/F	✓
B6	150 x 50 x 25	C/M/F	✓
B8	200 x 50 x 25	C/M/F	✓
<b>COMBINATION STONES</b>			
IB24	100 x 25 x 13	F	✓
IB6	150 x 50 x 25	F	✓
IB8	200 x 50 x 25	F	✓

GRINDING



**BENCH/OIL STONES**

**COMBINATION STONES**



## DEGUSSIT STONES

Degussit fine grinding tools are bond-free and have great hardness, high wear resistance, excellent shape stability and outstanding surface finish. Especially good on hard materials - popular in watch making.







DEGUSSIT SET NO.420	
Set	✓
ORDER REF - DEG420	

## DEGUSSIT STONE SET NO.420

This set includes:

- 11 stones, one of each of all sizes
- 1 double ended holder
- 2 additional stone collets



DEGUSSIT STONES					
ORDER REF	SHAPE		REF	SIZE (mm)	
DEGS	Square		400	1 x 50	✓
			403	2 x 100	✓
DEGTRI	Triangle		402	2 x 50	✓
			413	3 x 100	✓
DEGR	Round		401	1 x 50	✓
			404	2 x 100	✓
			405	3 x 100	✓
DEGF	Flat		406	0.3 x 3 x 50	✓
DEGHR	Half-Round		407	4 x 100	✓
DEGB	Barrette		409	1.5 x 5 x 100	✓
DEGC	Crossing		411	1.5 x 4 x 100	✓
DEGSPARE HOLDER	Spare Stone Holder				✓

**CERAMIC STONES**

A fine grit finishing stone made of new composite material of ceramic fibres in a very hard thermoset resin. Very effective for ultrasonic polishing and in reciprocating tools. Virtually unbreakable – Can be accurately dressed – Long-lasting - Maintains shape.



GRITS & COLOURS
XEBEC
120g Purple/Green
220g Dark Brown
300g Light Brown
400g Orange
600g Black
800g Blue
1000g White
1200g Red
1500g Yellow
2000g Cream
3000g Pink

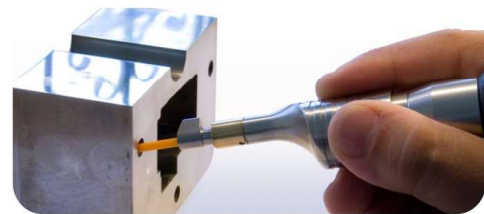

**ROUND CERAMIC STONES**

Round ceramic stones bridge the gap between hand stoning and ultrasonic polishing. They fit straight into a rotary collet. The stones are easily shaped when run against a diamond file to a point.



ROUND CERAMIC STONES		
STONE SIZE (mm)		HOLDER TO SUIT
1.6 dia x 50	✓	FIT INTO THE SAME SIZE COLLET
2.35 dia x 50	✓	
3 dia x 50	✓	
3 dia x 100	✓	
3 dia x 150	✓	

ORDER REF - UFC

**STONE HOLDERS**

To suit both hand stoning and machine stoning with reciprocators.



Set CH3 Contains - CH4, CH6, CH10  
Set CSH3 Contains - CSH6, CSH10, CSH36

ULTRA FINE CERAMIC STONES			
XEBEC & REGULAR	ALL GRITS	HOLDERS TO SUIT	
STONE SIZE (mm)		HAND	MACHINE
0.5 x 2 x 100	✓	CH2	X
0.5 x 4 x 100	✓	CH4	CSH4
0.5 x 6 x 100	✓	CH6	CSH6
1 x 2 x 100	✓	CH2	X
1 x 4 x 100	✓	CH4	CSH4
1 x 6 x 100	✓	CH6	CSH6
1 x 10 x 100	✓	CH10	CSH10
1 x 4 x 150	✓	CH4	CSH4
1 x 6 x 150	✓	CH6	CSH6
1.5 x 4 x 100	✓	CH4	CSH4
1.5 x 6 x 100	✓	CH6	CSH6
1.5 x 10 x 100	✓	CH10	CSH10
3 x 6 x 100	✓	X	CSH36

ORDER REF - UFC

CERAMIC STONE HOLDERS			
HAND HOLDERS		MACHINE HOLDERS	
CH2	✓	X	
CH4	✓	CSH6*	
CH6		CSH10*	✓
CH10		CSH36	
CH3 (set 3)	✓	CSH3 (set 3)*	

ORDER REF - UFC-H(No)      ORDER REF - NSKSH

**GRINDING**

## MINI SUPER STONES

The pencil like holders for the mini super stones allow easy manipulation of the ceramic stones into small and intricate areas for polishing.

The stones are very strong and long lasting, making them a very effective way of desparking and deburring.

### Sold per Stone or Holder



MINI SUPER STONES		
<b>Mini Super Stones SMALL</b>	<b>Size</b>	
Holder	S Type	
S Yellow 180	0.5 x 0.5 x 50 mm	✓
S Light Brown 300		
S Blue 800		
S Red 1200		
<b>Mini Super Stones MEDIUM</b>	<b>Size</b>	
Holder	M Type	
M Yellow 180	0.9 x 0.9 x 50 mm	✓
M Light Brown 300		
M Blue 800		
M Red 1200		
<b>Mini Super Stones LARGE</b>	<b>Size</b>	
Holder	L Type	
L Yellow 180	1.4 x 1.4 x 50 mm	✓
L Light Brown 300		
L Blue 800		
L Red 1200		
ORDER REF - UFCM		

GRINDING

## MINI SUPER STONES

### Grits-

- Yellow 180g
- Light Brown 300g
- Blue 800g
- Red 1200g



MINI SUPER STONE SETS		
EACH		
Mini Super Stone Set S	Set consists of one holder, one light brown, two blue & one red stone.	✓
Mini Super Stone Set M		✓
Mini Super Stone Set L		✓
ORDER REF - UFCMSS		

## DIAMOND CERAMIC STONES

The diamond allows cutting both on the ends and also the sides of the stone which the standard ceramic stones do not. These stones are excellent for slots where the sides of the slot are easily polished. The diamond is mixed into the ceramic fibres, giving a fine and even stroke pattern with excellent stock removal.

The new 200 grit offers faster cutting and quicker removal of sparking.



DIAMOND CERAMIC STONES					
GRADE (Colour)	1x2x100mm	1x4x100mm	1x6x100mm	1x10x100mm	3 dia x 50mm
D200 (Black)	✓	✓	✓	✓	✓
D400 (Grey)	✓	✓	✓	✓	✓
D600 (Green)	✓	✓	✓	✓	✓
ORDER REF - UFCD					

HAND-HELD STONE HOLDERS		
ORDER REF	DESCRIPTION	
<b>H-10</b>	Most versatile stone holder taking stones up to 1/2 x 1/8". Double-ended, light weight wear-resistant nylon.	✓
<b>H-12</b>	As the H-10 above, but one end takes stones 1/2 x 1/4" and the other end takes stones 1/4" square or 1/4" round.	✓
<b>H-20</b>	Round, double-ended stone holder features screw-on collars to hold stones securely. Holds all shapes up to 1/4" thick.	✓
<b>H-30</b>	Pencil stone holder for 5/32" square stones. Push-button release provides for quick stone change or adjustment.	✓
	REPLACEMENT COLLET FOR H-30	✓
<b>H-112</b>	Light weight aluminium holder. Holds stones measuring 1 x 1/2", 3/4 x 1/2", 1/2 x 1/4", 1/2 x 1/8"	✓
<b>NFH-FH40</b>	Holds 1/8" square and 5/32" round stones. Also takes 405,407,409,411 & 413 Ruby Degussit stones. Push-button release.	✓



**H10 & H12**



**H-20**

GRINDING

## HAND HELD STONE HOLDERS

Holders to suit polishing stones and lapping sticks.



**H-30**



**H-112**



**FH-40**

## RECIPROCATOR STONE HOLDERS

Holders to suit polishing stones and lapping sticks for use with reciprocators.



**H-101 & 102**



**H-401**



**H-666**

STONE HOLDERS TO FIT RECIPROCATORS		
ORDER REF	DESCRIPTION	
<b>H-101</b>	Takes stones 1/4 x 1/16", 1/4 x 1/8", 1/2 x 1/16" & 5/32" square. Shank diameter 1/8".	✓
<b>H-102</b>	Takes stones 1/2 x 1/8", 1/4" square, 1/4" round & 1/4" triangle. Shank diameter 1/8".	✓
<b>H-401</b>	Light weight reinforced nylon vice-clamp holder for stones up to 1/2" thick. Shank diameter 1/8".	✓
<b>H-666</b>	Small-sized, light weight stone holder. For stones up to 1/4 x 1/2" thick. Shank diameter 3mm.	✓
<b>H-667</b>	Very strong holder. Takes stones 1/2 x 1/4", 1/2 x 1/8". Shank diameter 3mm.	✓
<b>H-VEA</b>	Heavy duty metal holder for most stones up to 10mm sq or 13mm diameter. Shank diameter 3mm, with adjustable angle.	✓
<b>H-D</b>	Medium duty, plastic holder. For stones up to 10mm sq or 13mm diameter. Shank diameter 3mm, with adjustable angle.	✓



**H-667**



**H-VEA**



**H-D**



# SPECIALIST DEBURRING TOOLS



## CERAMIC DEBURRING KNIVES

A totally safe and long-lasting blade that can deburr and deflash any hard plastics, as well as non-ferrous metals such as aluminium. The super ceramic material deburrs easily and allows operators true flexibility and complete safety.



### SMALL BLADE

6mm wide x 26mm long  
For intricate deburring

### STANDARD BLADE

15mm wide x 40mm long  
For easy to get into areas

CERAMIC KNIVES	
Large Blade	✓
Small Blade	✓
ORDER REF - DEBURRINGTOOL	

GRINDING

## CERAMIC MICRO FINISH KNIFE

Ideal for surface finishing on plastic moulding parts, excellent for small confined complex areas. The blade has two useable ends giving two unique shapes.

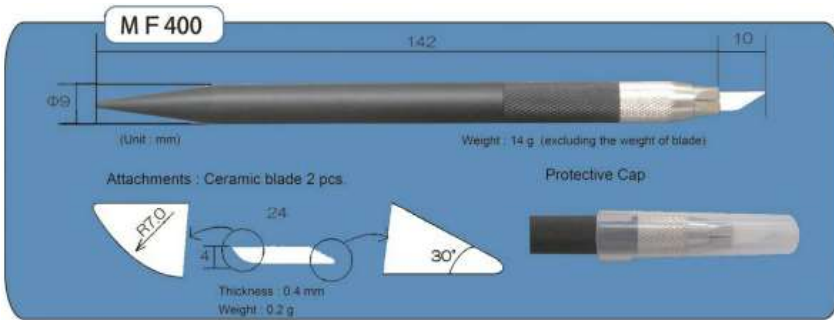

MICRO FINISH KNIFE	
	✓
ORDER REF - DEBURRINGCERAMIC	

## SHAVIV CURVED KNIFE

Shaviv Curve Ceramic deburring blade is used for deflashing and deburring soft metals and plastics. Specially designed for rounded edges, holes and curves.

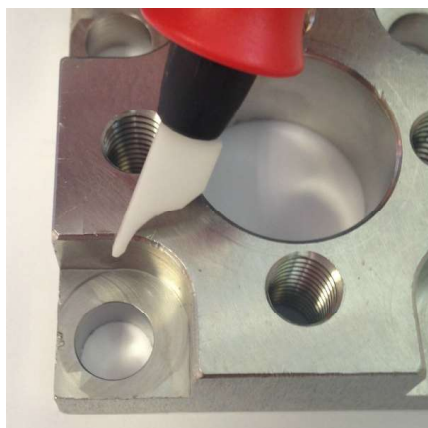

## SHAVIV ALUMINIUM WORKS KIT

The easiest and fastest way to hand deburr aluminium material. The kit contains 6 multi-purpose tools for deburring and chamfering a wide range of aluminium works.

SHAVIV KNIVES	
Type	
CURVED KNIFE	✓
ALUMINIUM WORKS KIT	✓
ORDER REF - DEBURRING(TYPE)	



**ALUMINIUM WORKS KIT**  
Your Profession Your Kit™ by SHAVIV  
Leading Deburring Solutions

**Handle A (Aluminum)**

**F Holder**

**F12 Inner Countersink**  
For chamfering hole edges up to 47° (12 mm) in diameter Hole Edge

**MB2000 Handle with E200 Replaceable Blade**  
For L + R hand deburring for powdery chips

**Replaceable Blade:**

**E300 Blade**  
For inner and outer deburring

Hole Edge Straight Edge

218-00418



**Micro-Mesh FLEXIFILES**

Double sided buffing sticks with Micro-Mesh laminated to both sides of 1/32" foam with a sturdy 0.060 styrene core. Ideal for hand finishing, particularly for removing parting lines and for small touch ups. See page 37 for grade chart.



<p><b>REGULAR FLEXI FILES</b></p> <p><b>DOUBLE SIDED 2 GRADE VARIATION</b> 1500/1800 2400/3200 4000/6000 8000/12000</p> <p><b>DOUBLE SIDED 1 VARIATION</b> ALL GRADES 1500 TO 12000</p>
---

<p><b>MX FLEXIFILES</b></p> <p><b>DOUBLE-SIDED 2 GRADE VARIATION</b> 60/80 MX 100/150 MX 180/240 MX 240/320 MX 400/600 MX 800/1200 MX</p> <p><b>DOUBLE SIDED 1 VARIATION</b> ALL GRADES 60 MX TO 1200 MX</p>
--

4-WAY FLEXIFILES	
Size	
3/8" (9.5mm) x 4	✓
1/2" (12mm) x 5 3/4"	✓
5/8" (15.9mm) x 5 3/4"	✓
<b>180 MX BLACK, 2400 R PINK, 4000 R WHITE, 12000g R GREY</b>	
<b>ORDER REF - MICFF-4WAY</b>	

3-WAY FLEXIFILES	
Size	
3/8" (9.5mm) x 4	✓
1/2" (12mm) x 5 3/4"	✓
5/8" (15.9mm) x 5 3/4"	✓
<b>2400 R BLACK, 4000 R WHITE, 12000g R GREY</b>	
<b>ORDER REF - MICFF-3WAY</b>	

2-WAY FLEXIFILES	
Size	
3/8" (9.5mm) x 4	✓
1/2" (12mm) x 5 3/4"	✓
5/8" (15.9mm) x 5 3/4"	✓
11/16" (17.5) X 7"	✓
<b>ORDER REF - MICFF-2WAY</b>	

**GRINDING**

**Micro-Mesh ANGLED FLEXI FILES**

Double sided files with Micro-Mesh abrasive laminated on either side of 1/32" foam with a sturdy 0.060 styrene core.

1/22" wide x 5 3/4" long, tapering to a 15 degree angle both ends.

Choose from:  
Set of 5 MX files - 800/1200, 400/600, 180/240, 100/150, 60/80

Set of 4 REGULAR - 8000/12000, 4000/6000, 2400/3600, 1500/1800 files.

Set of 5 DIAMOND files - 1200/1800, 400/800, 280/180, 120/100, 60/40



ANGLED FLEXIFILE VARIETY PACK		
TYPE	No of Files	
<b>MX</b>	<b>5</b>	✓
<b>REGULAR</b>	<b>4</b>	✓
<b>DIAMOND</b>	<b>5</b>	✓
<b>ORDER REF - MICFF-(TYPE)-VARIETY</b>		

## BRASS & GLASS FIBRE PENCILS

These pencils are perfect for fine work, used to clean after welding and in hard to reach areas.



BRASS & GLASS PENCILS & REFILLS		
TYPE	PENCIL	REFILL
Brass Pencil (1)	✓	✓
ORDER REF - BRASSWIRE		
Glass Pencil (1)	✓	✓
ORDER REF - GLASSFIBRE		

## COATED ABRASIVE HAND FILES

A handy way to use coated abrasives. Gives a comfy grip and produces flat finishing results.

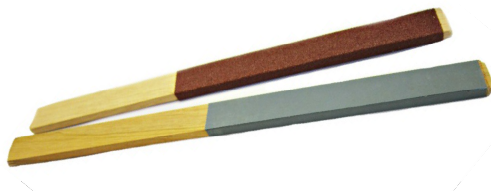

COATED ABRASIVE HAND FILES			
	Aluminium Oxide	Silicon Carbide	
4-Sided	60 80 120 180 240 320 400	ALL GRITS FROM 60G TO 2500G	✓
REPLACEMENT STRIPS			
Per Pack 20			
Replacement strips are self-adhesive backed, with release paper			
125 x 20mm	As Above	As Above	✓
ORDER REF - WHF			

GRINDING

## Micro-Mesh ABRASIVE BELT STICKS AND KITS

Sold per 10 in single grades or in a kit with 1 belt stick and one of each grade in either MX or Regular. 1/4" Only. Used wet or dry.

For Micro-Mesh Grades please see page 44



## ABRASIVE BELT STICKS AND KITS IN A/O

**Kits consists of:**  
2 Belt Sticks  
10 off each Belts in 80, 120, 240 & 320  
**Select Size**  
1/4", 1/2", 3/4"



BELT STICKS, BELTS & KITS				
MATERIAL	QTY		KIT QTY	KITS
1/4"X6 HOLDER	PER 1	✓	X	X
A/O BELTS	PER 10	✓	PER 40	✓
Micro-Mesh MX	PER 10	✓	PER 13	✓
Micro-Mesh REG	PER 10	✓	PER 9	✓
MATERIAL	QTY		KIT QTY	KITS
1/4"X6 HOLDER	1	✓	X	X
A/O BELTS	PER 10	✓	PER 40	✓
Micro-Mesh MX	PER 10	✓	X	X
Micro-Mesh REG	PER 10	✓	X	X
MATERIAL	QTY		KIT QTY	KITS
3/4" X 10" HOLDER	PER 1	✓	X	X
A/O BELTS	PER 10	✓	PER 10	✓
MATERIAL	QTY		KIT QTY	KITS
2" x 10" HOLDER	PER 1	✓	X	X
A/O BELTS	PER 10	✓	X	X
ORDER REF - ABBS / MIC-ABBS				

## VELCRO ABRASIVE HAND FILES

The benefit of a Velcro Hand File is that strips can be easily changed as they wear out with strips that fit straight on to the file without sticking or cutting.

Sold Individually or Refill Strips (30 x 195mm) Per 25



VELCRO HAND FILE	
EACH	✓
VELCRO STRIPS - PER 25	
30 x 195mm	✓
Velcro Strips Available in Aluminium Oxide 60 120 180 240 320 400 Foam Backed 60 120 220 400 600	
ORDER REF STRIP - SIAFAST-FILE-STRIP	
ORDER REF FILE - SIAFAST-FILE	

**DIAMOND HAND-E-FILES**

The tool interfacing consists of a flexible terylene resilient material, through which it is electroplated with nickel micro-pellets containing diamond abrasives. Diamond is the hardest abrasive available therefore it removes stock fast and retains its speed of cutting throughout its working life. The tool material is cool running. To obtain maximum lifespan, use with wet lubrication.

**Sold Per File or as Strip**

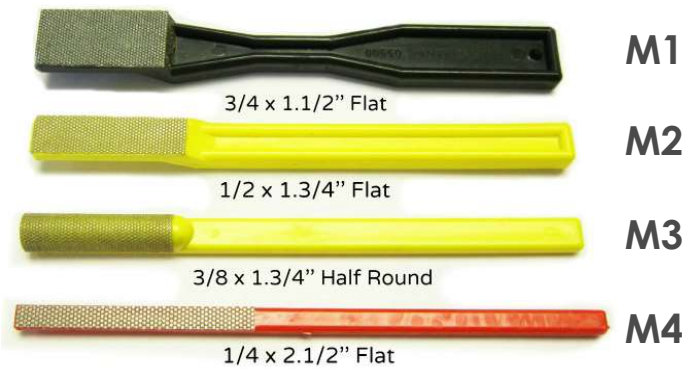

**Strips available to make your own tools**

This versatile self-adhesive diamond-coated cloth has many uses. It is easy to cut and shape to adapt to any tool. It can be fixed to wooden bobs, lapping sticks, files etc to suit many fine grinding operations.

HAND -E-FILES	ORDER REF - HEF
Single Files (each)	✓
Set of 4 Files	✓



DIAMOND STRIP			
Colour	Grit	Micron	
		Size	10x1/2" Strip
Green *	60/80	250	✓
Black	120	125	✓
Red	200	74	✓
Yellow	400	30~40	✓
White	800	15~30	✓
Blue *	1500	6~12	✓

ORDER REF - HEFST

**GRINDING**

**DIAMOND FOIL**

Diamond coated metal foil with galvanic bonding.

- Very high stock-removal, flexible and can be cut with scissors to your own tools.
- Excellent on Tungsten Carbide, Hardened Steels, Ceramics, Precious Metals etc
- Strip thickness 0.25-0.4mm, comes in two dimensions 10 x 100mm and 50 x 100mm

**See Joke Catalogue for More Details**

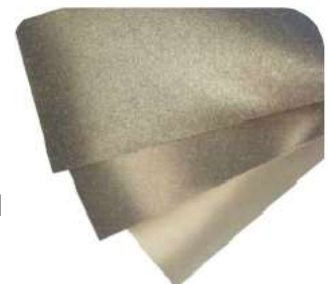

**SELF ADHESIVE STRIPS**

Flexible self adhesive strips with release paper backing. GRITS AVAILABLE - 60, 80, 100, 120, 150, 180, 240, 320, 400, 600, 800, 1000, 1200, 1500, 2000, 2500

\* only available as strip, not as files

SELF-ADHESIVE STRIPS	
Strip Size (mm)	20 Strips
25 x 280	✓
50 x 280	✓
75 x 280	✓
100 x 280	✓

ORDER REF - SAST

**QUICK ZIP STRIPS & FILES**

A low cost alternative to other methods for filing, deburring, or crevice and rib work for surface removal. Strips can be fixed both sides or one side only to the Quickzip Holder.

**Sold Per 50 Strips (50 x 7.5mm) or Per File**



QUICKZIP STRIPS	
All Grits Per 50	✓
Strip Grits: 100 150 240 320 400 500 600 800	

ORDER REF - QZ50(GRIT)

QUICKZIP FILES	
Flat, Flexy or Tapering	✓
File Types: Flat, Flexy and Tapering - Overall length 140mm	

ORDER REF - QZNF

# VALLORBE NEEDLE FILES



**GLARDON®**



by vallorbe swiss

## GROBET/VALLORBE NEEDLE FILES

Swiss made precision needle files - 16cm overall length  
Sold Per File (Boxed in 12's)

00 - V.COARSE 0- COARSE 2- MEDIUM (MOST POPULAR) 4- FINE

GRINDING



VALLORBE NEEDLE FILES					
Shape	Cuts	14cm	16cm	18cm	20cm
PILLAR	00/0/2	✓	✓	✓	✓
	4	✓	✓	✓	✓
HALF ROUND	00/0/2	✓	✓	✓	✓
	4	✓	✓	✓	✓
CROSSING	00/0/2	✓	✓	✓	✓
	4	✓	✓	✓	X
KNIFE	00/0/2	✓	✓	✓	✓
	4	✓	✓	✓	X
WARDING	00/0/2	✓	✓	✓	✓
	4	✓	✓	✓	X
3-SQUARE	00/0/2	✓	✓	✓	✓
	4	✓	✓	✓	✓

ORDER REF - E.g NF16HR

VALLORBE NEEDLE FILES					
Shape	Cuts	14cm	16cm	18cm	20cm
SQUARE	00/0/2	✓	✓	✓	✓
	4	✓	✓	✓	X
OVAL	0/2	✓	✓	✓	✓
	4	✓	✓	✓	X
ROUND	00/0/2	✓	✓	✓	✓
	4	✓	✓	✓	X
BARRETTE	00/0/2	✓	✓	✓	✓
	4	✓	✓	✓	X
PILLAR R.E	0	X	✓	X	X
	2	X	✓	X	X
CROCHET	00/0/2	X	✓	X	X
SLITTING	0/2	✓	✓	X	X

ORDER REF - E.g NF16HR



## FILE HANDLES

A variety of handles to suit a range of file sizes.

See description to select the correct handle.

FILE HANDLES	
Type	
VPL-B	✓
Crocodile (VAL410)	✓
FH-40 (VAL260)	✓
ORDER REF - NFH	

### FH-40 FILE HANDLE

For precision and needle files with a diameter of 3-4mm (Condor)



### CROCODILE FILE HANDLE

Blue plastic handle with hardened threaded insert - for precision files up to 350mm long.  
7 different sizes available, depending on the length of the file.  
6-8" Crocodile.



### VPL-B FILE HANDLE

Re-useable plastic handle  
Screw tightened



GRINDING

### SWISS VALLORBE 'BUDGET' FILE SETS

Swiss made needle files - 16cm overall length.

These lower cost files are made by Vallorbe in their Swiss factory renowned for its precision, guaranteeing better quality 'budget' files.



BUDGET FILES	
16cm Files	
Shape	
PILLAR	✓
WARDING	
3-SQUARE	
SQUARE	
ROUND	✓
BARRETTE	
HALF-ROUND	✓
CROSSING	✓
CROCHET	
PILLAR R.E.	
KNIFE	
SETS	
6-Piece Set	✓
ORDER REF - NFMIDGET	

### GROBET/VALLORBE NEEDLE FILE SETS

Swiss made precision needle files - 16cm overall length



VALLORBE NEEDLE FILE SETS	
16cm Cut 0 or Cut 2	
Set of 6	✓
Set of 12	✓
ORDER REF - NFS	



# DIAMOND MACHINE FILES



## DIAMOND MACHINE FILES

Diamond needle files on a 3mm shank. To fit all reciprocating machine tools.  
Available in 3 grades

**Coarse (D151) Medium (D126)  
Fine (D64)**



**SHORT FILE - TYPE DS**  
Overall length - 50mm  
Shank diameter - 3mm

SHORT FILE - TYPE DS	
Description	
FLAT	
2 x 1mm	✓
3 x 1 mm	✓
4 x 1 mm	✓
5 x 1 mm	✓
5 x 2 mm	✓
SQUARE	
2mm	✓
EDGE	
4 x 1mm	✓
TRIANGLE	
2mm	✓
4mm	✓
HALF-ROUND	
1.5mm rad.	✓
2mm rad.	✓
ROUND	
2mm	✓
4mm	✓
CROSSING	
5r x 2.5r	✓
ORDER REF - DFDS	

GRINDING



**LONG FILE - TYPE DL**  
Overall length - 85mm  
Shank diameter - 3mm

LONG FILE - TYPE DL	
Description	
FLAT	
5 x 1mm	✓
TRIANGLE	
3mm	✓
4mm	✓
SQUARE	
2.5mm	✓
HALF-ROUND	
2.5mm rad.	✓
ROUND	
3mm	✓
ORDER REF - DFDL	

**20 PIECE  
DIAMOND MACHINE FILE SET**  
Diamond needle files on a 3mm shank to suit reciprocating tools and supplied with a holder for hand use.



20 PIECE DIAMOND MACHINE FILE SET	
✓	
ORDER REF - DFSET-20P	

**DIAMOND RIFFLER FILE SET**  
Set of 6  
Medium Grade  
14cm overall length



DIAMOND RIFFLER FILE SET	
✓	
ORDER REF - DRF-SET	











**FOR INDIVIDUAL RIFFLER FILES  
SEE PAGE 38.**



## INDIVIDUAL DIAMOND NEEDLE FILES

16cm long diamond needle files.



<b>FLAT</b>		<b>ROUND</b>		<b>SLITTING</b>	
<b>TRIANGLE</b>		<b>H/ROUND</b>		<b>OVAL</b>	
<b>SQUARE</b>		<b>KNIFE</b>		<b>BARRETTE</b>	
<b>CROSSING</b>		<b>CROCHET/R.E. FLAT</b>			

16CM DIAMOND FILES	
GRADE	Each
D151 Coarse	✓
D126 Medium	✓
D64 Fine	✓
ORDER REF - DNF	

## DIAMOND TAPER HAND FILES

Medium Grade

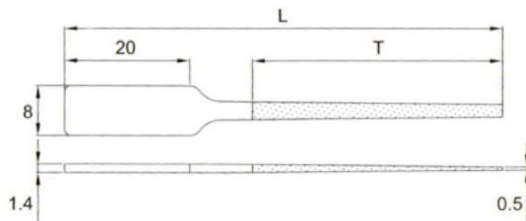

DIAMOND HAND FILE		
Size of file	Thickness of Taper	
180mm total length	2.5mm to 0.9mm	✓
70mm of diamond		
ORDER REF - DIAMONDHF		

GRINDING

## TAPERING NEEDLE FILES

Sets of 10 in one grade or a mixture. Colour coded handle for easy identification between grades.



TAPERING DIAMOND NEEDLE FILE SETS		
COLOUR	GRADE	SET OF 10
Black - Coarse	D100	✓
Red - Med/Coarse	D200	
Yellow - Med/Fine	D400	
Green Fine	D600	✓
Mixed Set	Mixed	
ORDER REF - DFSET-PTF		

## 6-PIECE DIAMOND NEEDLE FILE SET

16cm Medium Grade

- 2 off Flat
- 1 off Square
- 1 off Round
- 1 off Half Round
- 1 off Triangle



16CM SET OF 6
✓
ORDER REF - DNFSET

## FLEXIBLE DIAMOND FILES

14cm Flexible flat files.

0.8mm thick.

Available in Medium grade only.



Please Enquire for Price  
Order Ref - DNFMF

## SWISS RIFFLER FILES

Swiss made diesinkers riffler files. 15cm overall length.

Riffler files are used commonly in tool and die manufacturing but are also used in a range of industries. The various profiles and cross sectional shapes make them useful in tight, often unusual areas. Working much like a standard needle file, these files are double ended and suit being used by hand. Popular with mould tool manufacturers, engineers, jewellers etc

GRINDING

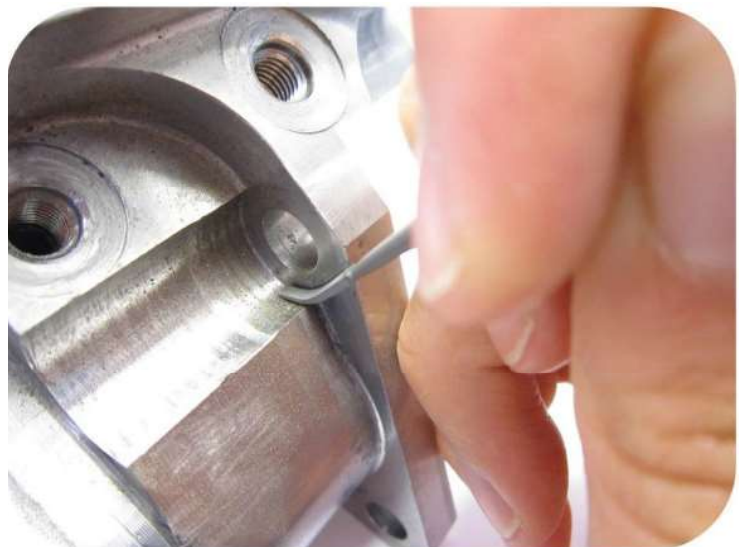
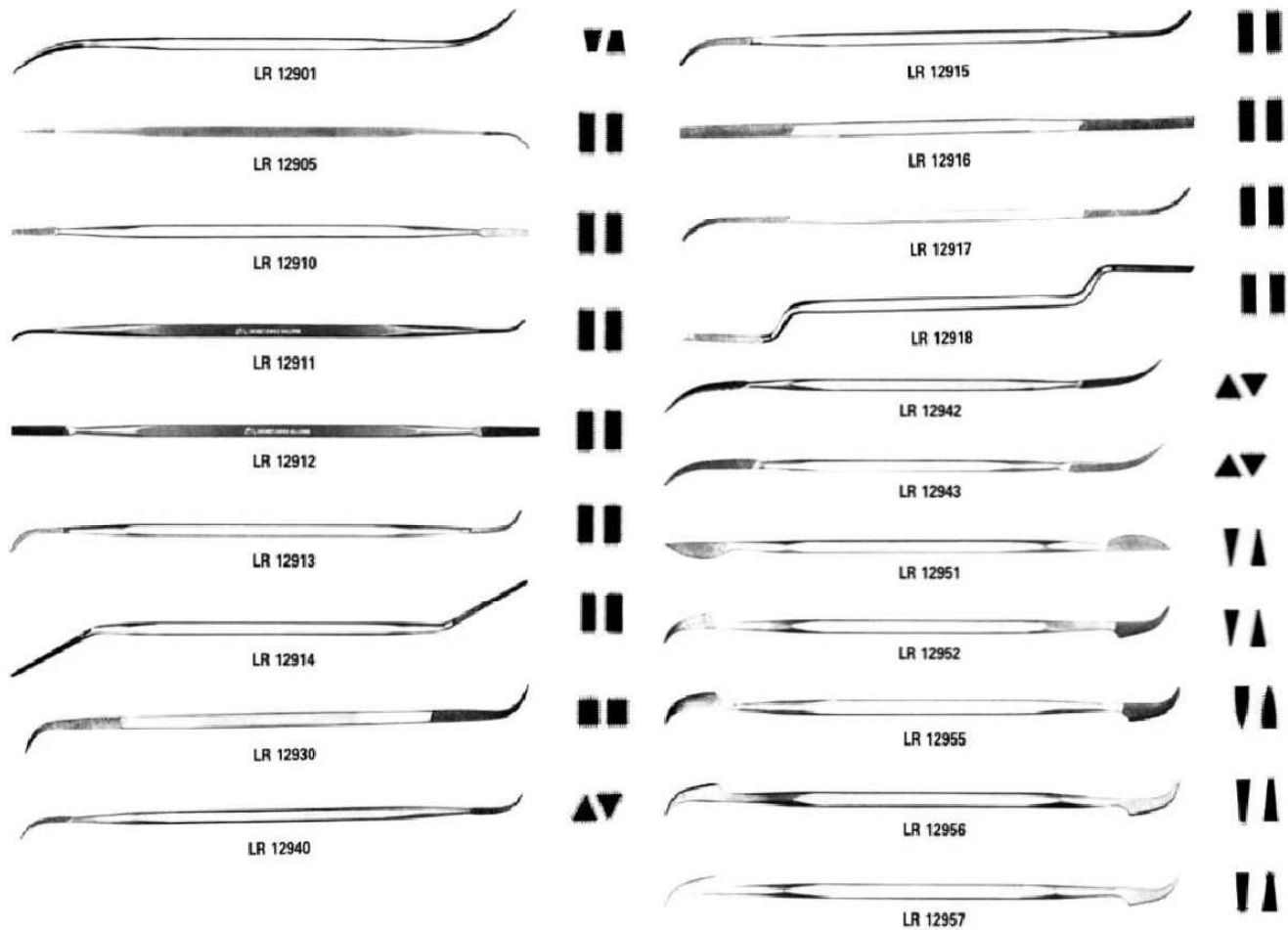

**SWISS RIFFLER FILES**

18cm also available

12700-12795

Please enquire for details

RIFFLER FILES		
Ref. No.	Cut 0	Cut 2
12916	X	✓
Rest of Files	✓	
12940	✓	X

ORDER REF - R(REF NO.)

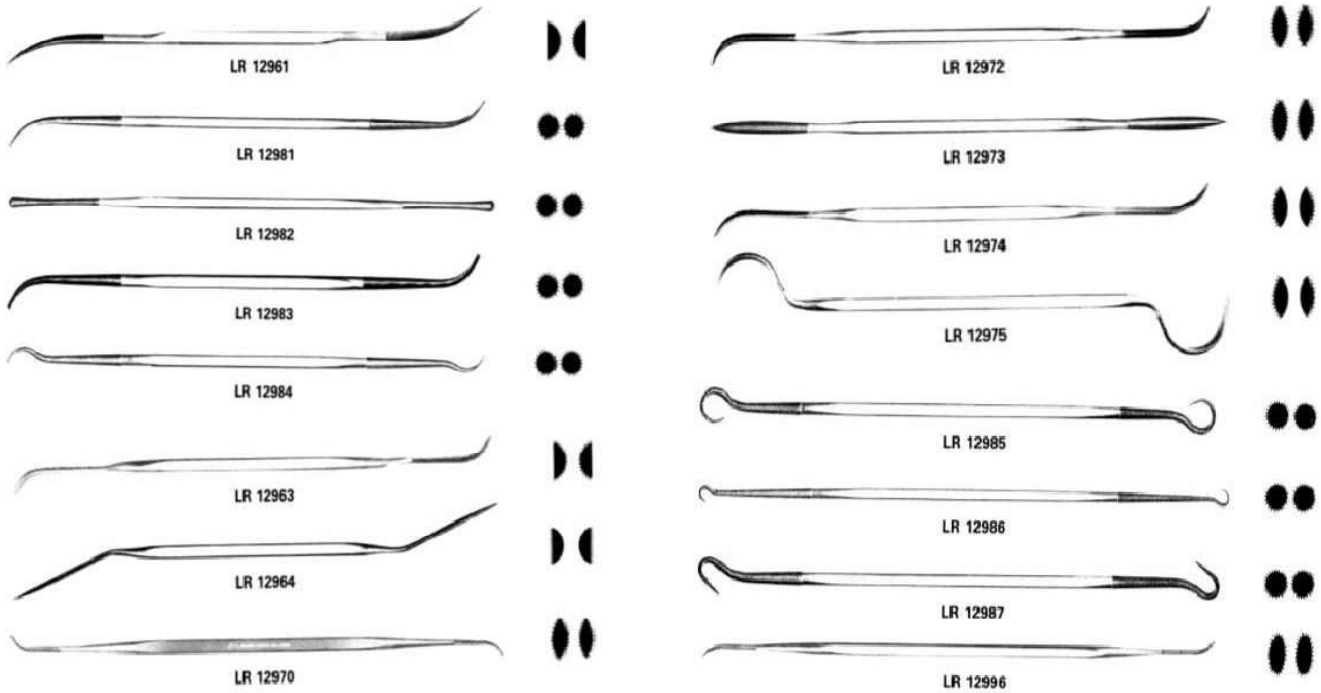

GRINDING







## FLEX-HONES

Cross hole deburring and internal bore surface finishing. With heavy duty flexible shaft 3/8" chuck, you can use up to 1.1/2" diameter brush. You can use a 10mm diameter brush with our LY128 pendant motor, but no larger.

### Sold Individually

FLEX-HONES					
BC 4mm	(0.157")	BC 11mm	(0.433")	BC 1.1/4"	(31.8mm)
BC 4.5mm	(0.177")	BC 12mm	(0.472")	BC 1.3/8"	(35mm)
BC 3/16"	(4.75mm)	BC 1/2"	(12.7mm)	BC 1.1/2"	(38mm)
BC 5mm	(0.197")	BC 14mm	(0.552")	BC 1.5/8"	(41mm)
BC 5.5mm	(0.217")	BC 5/8"	(16mm)	BC 1.3/4"	(45mm)
BC 6.4mm	(0.250")	BC 18mm	(0.709")	BC 2"	(51mm)
BC 7mm	(0.276")	BC 3/4"	(19mm)	BC 2.1/4"	(57mm)
BC 8mm	(0.315")	BC 20mm	(0.787")	BC 2.1/2"	(64mm)
BC 9mm	(0.354")	BC 7/8"	(22mm)	BC 2.3/4"	(70mm)
BC 9.5mm	(0.375")	BC 1"	(25.4mm)	BC 3"	(76mm)
BC 10mm	(0.394")	BC 1.1/8"	(29mm)		

ORDER REF - FLEXH

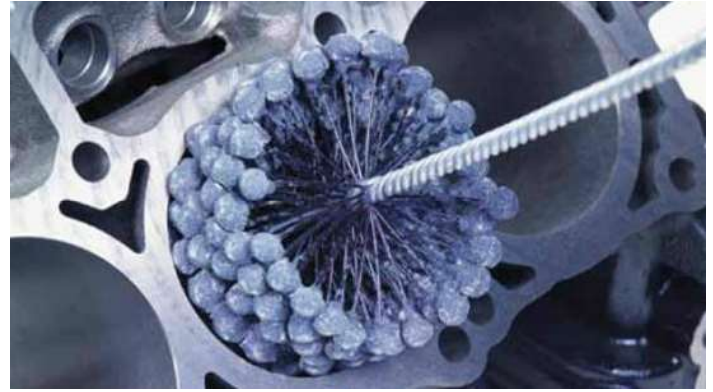

For heavy applications, where a very even finish is required, Flex-Hones are the best tool for the job. The usual grade would be 180g S/C. This will remove material, as opposed to abrasive nylon and stainless steel which will only remove the burs.

Available in **Silicon Carbide, Aluminium Oxide, Boron Carbide, Tungsten Carbide & Aluminium Zirconia**, with grits ranging from 40 to 320.

GRINDING

## MOUNTED ABRASIVE NYLON TUBE BRUSHES

On a 6mm shank so can be used in a slow speed, high torque machine. Well suited to a collet system.

### Sold Individually 6mm Shank



MOUNTED ABRASIVE NYLON TUBE BRUSHES								
Part No.	Hole	Brush	Overall	Shank	Grits			Max.RPM
	Dia.	Length	Length	Dia.	120 Med	240 Fine	320 X-Fine	
GTS-05	5mm	50mm	100mm	6mm	✓	X	✓	10000
GTS-06	6mm				✓	X	✓	7000
GTS-08	8mm				✓	X	✓	7000
GTS-10	10mm				✓	✓	X	5000
GTS-13	13mm				✓	✓	X	5000
GTS-16	16mm				✓	✓	X	5000

ORDER REF - GTS-(No)

## SERIES 81-A CROSS HOLE DEBURRING MINI BRUSH KIT

Ideal for micro burr removal, internal cleaning, rust removal and surface preparation. Kits contains 12 brushes. The metric kit includes 1mm, 1.5mm, 2mm, 2.5mm, 3mm, 3.5mm, 4mm, 4.5mm, 5mm, 5.5mm, 6mm and 6.5mm sizes. Also included with this selection is a premium double end pin vise which provides a safe and secure means of using the brush.



**SERIES 81-A MINI KIT**  
**STAINLESS STEEL** ✓  
ORDER REF - TIW81AMMKIT

## ORBITOOL

This tool is specially designed for removing the burrs created during cross drilling. The tool consists of a specially designed and shaped cutter and a flexible holder. The cutters can be used on their own due to the flexible shank. They are available in various sizes and shank diameters.

### Please Enquire For More Information



## MITCHELLS ABRASIVE STRING

Abrasive string can be used in any number of ways to aid deburring and polishing in difficult to reach areas such as small holes, slots and grooves. The string is rip resistant & does not fray. It's very easy to use.

Sold Per 15M Spool



MITCHELLS STRING			
Order Ref	DIA	GRIT/TYPE	
<b>ALUMINIUM OXIDE</b>			
MIT-48-AO	.093" or 2.36mm	150 grit AO	✓
MIT-49-AO	.082" or 2.08mm	120 grit AO	✓
MIT-51-AO	.055" or 1.4mm	120 grit AO	✓
MIT-52-AO	.055" or 1.4mm	150 grit AO	✓
MIT-53-AO	.040" or 1.02mm	180 grit AO	✓
MIT-54-AO	.030" or 0.76mm	200 grit AO	✓
<b>SILICON CARBIDE</b>			
MIT-50-SC	.070" or 1.78mm	180 grit SC	✓
MIT-51-SC	.055" or 1.4mm	120 grit SC	✓
MIT-52-SC	.055" or 1.4mm	150 grit SC	✓
MIT-54-SC	.030" or 0.76mm	200 grit SC	✓
MIT-60-SC	.015" or 0.38mm	200 grit SC	✓
MIT-66-SC	.012" or 0.31mm	280 grit SC	✓
ORDER REF - MIT-			

GRINDING

## MITCHELLS ABRASIVE TAPE

Abrasive tape much like the string is excellent for detailed finishing in even tighter areas.

Sold Per 15M Spool

MITCHELLS TAPE			
REF	WIDTH (INCHES)	GRIT/TYPE	
AB59	0.25"/6.35mm	150-GRIT	✓
AB59C	0.25"/6.35mm	CROCUS( ULTRA FINE )	✓
AB56C	0.093"/2.36mm	CROCUS (ULTRA FINE)	✓
ORDER REF - MIT-AB			



PLASTIC BACKED MICRO GRINDING TAPE (22.5m Long Roll)				
Dimensions mm	Thickness mm	GRIT/ABRASIVE		ORDER REF
22.5m x 6mm	0.4	360grit/40 micron	✓	JOKE-0401474
		1000grit /15micron	✓	JOKE-0401476
22.5m x 10mm	0.4	240 grit /60 micron	✓	JOKE-0401483
		560 grit/30 micron	✓	JOKE-0401485

## FLEXIBLE BORE CLEANERS

Flexible but firm, these bore cleaners are particularly useful for reaching into bores. They can be used on their own dry or with compound. Diamond compound or Ultralap would be particularly useful. Use by hand or in the chuck of a rotary tool.

Sold Per 50

FLEXIBLE BORE CLEANERS	
SIZE	
3mm ø x 30cm long	✓
9mm ø x 30cm long	✓
ORDER REF - PIPE	



## WET & DRY PAPER

### Flexible Waterproof Silicon Carbide Latex Backed Sheets

Excellent quality matador wet and dry paper. The latex backing adds strength and durability.



**Sold Per 50 Sheet Pack**

WET & DRY ASSORTMENTS		
Set No	5 Sheets of Each Grit	
SET NO.1	80-120-180-240-320-600-1000-1500 grit	✓
SET NO.2	60-100-150-240-320-400-800-1200 grit	✓
ORDER REF - WADSETNO(1 OR 2)		

## ALUMINIUM OXIDE SHEETS

Excellent quality aluminium oxide cloth sheets for all types of metal work.

Thicker, longer lasting, very heavy wearing compared to regular wet and dry.

**Sold Per 50 Sheet Pack**



## ALUMINIUM OXIDE ECONOMY ROLL

Non shredding and very flexible, with even and long-lasting cut.

- Aluminium Oxide
- Flexible 'F' weight Cloth - Grade RB346JF

**Sold Per Roll (50m)**



## BEST QUALITY ECONOMY ROLL

Especially selected for Tool Steels. Grade RB346MJ - 25mm x 50m Rolls (Aluminium Oxide)

**Sold Per Roll (50m)**



**WET & DRY ECONOMY ROLL**  
Silicon Carbide abrasive roll.  
**Sold Per Roll (25mm x 50m)**

BEST QUALITY ECONOMY ROLL (RB346MJ)									
GRITS									
40	60	80	120	180	240	320	400	600	800
✓	✓	✓	✓	✓	✓	✓	✓	✓	✓
ORDER REF - ER25-(GRIT)									

WET & DRY ECONOMY ROLL		
Size	GRIT	
25mm X 50m	600, 800, 1000, 1200	✓
ORDER REF - ERWAD		

WET & DRY SHEETS	
GRIT	
60	✓
80	✓
100	✓
120	✓
150	✓
180-1200	✓
1500-2500	✓
3000	✓
5000	✓
7000	✓
ORDER REF - WAD(GRIT)	

CLOTH SHEETS	
GRIT	
60	✓
80	✓
120	✓
180	✓
240	✓
320	✓
400	✓
500	✓
600	✓
ORDER REF - CLOTHSH(GRIT)	

ECONOMY ROLL (RB346JF)			
	GRITS		
Width	60	80	100-400
25mm	✓	✓	✓
50mm	✓	✓	✓
ORDER REF - ER(WIDTH)			

GRINDING



## RODA ABRASIVE HANDPADS



RODA Abrasive nylon scotch hand pads are used to give a satin/sateen finish most commonly on metal. Depending on the grade selected, different finishes can be achieved.

The pads are simple to use on their own and can be cut to size with scissors. The hand pads are impregnated throughout with grit, therefore they work on their own without the need for compound.

Sold in packs of 10 (229 x 152mm)



**MOLERODA RECOMMENDS**

## ABRASIVE SANDING BLOCKS

Made of special resilient rubber, filled with hard abrasive grit, which is evenly distributed through the block. The blocks provide a constant finish, unlike abrasive cloths and papers which become finer in use.



## WOODEN HANDLED BRUSHES

Hand brushes in various materials.  
Sold Per Brush



## ABRASIVE NYLON CLEANING & FINISHING ROLLS

For an extremely economical option simply tear off sections as needed.

**Sold Per 150mm x 10m Roll Note-**

Other roll sizes available from 25mm (1") to 17000mm (66") wide x 10m long.



### ABRASIVE NYLON ROLL & HAND PADS

Colour	Grade	10 Mtr Roll	229 X 152mm x 10
Green	<b>G/P Green</b>	✓	✓
Grey	<b>Ultra Fine S</b>	✓	✓
Maroon	<b>Very Fine A</b>	✓	✓
	<b>Medium A</b>	✓	✓
	<b>Coarse A</b>	✓	✓
	<b>Heavy Duty MA</b>	✓	✓
	<b>Heavy Duty Very CA</b>	✓	✓
Black	<b>Black Super Cut</b>	✓	✓
Brown	<b>Superior Brown</b>	✓	✓

ORDER REF - SCOTROLL150X10(GRADE)

ORDER REF - SCOTHP(GRADE)

**FOR MORE INFORMATION ON ABRASIVE NYLON GRADES PLEASE GO TO PAGE 70**

### ABRASIVE SANDING BLOCKS

Grade	Grit	Size	
<b>Extra Coarse - WINE</b>	36	80 x 50 x 20mm	✓
<b>Coarse - BLUE</b>	60		
<b>Medium - GREY</b>	120		
<b>Fine - BROWN</b>	240		

ORDER REF - ABRABLOCK(GRADE)

### HAND BRUSHES

Specification	Overall Length	Rows	
<b>Stiff Black Bristle</b>	280mm	6	✓
<b>Med/Soft White Bristle</b>	230mm	4	✓
<b>Stiff White Nylon</b>	280mm	6	✓
<b>Steel</b>	280mm	4	✓
<b>Brass</b>	280mm	4	✓

ORDER REF - WOODH-(ROWS & MATERIAL)



**Micro-Mesh is made with a cloth backing, followed by a layer of specially formulated latex. Silicone carbide or aluminium oxide grit is bonded on the ultra fine cloth with flexible glue and is perfect for polishing, cleaning and finishing.**

Can be used with water or used dry, it can even be rinsed and reused making Micro-Mesh the economical choice for professionals in a wide range of industries.

**Regular:** Used for plastics, woods and painted surfaces.

**MX:** Used for finishing metals, and other hard surfaces.

**AO:** for polishing Corian work tops

Micro-Mesh REGULAR	Micro-Mesh MX	Micro-Mesh ALUMINUM OXIDE	FEPA OR EURO	MICRON
			P120	125
			P150	100
		<b>300 AO</b>	P180	80
			P220	65
	<b>60 MX</b>		P240	60
			P280	
			P320	52
				50
	<b>80 MX</b>		P360	45
	<b>100 MX</b>	<b>600 AO</b>		
	<b>120 MX</b>		P400	42
			P500	
	<b>150 MX</b>	<b>800 AO</b>		
			P600	40
<b>1500 R</b>	<b>180 MX</b>	<b>1500 AO</b>		30
			P800	
			P1000	20
			P1200	
<b>1800 R</b>	<b>240 MX</b>	<b>1800 AO</b>		15
			P1500	13
<b>2400 R</b>	<b>320 MX</b>	<b>2400 AO</b>		
			P2000	
				10
			P2500	9
<b>3200 R</b>	<b>360 MX</b>	<b>3200 AO</b>		
<b>3600 R</b>	<b>400 MX</b>	<b>3600 AO</b>		8
<b>4000 R</b>	<b>600 MX</b>	<b>4000 AO</b>		5
<b>6000 R</b>	<b>800 MX</b>	<b>6000 AO</b>		4
<b>8000 R</b>	<b>1200 MX</b>	<b>8000 AO</b>		3
<b>12000 R</b>		<b>12000 AO</b>		1

Micro-Mesh Rolls are a very economical way to buy, choose from two different lengths.



### Micro-Mesh ROLLS ALL GRADES - MX, REGULAR AND AO

SIZE	
<b>6" X 25 FT (150MM X 7.62M)</b>	✓
<b>6" X 50 FT (150MM X 15.24M)</b>	✓

ORDER REF - MIC-150X

GRINDING

Micro-Mesh Sheets are a great way to sample the material or if only a small amount is required.

**AO - MX- REGULAR**



### MICROMESH SHEETS

SIZE	
<b>12" x 6"</b>	✓
<b>6" x 6"</b>	✓
<b>3" x 6"</b>	✓

ORDER REF - MIC(GRIT)



### FOAM BLOCK

SIZE	
<b>2"X3"</b>	✓
<b>3"X4"</b>	✓

ORDER REF - MIC-FOAMBLOCK

# MICRO-MESH HAND FINISHING KITS



## SOLID SURFACE CORIAN KIT

This repair kit is perfect for touching up and polishing out burns, stains and scratches in solid surfaces like Corian. Restore your kitchen and bathroom countertops back to a smooth shiny finish with these 4 re-useable pads.



SOLID SURFACE CORIAN KIT	
CODE	
3KCOUNTER	✓
MIC-KIT-CORIAN	✓
ORDER REF - MIC-KIT-3KCOUNTER	

## SOLID SURFACE CORIAN REPAIR AND POLISHING KIT

Kit as above but with the addition of a Micro-Mesh 12" square polishing cloth and micro gloss. Water based polish and cleaner formulation that contains abrasive crystals in micron gradings. Use after the pads as a final step to add lustre.

## SOLID SURFACE CORIAN DISC KIT

This kit is designed for more heavy duty repairs and scratch removal on Corian and other similar surfaces. Use with an orbital sander.



SOLID SURFACE CORIAN DISC KIT	
CODE	
3KCOUNTER	✓
ORDER REF - MIC-KIT-3KCOUNTER	

The discs can be used wet or dry and finished with micro gloss. Kit comes with 7 6" AO with Velcro backing. Discs range from grades 300-12000.

## METAL POLISHING KIT MX-90

For touching up and polishing small areas by hand. Sheet and flexifiles. Kit comes with 11 sheets of MX Micro Mesh sheets which range from 100 MX (320 Grit FEPA) to 1200MX (3 Micron RA – ultra fine)



METAL POLISHING KIT MX-90	
CODE	
3KMX90	✓
ORDER REF - MIC-KIT-MX90	

## CRAFT KIT

Polishing plastic kit contains a set of 2" soft touch pads with grades from 1500 (800g) to 12000 (1 Micron ultra fine). Polishing flexi files and liquid polishing abrasive.



CRAFT KIT	
CODE	
3KCRAFT	✓
ORDER REF - MIC-KIT-CRAFT	

## HOBBY KIT

Restoring transparency to clear and coloured acrylics – plexiglas, acrylite, Lucite and Polycast. Restoring surface finish and remove minor damage on fibreglass, gel-coat, polyester, acrylic and other plastic surfaces also cultured marble. Polishing hard wood such as Mahogany, Teak, Oak and Ebony.



HOBBY KIT	
CODE	
HOBBY	✓
ORDER REF - MIC-KIT-HOBBY	

GRINDING

## ACRYLIC & POLYCARBONATE KIT

Micro Mesh kit for Acrylic and Polycarbonate restoration. Very popular for work on aerospace parts- Micro-Mesh has been approved by Boeing / McDonnell Douglas, the Military and FAA. Will restore up to 30 square feet of material.



### ACRYLIC & POLYCARBONATE KIT

CODE	
KR70	✓
ORDER REF - MIC-KIT-KR70	

## ACRYLIC HAND POLISHING KIT

This kit is used by hand to restore up to 60 square feet of aircraft transparencies or other acrylic surfaces. 16 off 3 X 6" sheets, foam block, micro-gloss and polishing cloth.



### ACRYLIC HAND POLISHING KIT

CODE	
HP100	✓
ORDER REF - MIC-KIT-HP100	

## STAINLESS STEEL KIT

This easy to use kit will remove surface scratches and damage caused by utensils, pots and pans, non-woven cleaners and steel wool. Colour-coded Micro-Mesh pads and micro-gloss.



### STAINLESS STEEL RESTORAL KIT

CODE	
3DLSIRK01	✓
ORDER REF - MIC-KIT-STAINLESSKIT	

## RESTORAL AND FINISHING KIT

For restoral on plastic, wood and paint. This kit will restore up to 30 square feet of plastic surface. It is one of the most complete kits for use by hand.



### RESTORAL AND FINISHING KIT

CODE	
NC-78-1	✓
ORDER REF - MIC-KIT-NC-78-1	

## FISH TANK MAINTENANCE KIT

For use on acrylic tanks to remove scuffs and scratches. Abrasives may be used on the inside of the tank with fish and water in place, however we suggest removing to avoid any contamination.



### AQUARIUM KIT

CODE	
3KAQK	✓
ORDER REF - MIC-KIT-AQUARIUM	

## TUB & SPA KIT

5 off 2 X 2" Soft touch pads, Micro-gloss liquid and a polishing cloth. Removes scratches and burn marks.



### TUB & SPA KIT

CODE	
3KTSK	✓
ORDER REF - MIC-KIT-3KTSK	

# MICRO-MESH POWER TOOL KITS



## POLYCARBONATE RECTIFICATION KIT

- 1 - 5" No Hole Loop Back Disc, 2400 Micro-Mesh
- 1 - 5" No Hole Loop Back Disc, 3600 Micro-Mesh
- 1 - 5" Black Lambswool TufBuf Polishing Pad
- 1 - 5" White Sponge Polishing Pad
- 1 - 5" Hook face extra soft back-up pad with cordless drill shank
- 1 - 8 ounce Bottle Micro-Gloss #5 Liquid Abrasive
- 1 - 8 ounce Bottle Micro-Gloss Liquid Abrasive
- 1 - 8 ounce Bottle Final Finish
- 2 - Polishing Cloth



POLYCARBONATE RECTIFICATION KIT	
CODE	
<b>3KPOLY</b>	✓
ORDER REF - MIC-KIT-POLYCARBONATE	

GRINDING

## CLEARSEAS KIT

Remove scratches, scuffs and haze for up to 100 square feet of acrylic. Use on acrylic hatches, portholes, windshields and doors. This kit is designed to be used with a cordless drill.

Kit contents include:

- 2 - 5" Loop Discs, Micro-Mesh 1500
- 2 - 5" Loop Discs, Micro-Mesh 2400
- 2 - 5" Loop Discs, Micro-Mesh 3600
- 1 - 8 oz. Micro-Gloss liquid abrasive
- 1 - 8 oz. Anti - Static Creme
- 1 - 5" Hook face, soft backup pad w/drill mandrel
- 1 - 5" Black natural lambswool pad
- 1 - 5" Micro-Surface soft foam polishing pad
- 2 - Micro-Surface cotton flannel cloths
- 1 - Instructions



CLEARSEAS ACRYLIC RESTORAL KIT	
CODE	
<b>3KCLRA</b>	✓
ORDER REF - MIC-KIT-3KCLRA	

## LEADING EDGE KITS

For unpainted, aluminium surface. Perfect for leading edges, vertical and horizontal stabilizers, engine nose cowls and thrust reversers. Removes oxidation, corrosion, orange peel, and surface scratches. Provides a uniform high lustre gloss.



3" LEADING EDGE KIT	
CODE	
<b>3KAOLE3</b>	✓
ORDER REF - MIC-KIT-3KAOLE3	

5" LEADING EDGE KIT	
CODE	
<b>3KAOLE</b>	✓
ORDER REF - MIC-KIT-3KAOLE	

## DRILL HEADLIGHT RESTORAL KIT

- 6 wet/dry sandpaper 3" loop discs
- 2 - 1500 Micro-Mesh 3" loop discs
- 2 - 2400 Micro-Mesh 3" loop discs
- 2 - 3600 Micro-Mesh 3" loop discs
- 1 - 3" TufBuf lambswool buffing pad
- 1 - 4 oz. bottle Micro-Gloss liquid abrasive
- 1 - Instructions



DRILL HEADLIGHT RESTORAL KIT	
CODE	
<b>3KHDGTM</b>	✓
ORDER REF - MIC-KIT-HEADLIGHT-3KHDGTM	



**LIGHT DAMAGE REMOVAL KIT**

This kit removes minor scratches and scuffs. Restores up to 100 square feet of acrylic to optical clarity. Use with a 5" random orbital sander. Also very good for plexiglass which can be tricky to polish.

Kit contents include:

- 2 - 5" Loop Discs, Micro-Mesh 1500
- 2 - 5" Loop Discs, Micro-Mesh 2400
- 2 - 5" Loop Discs, Micro-Mesh 3600
- 1 - 8 oz. Micro-Gloss liquid abrasive
- 1 - 8 oz. Anti - Static Creme
- 1 - 5" Hook face, soft backup pad
- 1 - 5" Natural lambswool pad
- 1 - 5" Micro-Surface soft foam polishing pad
- 2 - Micro-Surface cotton flannel cloths
- 1 - Instructions

**Tools Required**

- Random orbital sander.
- Angle Polisher, (Rated at approx. 2500 RPM), with 4.75-inch diameter.
- Hook Back-Up pad.
- Compressed Air - 120 pounds per square inch.
- Spray bottle - approximately 10-ounce capacity.

**MAINTENANCE KITS**

These kits remove very minor surface scratches and haze in acrylics and plastics. Restores up to 100 square feet of acrylic to optical clarity.



**TUF-BUF LAMBSWOOL PADS**

Use in conjunction with liquid abrasive compounds. Premium shearing lambswool pads are durable and soft enough to leave less haze and swirl than felt or mops. For an even and consistent finish on plastics, clearcoat and metals.

**BACKING PADS**

M14 Backing pads to suit the lambswool pads. Ideal for angle grinders.



ORBITAL SANDER DAMAGE REMOVAL KIT	
CODE	
3KHDK	✓
ORDER REF - MIC-KIT-3KHDK	

CORDLESS DRILL DAMAGE REMOVAL KIT	
CODE	
3KLDK	✓
ORDER REF - MIC-KIT-3KLDK	



**GRINDING**

MAINTENANCE KIT - CORDLESS DRILL	
CODE	
3KMRKD	✓
ORDER REF - MIC-KIT-3KMRKD	

MAINTENANCE KIT - ROTARY BUFFER	
CODE	
3KMRK	✓
ORDER REF - MIC-KIT-3KMRK	

TUF-BUF LAMBSWOOL PADS	
Size	
3" Dia. X 1" Nap	✓
5" Dia. X 3/4" Nap	✓
6" Dia. X 1" Nap	✓
6" Dia. X 3/4" Nap	✓
ORDER REF - MIC-TUF-BUF	

## KITCHEN & BATH MAINTENANCE KIT

Scratch Away Sink Restore Kit - Removes surface scratches and damage caused by utensils, pots and pans etc. Scratch Away Countertop Restore Kit removes stains, burn marks and scratches from solid surface countertops such as Corian. Scratch Away Tub and Spa Restore Kit - removes discolouration, scratches, scuffs and even burn marks from tubs, spas and tub surrounds.



KITCHEN & BATH MAINTENANCE	
CODE	
<b>3KBS3</b>	✓
<b>ORDER REF - MIC-KIT-3KBS3</b>	

GRINDING

## CLEARCOAT REPAIR KIT

1 – 2" x 3" Soft Touch Pad, 2400/3600 Micro-Mesh

1 – 2" x 3" Soft Touch Pad, 4000/6000 Micro-Mesh

1 – 2" x 3" Soft Touch Pad, 8000/12000 Micro-Mesh

1 – 1 oz. Bottle, Micro-Gloss

1 – Polishing Cloth

1 – Set of Instructions



CLEARCOAT REPAIR KIT	
CODE	
<b>3KPAINT</b>	✓
<b>ORDER REF - MIC-KIT-3KPAINT</b>	

## HEADLIGHT / LANDING LIGHT REPAIR KIT

Micro-Mesh Landing Light (Plexiglass) Repair Kit for landing lights on aeroplanes as well as other similar plastic items.

4 double sided soft touch pads 3 x 4", soft cloth and compound.



LANDING LIGHT REPAIR KIT	
CODE	
<b>3KLENS</b>	✓
<b>ORDER REF - MIC-KIT-3KLENS</b>	

## BURN KIT

Micro-Mesh 3" x 6" sheets: 1500, 1800, 2400, 3600, 4000, 6000, foam block, Micro-Gloss and 1 polishing cloth.

Restore marble, solid surface, fibreglass and acrylic with this kit. Removes burn marks, stains, discolourations, scratches and surface defects. Great for restoring vanities, sinks, tubs and tub surrounds.



BURN KIT	
CODE	
<b>3KBURN</b>	✓
<b>ORDER REF - MIC-KIT-BURN-3KBURN</b>	

## PROFESSIONAL WOOD WORKERS KIT

This kit is designed for craftsmen to replace the use of steel wool, rottenstone or pumice. May be used on bare or finished wood, an excellent way to spot match finishes. Can be used wet or dry to achieve matte, satin or high gloss finishes.

Kit contents:

- 2 - 3" x 6" sheets Micro-Mesh 1500
- 2 - 3" x 6" sheets Micro-Mesh 1800
- 2 - 3" x 6" sheets Micro-Mesh 2400
- 2 - 3" x 6" sheets Micro-Mesh 3200
- 2 - 3" x 6" sheets Micro-Mesh 3600
- 2 - 3" x 6" sheets Micro-Mesh 4000
- 2 - 3" x 6" sheets Micro-Mesh 6000
- 2 - 3" x 6" sheets Micro-Mesh 8000
- 2 - 3" x 6" sheets Micro-Mesh 12000
- 1 - 3" x 3" micro-surface foam block



### PROFESSIONAL WOOD WORKERS KIT

CODE	
<b>3KWOOD</b>	✓
<b>ORDER REF - MIC-KIT-PROFESS</b>	

GRINDING

Micro-Mesh Sheet laminated on a foam core that provides added flexibility and conformity. Particularly good for curved surfaces. Packed into sets.

**AO - 7 pads, one of each grit - Yellow**

**MX - 13 pads, 1 of each grit - Grey**

**REGULAR - 9 pads, 1 of each grit - Colour Coded**



### 2" X 2" SOFT PADS VARIETY PACKS

<b>MX VARIETY</b>	✓
<b>AO VARIETY</b>	✓
<b>REGULAR VARIETY</b>	✓
<b>SINGLE PAD - ANY GRADE</b>	✓
<b>ORDER REF - MIC-2X2SOFTPAD-(TYPE)</b>	

### 3" X 4" SOFT PADS VARIETY PACKS

<b>MX VARIETY</b>	✓
<b>AO VARIETY</b>	✓
<b>REGULAR VARIETY</b>	✓
<b>SINGLE PAD - ANY GRADE</b>	✓
<b>ORDER REF - MIC-3"X4"SOFTPAD-(TYPE)</b>	

Micro-Mesh Swabs comprise of rounded foam tips coated with Micro-Mesh. Grits are colour coded for easy identification. These swabs are handy when you can't get your tool to fit.

**Sets include 12 swabs,  
1 of each grade from 100 MX  
to 12000.**



### Micro-Mesh SWABS

Size	
<b>2" VARIETY</b>	✓
<b>3" VARIETY</b>	✓
<b>5" VARIETY</b>	✓
<b>ORDER REF - MIC-SWABS</b>	

# CARBIDE BURR BASIC FLUTING STYLES

Plain cut and double cut can be ordered with a 'fine cut' - twice the number of cuts giving more control and better finish.

**PLAIN CUT**



**DOUBLE CUT**



**DIAMOND CUT**



GRINDING

General purpose fluting. The second most popular fluting style.

The most popular of all fluting styles. Very efficient stock removal. Creates a small chip.

For use on heat treated and tough alloy steels, where control is important. Creates a powder-like chip.

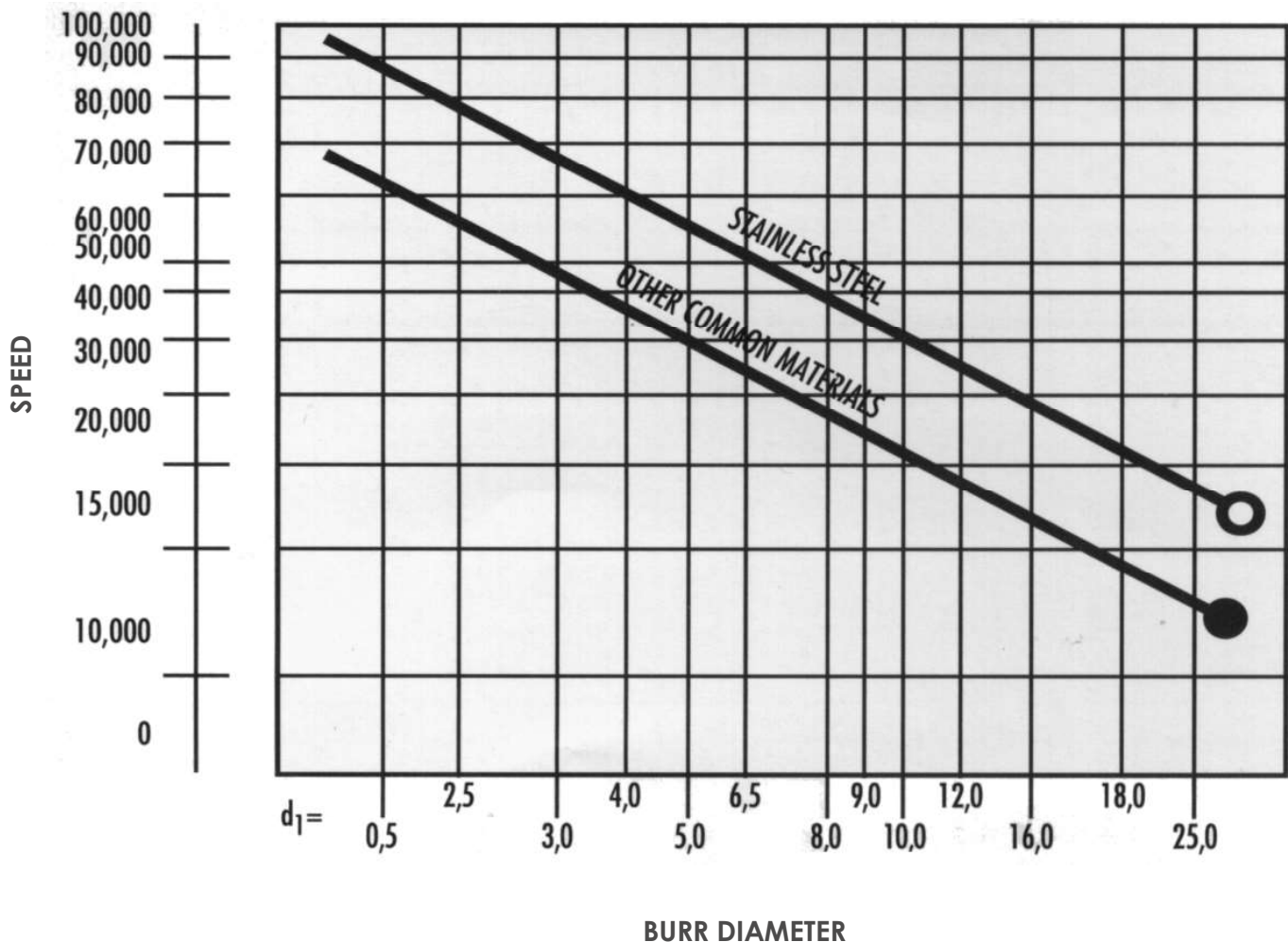



**LARGE 6MM HEADS**



All in this line have a 6mm head diameter	Order Ref.	A0612	B0604	C0612	D0605	E0609	F0612	G0612	M0612	N0606
	Cut Diameter	6.3	6.3	6.3	6.3	6.3	6.3	6.3	6.3	6.3
	Flute Length	12.7	4.7	12.7	5	9.5	12.7	12.7	12.7	6
	Taper								22 deg.	10 deg.
		✓	✓	✓	✓	✓	✓	✓	✓	✓
	Diamond Cut									
	✓	✓	✓	✓	✓	✓	✓	✓	✓	✓

**GRINDING**

**SMALL HEADS**

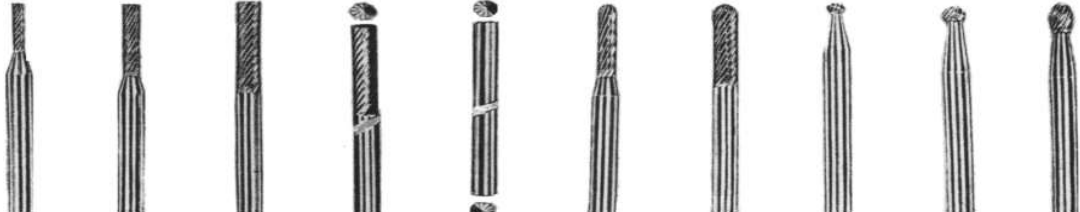

Order Ref.	A0106	A0211	A0314	B0314	B0300	C0211	C0314	D0202	D0303	E0305
Cut Diameter	1.5	2.5	3	3	3	2.5	3	2.5	3	3
Cut Length	6	11	14	14	~	11	14	2.3	2.8	5.5

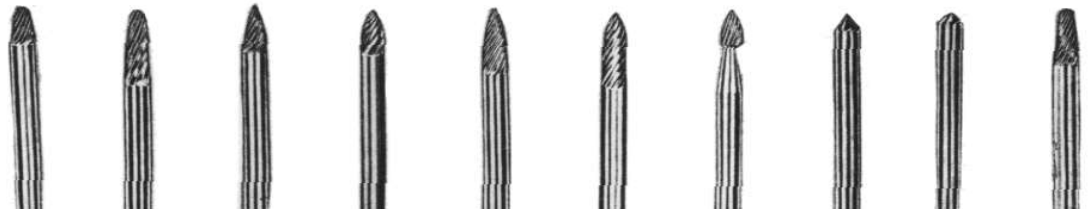

Order Ref.	F0306	F0312	G0306	G0308	G0309	G0312	H0306	J0302	K0301	L0309
Cut Diameter	3	3	3	3	3	3	3	3	3	3
Cut Length	6	12.7	6	8	9.5	12.7	6.3	2.5	1.5	9.5
Taper								60 inc.	90 inc.	

**WHEN ORDERING PLEASE STATE** Reference No, Shank Diameter and Cut Required. Some shapes are available on an extra-long shank i.e 2"-3" overall length.



CARBIDE BURRS - 3MM or 1/8" SP	
Plain or Double Cut	✓
Plain Fine or Double Fine Cut	✓
Diamond or End Cut	✓
ORDER REF - e.g CBA0612	

Order Ref.	L0312	M0308	M0311	M0316	N0203	N0304
Cut Diameter	3	3	3	3	2.5	3
Cut Length	12.7	8.9	11	16	3	4
Taper	8	12	14	7	10	10

Carbide burrs are used for a wide range of stock removal and grinding operations. These small burrs on 2.35mm shanks are particularly suited to small detailed work, consequently they are very popular with jewellers.

They are useful on a wide range of materials, including hard ones such as metal, ceramic, plastics and even wood.

Plain Cut is for general purpose fluting, consequently the second most popular cut. Carbide is commonly used in deburring and for engineering. It offers better long term performance than other materials such as HSS (High Speed Steel).

Carbide burrs need to be used at relatively high speeds. Ideally suited to use with air tools, flexible shaft systems and micromotors.

## MICRO CARBIDE BURRS ON 2.35MM & 1.6MM SHANK

- **TYPE HP** - 2.35mm (3/32'') shank diameter, overall length 45mm
- **ISO No** - Denotes diameter of the carbide head, i.e Fig. 3 ISO-012 = 1.2mm dia.

**WHEN ORDERING, PLEASE STATE WHETHER TYPE FG OR HP SHANK IS REQUIRED & ISO NO/SIZE**

**Micro Carbide Burrs Flat Fissure**

**Micro Carbide Burrs Flat Fissure (Fig. 21)**



MICRO CARBIDE BURRS
SUPPLIED IN PACKS OF 6 ONLY
✓
ORDER NO - CBMCFG



FIG. 1  
ROUND  
Plain Cut

ISO No.	OO2	OO4	OO5	OO7	OO8	OO9	O10	O12	O14	O16	O18	O21
Dia.	0.2mm	0.4mm	0.5mm	0.7mm	0.8mm	0.9mm	1.0mm	1.2mm	1.4mm	1.6mm	1.8mm	2.1mm



FIG. 21  
FLAT FISSURE  
Plain Cut

FIG. 21	ISO No.	OO8	O10	O12	O14	O16	O18	O21
---------	---------	-----	-----	-----	-----	-----	-----	-----

CYLINDER			
Ref.	Head Dia.	Flute length	
A0312	3	12	✓
A0416	4	16	✓
A0616	6	16	✓
A0625	6	25	✓
A0819	8	19	✓
A0919	9.5	19	✓
A0925	9.5	25	✓
A1125	11	25	✓
A1225	12.7	25	✓
A1625	16	25	✓
A1925	19	25	✓
A2525	25	25	✓

CYLINDER



SHAPE A

CYLINDER (END CUT)			
Ref.	Head Dia.	Flute length	
B0312	3	12	✓
B0516	5	16	✓
B0616	6	16	✓
B0625	6	25	✓
B0819	8	19	✓
B0919	9.5	19	✓
B0925	9.5	25	✓
B1125	11	25	✓
B1225	12.7	25	✓
B1625	16	25	✓
B1925	19	25	✓
B2525	25	25	✓

CYLINDER (END CUT)



SHAPE B

CYLINDER (RADIUS)			
Ref.	Head Dia.	Flute length	
C0312	3	12	✓
C0516	5	16	✓
C0616	6	16	✓
C0625	6	25	✓
C0819	8	19	✓
C0919	9.5	19	✓
C0925	9.5	25	✓
C1125	11	25	✓
C1225	12.7	25	✓
C1625	16	25	✓
C1925	19	25	✓
C2525	25	25	✓

CYLINDER (RADIUS)



SHAPE C

OVAL			
Ref.	Head Dia.	Flute length	
E0609	6	9.5	✓
E0916	9.5	16	✓
E1222	12.7	22	✓
E1625	16	25	✓
E1925	19	25	✓

OVAL



SHAPE E

BALL			
Ref.	Head Dia.	Flute length	
D0302	3	2.8	✓
D0503	5	4	✓
D0605	6	5	✓
D0806	8	6.4	✓
D0908	9.5	8	✓
D1109	11	9.5	✓
D1211	12.7	11	✓
D1614	16	14	✓
D1917	19	16	✓
D2524	25	21	✓

BALL



SHAPE D

TREE (RADIUS)			
Ref.	Head Dia.	Flute length	
F0312	3	12.7	✓
F0616	6	16	✓
F0919	9.5	19	✓
F1125	11	25	✓
F1219	12.7	19	✓
F1225	12.7	25	✓
F1625	16	25	✓
F1925	19	25	✓
F1932	19	32	✓
F1934	19	34	✓

TREE (RADIUS)



SHAPE F

TREE (POINTED)			
Ref.	Head Dia.	Flute length	
G0616	6	16	✓
G0819	8	19	✓
G0919	9.5	19	✓
G1219	12.7	19	✓
G1225	12.7	25	✓
G1625	16	25	✓
G1925	19	25	✓
G1938	19	38	✓

TREE (POINTED)



SHAPE G

FLAME			
Ref.	Head Dia.	Flute length	
H0819	8	19	✓
H1232	12.7	32	✓
H1636	16	36	✓
H1941	19	41	✓

FLAME



SHAPE H

GRINDING

### SOLID CARBIDE BURRS

+20% for 'Fine Cut'  
(available with Plain or Double Cut)  
+20% for Diamond Cut

**When ordering, please state:**  
**shank diameter & type of cut required**

60 DEGREE CONE			
Ref.	Head Dia.	Flute length	
J0604	6	4	✓
J0908	9.5	8	✓
J1211	12.7	11	✓
J1614	16	14.5	✓
J1917	19	17.5	✓
J2524	25	24.5	✓

60 DEGREE CONE



J SHAPE

CONE				
Ref.	Head Dia.	Flute Length	Included Angle	
M0619	6	19	14	✓
M0625	6	25	10	✓
M0916	9.5	16	28	✓
M1222	12.7	22	28	✓
M1625	16	25	31	✓

CONE



M SHAPE

90 DEGREE CONE			
Ref.	Head Dia.	Flute length	
K0603	6	3	✓
K0904	9.5	4.7	✓
K1206	12.7	6.3	✓
K1608	16	8	✓
K1909	19	9.5	✓
K2512	25	12.7	✓

90 DEGREE CONE



INVERTED CONE				
Ref.	Head Dia.	Flute Length	Included Angle	
N0909	9.5	9.5	13	✓
N1212	12.7	12.7	28	✓
N1619	16	19	18	✓
N1916	19	16	30	✓

INVERTED CONE



N SHAPE

14 DEGREE TAPER (Radius)			
Ref.	Head Dia.	Flute length	
L0616	6	16	✓
L0822	8	22	✓
L0927	9.5	27	✓
L1228	12.7	28	✓
L1630	16	30	✓
L1938	19	38	✓

14 DEGREE TAPER (RADIUS)



L SHAPE

### SOLID CARBIDE BURRS

+10% for 'Fine Cut'  
(available with Plain or Double Cut)  
+20% for Diamond Cut

**When ordering, please state:  
shank diameter & type of cut required**

### CARBIDE BURRS FOR ALUMINIUM & PLASTICS, COPPER, BRASS

These burrs have a special cut which has been made for Alloys

- Reduce the amount of clogging
- Longer lasting burrs
- Smoother running
- Small heads on a 3mm spindle
- Cutting speeds recommended at 400 to 1000m/min
- Burrs are sold each – delivery may take a maximum of 7 days



### END MILLS & COUNTERSINKS

#### MICROGRAIN (METRIC) SOLID CARBIDE END MILLS



#### SOLID CARBIDE COUNTERSINKS



#### SOLID CARBIDE JIG BORING TOOLS





## PREMIUM CARBIDE BURR SETS

Great value, premium carbide burr sets. These sets offer various shapes all on a 3mm spindle.

Carbide is commonly used in deburring and for engineering. It offers better long-term performance than other materials such as HSS (High-Speed Steel).

Small Head – Set of 10, 10 variations.  
Large Head – Set of 10, 5 variations.  
Alumina Cut – Set of 10



PREMIUM CARBIDE BURR SETS		
Size		CODE
Small Head	✓	CBSETBH-3MM
Large Head	✓	CBSETBH-3MM
Alumina Cut	✓	Call to ask for details

## JIG & INTERNAL PRECISION GRINDING PINS

### BORAZON (CBN) OR DIAMOND

**Borazon Pins-** Used on tough, high carbon and high chrome M&T series steels, as well as high nickel and cobalt alloys.

**Diamond Pins-** Used on carbide, ceramics, sapphire and glass, as well as tough, super alloys and reinforced plastics.

OTHER SIZES AND SHAPES NOW AVAILABLE UP TO 15MM DIA & ALSO IN BALL, CONE AND TAPER SHAPES IN COARSE, MEDIUM AND FINE. ASK FOR DETAILS.

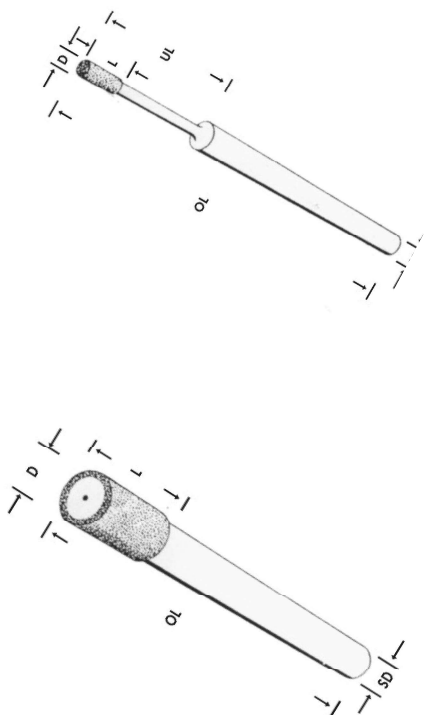

GRINDING PINS						
Diameter (mm)	Shank Diameter (mm)	L (mm)	UL (mm)	OL (mm)	Minimum Order Qty.	
0.4	3.0	2	3	46	2 off	✓
0.5	3.0	3	3	46	2 off	✓
0.6	3.0	3	3	46		
0.7	3.0	2	2	40		
0.8	3.0	4	6	46	2 off	✓
1.0	3.0	5	9	55		
1.5	3.0	5	13	55		
2.0	3.0	5	17	55	2 off	✓
2.5	3.0	4	19	55		
3.0	3.0	6	22	55		
3.5	3.0	6		55	2 off	✓
4.0	3.0	6		55		
5.0	3.0	6		55		
6.0	3.0	6		55	2 off	✓
8.0	6.0	6		66		
10.0	6.0	10		60		
12.0	6.0	10		60	1 off	✓
15.0	6.0	10		60		

ORDER REF - PINS

## HP DIAMOND POINTS ON 2.35MM SHANK

- N.B where the ISO reference numbers are given, the last three digits (in bold type) indicate the nominal maximum head dimension. Eg. 196/016 - 1.6mm diameter
- 2.35mm shank - Exact sizes illustrated

GRINDING

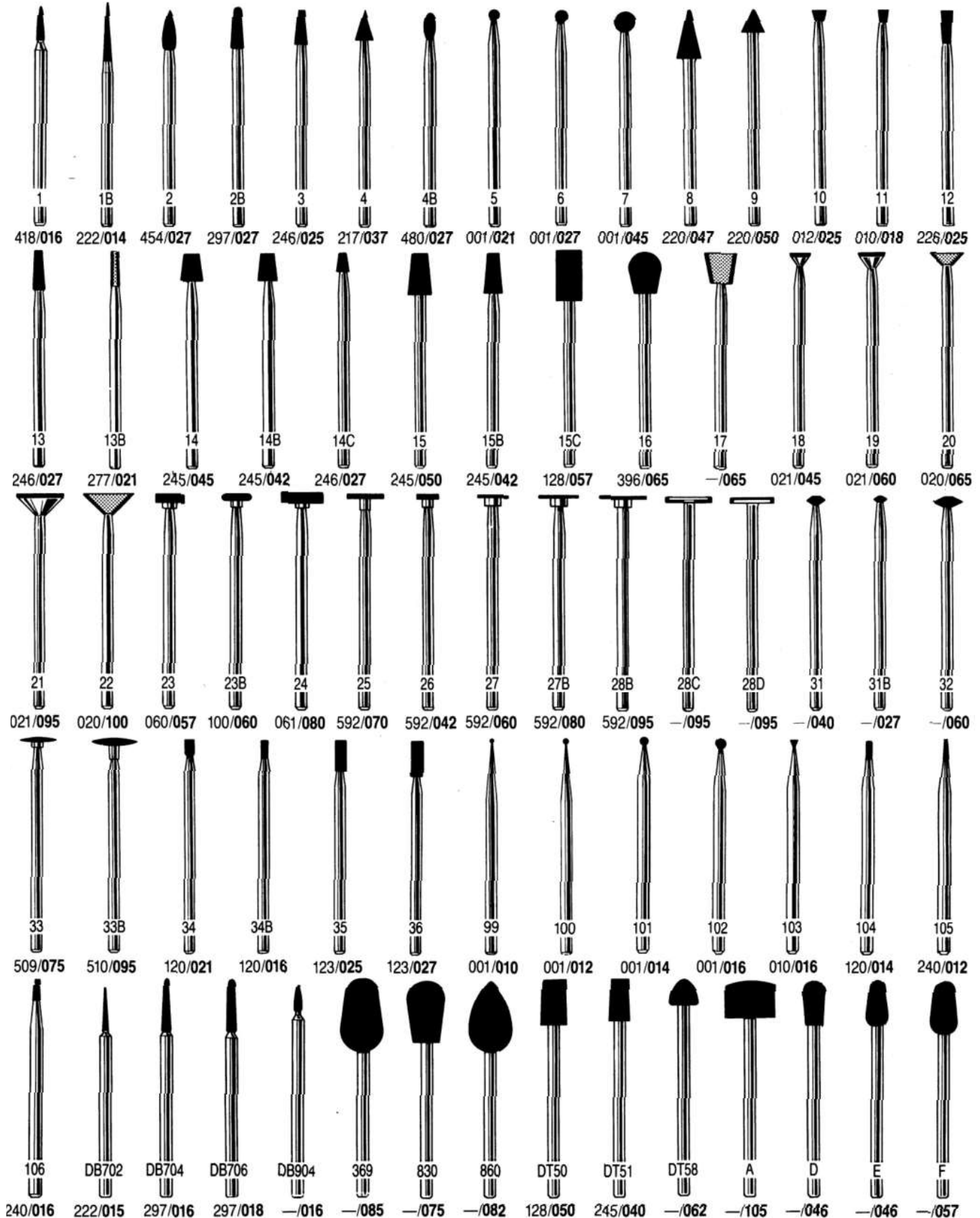

## FG DIAMOND POINTS ON 1.6MM SHANK

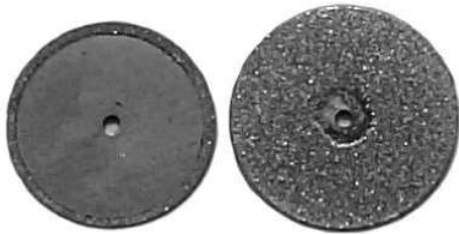
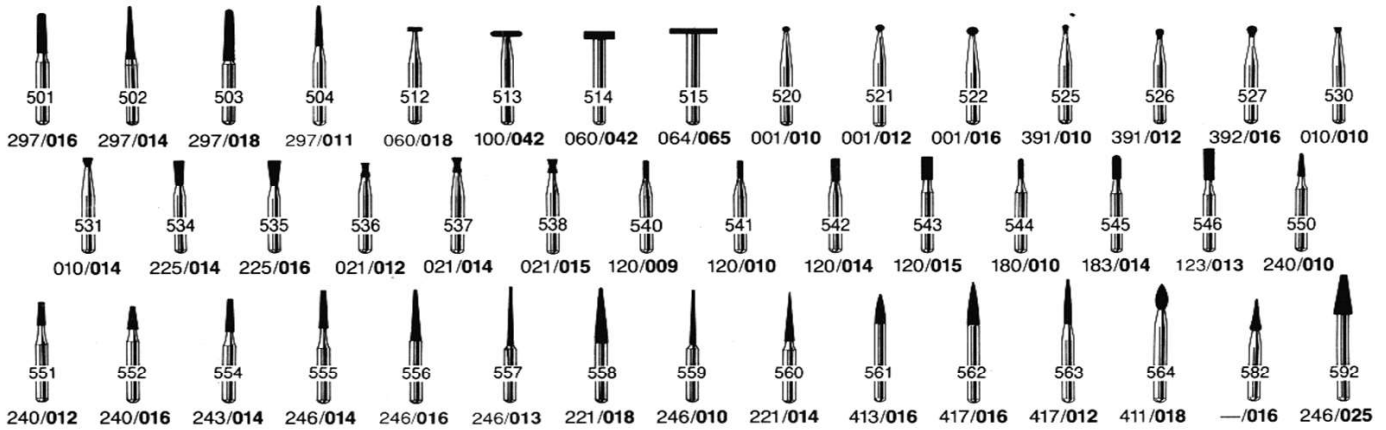

### DIAMOND SLOT WHEELS

- **88D** - Diamond on the rim only
- **88DC** - Diamond fully coated
- **88DCHD** - Fully coated heavy duty

Available in:  
20, 25, 30, 40, 50, 65, 75, 100, 125  
and 150mm diameters.

SLOT WHEELS	
Order Ref - Size	
<b>88D</b> 22mm dia x 0.6mm	✓
<b>88DC</b> 22mm dia x 0.6mm	✓
<b>88DCHD</b> 25mm dia x 0.6mm	✓
ORDER REF - DIAMONDWHEEL..	

FG DIAMOND POINTS - 1.6mm dia shank	
Ref.	
501, 502, 503, 504, 512, 520, 521, 522, 525, 526, 527, 530, 531, 534, 535, 536, 537, 538, 540, 541, 542, 543, 545, 546, 550, 551, 552, 554, 555, 556, 557, 558, 559, 560, 561, 562, 563, 564, 582	✓ Minimum order 5 of one type
513, 514, 515, 518, 592	✓
ORDER REF - DPFPG...	

HP DIAMOND POINTS - 2.35mm dia shank	
Ref.	
1, 1B, 2, 2B, 3, 5, 6, 10, 11, 13, 13B, 34, 34B, 99, 100, 101, 102, 103, 104, 105, 106, DB702, DB704, DB706, DB904	✓ Minimum order 5 of one type
4B, 7, 14, 14B, 14C, 18, 19, 26, 31, 31B, 32, 35, 36	✓
4, 9, 15, 15B, 15C, 20, 24, 28B, 28D, 33, D, E, DT50, DT51, DT58	✓
8, 16, 17, 21, 22, 23, 23B, 25, 27, 27B, F, 33B, 369, 830, 860	✓
A	✓
ORDER REF - DPHP...	

GRINDING

### MM304DM WHEEL MANDREL

3mm shank



<b>304DM</b>
✓
ORDER REF - MM304DM

### MM503 SCREW TOP MANDREL

2.35mm or 3mm shank



<b>503 MANDREL</b>
✓
ORDER REF - MM503

### FG COLLET REDUCER

2.35mm shank, down to a 1.6mm



<b>FG COLLET REDUCER</b>
✓
ORDER REF - DPFGCOLLETHOLDER

# DIAMOND POINT SETS & DIAMOND DRESSERS



## 20 PIECE DIAMOND POINT SET

- 2.35mm Shank
- 20 Piece Set



20 PIECE SET-2.35MM SP



ORDER REF - DPSET-2.35-M-20P

## 30 PIECE DIAMOND POINT SET

- 3mm Shank
- 30 Piece Set



30 PIECE 3MM SP



ORDER REF -  
DPSET-3MM-MIXEDH-BQ

GRINDING

## DIAMOND POINTS

For working on all metals, alloys, steel & precious metals as well as plastics & ceramics - On a 3mm shank

Sold Individually



## BM DIAMOND POINTS ON 3MM

REF.		REF.	
BM 25B	✓	BM 30A	✓
BM 40B	✓	BM 50A	✓
BM 50B	✓	BM 30C	✓
BM 20F	✓	BM 40C	✓
BM 20P	✓	BM 50C	✓
BM 20R	✓	BM 50F	✓
BM 30P	✓	BM 60P	✓
BM 10C	✓	BM 130X	✓
BM 20A	✓	Max RPM 40,000	

ORDER REF - DPBM...

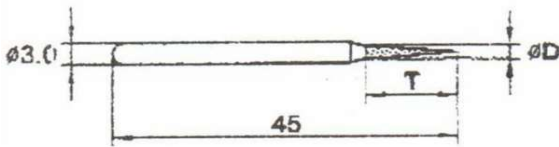

NO	BM 25B	BM 40B	BM 50B	BM 20F	BM 20P	BM 20R	BM 30P	BM 10C	BM 20A	BM 30A	BM 50A	BM 30C	BM 40C	BM 50C	BM 50F	BM 60P	BM 130X
D (MM)	2.5	4	4.8	2	2	2	3	1	2	3	5	3	4	5	5	6	13
T (MM)	~	~	~	10	12	12	15	10	8	10	10	10	10	10	10	13	2

WE WOULD BE VERY PLEASED TO QUOTE YOU FOR ALL NON-STANDARD CHISELS AND DRESSERS. SPECIALIST DESIGN OF TOOLS UNDERTAKEN.



## SINGLE POINT DIAMOND DRESSERS

English manufacture - Excellent quality

- One carat diamond
- 3/8 x 4" or 1/2 x 4"

Sold Per Dresser

## DIAMOND CHISELS & DRESSERS

### STANDARD CHISELS

60 or 40 deg. x .005" - .015"

60 or 40 deg. x .020"

30 deg x .005" - .020"



### RADIUS FORMING CHISELS - DIAFORM, etc

60 or 40 deg. x .005" - .015"

60 or 40 deg. x .020"

30 deg. x .005" - .020"



### SINGLE POINT DIAMOND DRESSERS

3/8 x 4" or 1/2 x 4"



ORDER REF - DTSPD OR DC





MINIMAT & MAXIMAT FLICK WHEELS

Minimat wheels are used with a pendant drill or micromotor. For adding decorative satin finishes to metal, particularly precious and soft metals.

Maximat wheels are used with a bench polisher with tapers. For adding decorative satin finishes to metal, particularly precious and soft metals.

- Blue 0.2mm Fine
- Red 0.3mm Medium
- Yellow 0.45mm Coarse
- Green 0.6mm V.Coarse

Sold Individually - Refills Available

MAXIMAT & MINIMAT FLICK WHEELS		
TYPE		ORDER REF + GRADE
Complete MINIMAT	✓	FLICKWHEELMINI
Minimat Mandrel	✓	FLICKWHEEL-MINI-MANDREL
Minimat Core/Hub	✓	FLICKWHEEL-MINI-COREHUB
Minimat Refills	✓	FLICKWHEELMINIREFILL
Complete MAXIMAT	✓	FLICKWHEELMAXI
Maximat Refills	✓	FLICKWHEELMAXIREFILL



GRINDING

SMALL MOUNTED CUPS, WHEELS & PENCILS

Brass, Steel, Bristle, Hair and Nylon. These points are particularly useful for detail polishing & deburring

Sold Per 10



2.35MM SPINDLE	WHEELS		CUPS		PENCILS	
Material	19mm	22mm	10mm	12mm	4.5mm	6mm
Brass, Fine	X	✓	X	✓	✓	✓
Steel, Fine	X	✓	✓	✓	✓	X
Stainless Steel	X	✓	X	X	✓	X
ORDER REF - VSM- (OR SM-)						
3MM SPINDLE	WHEELS		CUPS		PENCILS	
Material	20mm	25mm	12 x 3mm	15 x 8mm	5 x 6mm	6 x 8mm
Brass		✓	X	X	✓	✓
Steel		✓	✓	X	X	✓
ORDER REF - VSM3MM						

FOR POLISHING BRISTLE AND HAIR WHEELS, CUPS AND PENCILS PLEASE SEE PAGE 107

MOUNTED WIRE WHEELS & PENCILS

A useful range of mounted wire brushes for deburring or rust removal.

Note- 9040 range specifically for lighter use to fit into a power drill. All are on a **6mm shaft**.

Sold Individually.



MTD WHEELS & PENCILS			
Part No.	Type	Size (mm)	
SES-02	Pencil	6	✓
SES-04	Pencil	12	✓
SWAS-12	Wheel	30 X 8	✓
SWAS-20	Wheel	50 X 12	✓
ORDER REF - WWUNION			

# VITRIFIED MOUNTED B & A SHAPE POINTS

GRINDING

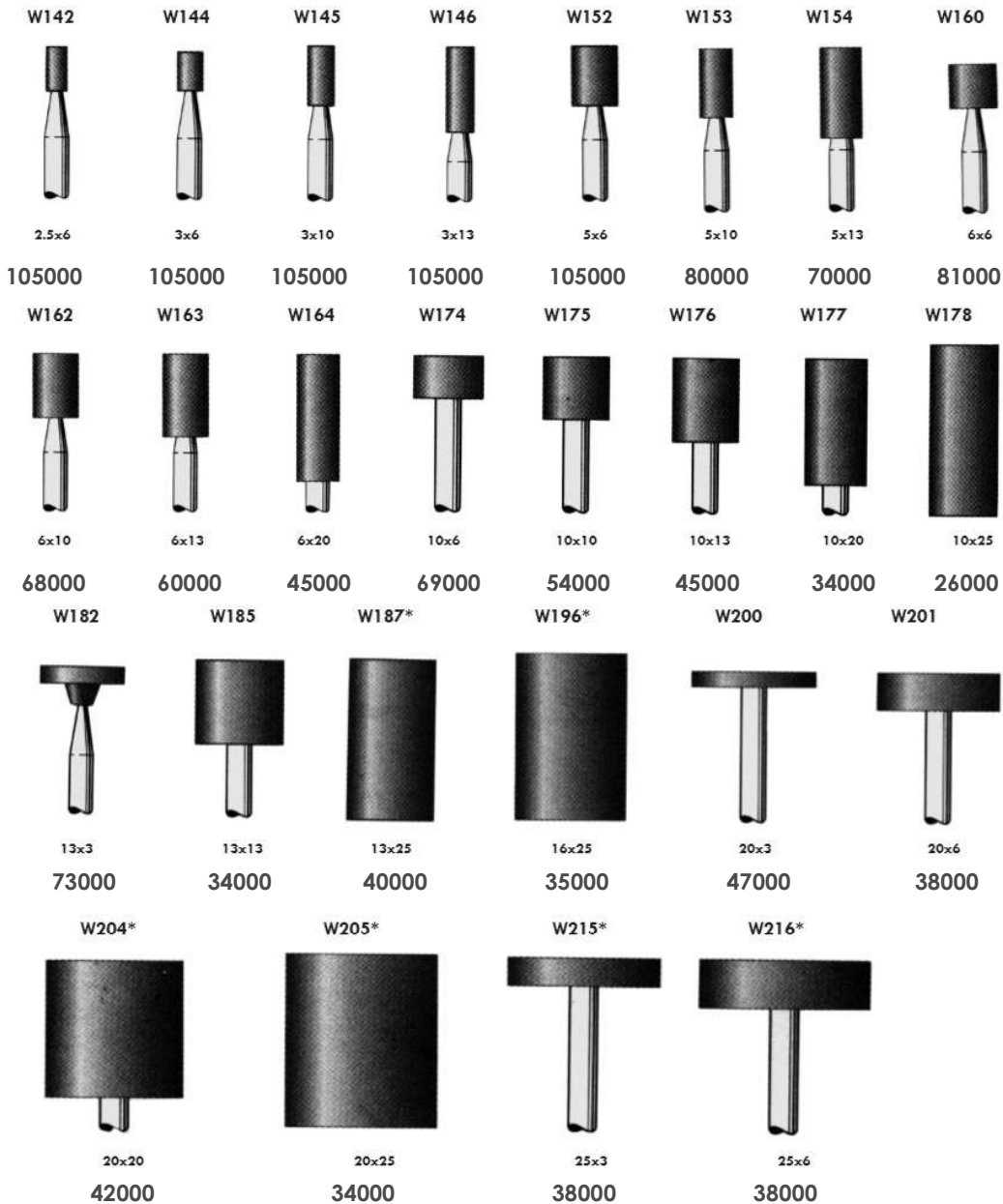

W-SHAPE POINTS	
ORDER REF	
W142	✓
W144	✓
W145	✓
W146	✓
W152	✓
W153	✓
W154	✓
W160	✓
W162	✓
W163	✓
W164	✓
W170	✓
W174	✓
W175	✓
W176	✓
W177	✓
W178	✓
W179*	✓
W182	✓
W185	✓
W187*	✓
W188*	✓
W196*	✓
W197*	✓
W200	✓
W201	✓
W204*	✓
W205*	✓
W208*	✓
W215	✓
W216*	✓
W220*	✓
W222*	✓
W225*	✓
W226*	✓
W227*	✓
W235*	✓
W236*	✓
W238*	✓
W242*	✓

## MOUNTED VITRIFIED POINTS W-SHAPE

- Not all shapes are available in all grades.
- Metric and imperial shank sizes.
- \*large dia. on 6mm or 1/4" shank only.

Sold in Packs of 10

Other 'W' Shapes available, not illustrated above					
ORDER REF	Size	Max.rpm	Point No.	Size	Max.rpm
W170	8x13	45000	W225*	32x6	29000
W179*	10x32	45000	W226*	32x10	29000
W188*	13x38	30000	W227*	32x13	30000
W197*	16x50	21000	W235*	38x6	25000
W208*	20x50	18000	W236*	38x13	25000
W220*	25x25	25000	W238*	38x38	15000
W222*	25x50	15000	W242*	50x25	19000

**PINK:** The most popular. Aluminium Oxide, with low/medium Chromium Oxide content. Fine finish. Hard – retains shape longer.

**RUBY:** Aluminium Oxide, with high Chromium Oxide content. Generally coarser grit than Blue. Excellent stock removal on die work, castings and general grinding and deburring.

**BLUE:** Aluminium Oxide. A finer grit. General work with a low to medium stock removal to produce a good surface finish.



B-SHAPE POINTS	
ORDER REF	
B41	✓
B42	✓
B43	✓
B44	✓
B45	✓
B46	✓
B47	✓
B51	✓
B52	✓
B53	✓
B54	✓
B55	✓
B62	✓
B63	✓
B64	✓
B65	✓
B71	✗
B72	✓
B73	✓
B74	✓
B81	✓
B91	✓
B92	✓
B93	✓
B95	✓
B96	✓
B97	✓
B98	✓
B103	✓
B104	✓
B105	✓
B106	✓
B111	✓
B112	✓
B113	✓
B114	✓
B115	✓
B121	✓
B122	✓
B123	✓
B124	✓
B125	✓
B131	✓
B132	✓
B133	✓
B134	✓
B135	✓
B136	✓

B41	B42	B43	B44	B45	B46	B47	B51	B52	B53	B54			
16x16	13x20	6x8	6x10	5x8	4x8	4x4	11x20	10x20	8x20	6x13			
33000	33000	81000	68000	104000	105000	105000	45000	45000	45000	60000			
B55	B62	B63	B64	B65	B71	B72	B73	B74	B81	B91			
3x6	13x10	6x5	6x3	3x3	16x4	13x4	13x4	5x2	20x5	13x16			
105000	41000	92000	105000	105000	60000	73000	73000	105000	48000	34000			
B92	B93	B95	B96	B97	B98	B103	B104	B105	B106	B111	B112		
6x6	5x5	3x5	3x6	4x10	4x6	16x6	8x10	6x6	3x3	10x20	10x13		
81000	105000	105000	105000	105000	105000	59000	68000	104000	105000	33000	45000		
B113	B114	B115	B121	B122	B123	B124	B125	B131	B132	B133	B134	B135	B136
6x6	5x9	2x3	13∅	10∅	5∅	3∅	6∅	13x13	10x13	10x10	8x9	6x13	6x8
81000	68000	105000	45000	61000	104000	105000	81000	34000	45000	54000	61000	60000	70000
A2	A4	A5	A12	A13	A14	A15	A21						
25x32	32x32	20x28	20x32	30x32	20x22	6.5x27	25x25						
38000	30000	45000	48000	33000	53000	72000	34000						
A23	A24	A25	A26	A32	A33	A37	A38	A39					
20x25	6.5x20	25∅	16∅	25x19	25x13	30x7	25x25	20x20					
39000	76000	35000	60000	38000	38000	30000	34000	47000					



Max safe working speed displayed below size (RPM)

'B' SHAPES  
1/8" or 3mm shank

'A' Shapes  
1/4" or 6mm shank

A-SHAPE POINTS	
ORDER REF	
A2	✓
A4	✓
A5	✓
A12	✓
A13	✓
A14	✓
A15	✓
A21	✓

A-SHAPE POINTS	
ORDER REF	
A23	✓
A24	✓
A25	✓
A26	✓
A32	✓
A33	✓
A37	✓
A38	✓
A39	✓

GRINDING

## MOUNTED PINK POINTS IN QUANTITY

A selected range of pink mounted points on 3mm shanks at incredibly low prices, for those who buy in quantity. Please note these quantities may be subject to long lead times. Please enquire for more information.

### Sold Per Quantity



MTD PINK POINTS IN QUANTITY				
ORDER REF		Quantity Discount		
		200+	500+	1000+
W142	✓	-20%	-25%	-30%
W144	✓			
W145	✓			
W146	✓			
W153	✓			
W154	✓			
W163	✓			
W164	✓			
W170	✓			
W176	✓			
B44	✓			
B52	✓			
B53	✓			
B55	✓			
B97	✓			
B122	✓			
B123	✓			

Discounted prices based on orders of one size only, not a mixture

GRINDING

## MOUNTED POINT SET

A mixture of shapes and grades from our comprehensive range. Sets available on 1/8" or 3mm spindles. Please state which you require.



MTD POINT SET	
SPINDLE	
3mm	✓
1/8"	
ORDER REF - MPSET	

## MOUNTED PINK POINTS ON 2.35MM

A range of shapes on a 2.35mm spindle. Ideal for Jewellers, the smaller spindle allows for smaller heads.

### Sold Individually



W163 A80-GFX 60,000	B123 104,000	W163 60,000	B53 60,000	W176 45,000
W163 A50-MCFlex 60,000	W144 105,000	B185 60,000	B44 68,000	B103 59,000
	B57 105,000	W163 80,000		

(RPM - Maximum safe operating speeds at 13mm overhang)  
(not drawn to scale)

PINK POINTS ON 2.35MM				
SHAPE	HEAD DIMENSIONS	GRIT SIZE		ORDER REF
CYLINDER	2 X 5mm	120g	✓	O542101
	4 X 8mm	80g	✓	O542103
	6 X 10mm	80g	✓	O542105
CONE	6 X 10mm	100g	✓	O542118
SPHERE	5mm	100g	✓	O542114
	8mm	80g	✓	O542115

ORDER REF - JOKE-(REF)



## MICROPOINTS

- Micropoints have been introduced to provide a precision small finishing point for fine finishing and the ability to dress to a shape.
- On a 3mm shank.
- 1.7mm head diameter.
- Aluminium Oxide 320g , very hard vitrified bond giving long life and keeping their form.
- Colour may vary, blue is medium and white is fine. Please state when ordering if you have a preference.



MICROPOINTS per 10	
<b>PREMIUM WHITE</b>	✓
<b>ORDER REF - MICROPOINTS</b>	

**Sold in Packs of 10**

## 1MM MICRO GRINDING POINTS

- The smallest points on the market.
- With a head diameter of 1mm (x 7mm) on a 3mm shank.
- Pink Aluminium Oxide.



1MM GRINDING POINTS	
<b>HEAD SIZE</b>	
<b>1mm X 7mm</b>	✓
<b>ORDER REF - MICROPOINTS-1MM</b>	

**Sold Individually**

GRINDING

## X-TRA CUT POINTS

X-TRA CUT, long life, mounted points comprise a premium aluminium oxide in a medium/hard bond. These points provide superior cutting for fast stock removal.

X-TRA CUT points run cooler and last 2-3 times longer than standard mounted points. Other grades of fast cutting points are soft and have rapid wear.

Each point is securely bonded and trued and can be accurately dressed using the "truing" stone below.

**Sold in Packs of 10**

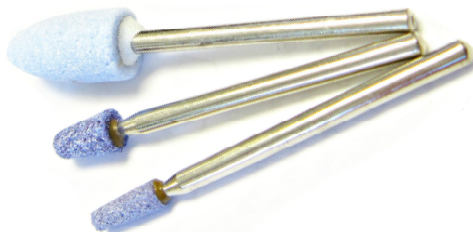

X-TRA CUT MTD POINTS x 1/8" shank		
ORDER REF	Size (mm)	
<b>XC-W142</b>	2.5 x 6	✓
<b>XC-W145</b>	3 x 10	✓
<b>XC-W153</b>	5 x 10	✓
<b>XC-W160</b>	6 x 6	✓
<b>XC-W163</b>	6 x 13	✓
<b>XC-W170</b>	8 x 13	✓
<b>XC-W185</b>	13 x 13	✓
<b>XC-B44</b>	6 x 10	✓
<b>XC-B52</b>	10 x 20	✓
<b>XC-B97</b>	4 x 10	✓
<b>XC-B122</b>	10 dia	✓
<b>XC-B124</b>	3 dia	✓
<b>XC-B125</b>	6 dia	✓

## TRUING STONE

Used to dress, shape and clean mounted points. Quickly resurfaces points back to 'like new' condition.



TRUING STONE	
<b>TR-1 Each</b>	✓
<b>ORDER REF - XC-TRUINGSTONE</b>	

## DIAMOND DEBURRING TOOL

Manual and machine use (drills, machining centres, special-purpose machines).

This product has a wide range of uses, even on hard materials, such as deburring and chamfering cross holes, deburring deep blind holes.



DIAMOND DEBURRING TOOL		
ORDER REF.	Size (mm)	
JOKE-0564212	1.9	✓
JOKE-0564214	2	✓
JOKE-0564224	3	✓
JOKE-0564234	4	✓
JOKE-0564244	5	✓
JOKE-0564254	6	✓
JOKE-0564264	8	✓

## XEBEC EXTENDED DEBURRING TOOL

These new little grinding points are perfectly suited to accurate precision deburring of cross holes. The 40mm long elastic shaft reduces the risk of breakage during use. The special aluminium oxide material ensures continually high grinding performance. They have a self sharpening cutting edge that remains completely free of grinding dust.

Sold Individually

GRINDING



XEBEC EXTENDED DEBURRING TOOL				
SIZE	SHAPE	GRIT	MAX RPM	
3mm	CYLINDER (HR) & BALL (HB)	Grey 220g Orange 400g Blue 800g	10,000rpm	✓
4mm	CYLINDER (HR) & BALL (HB)		10,000rpm	✓
5mm	CYLINDER (HR) & BALL (HB)		8,000 rpm	✓
6mm	BALL (HB) ONLY		8,000 rpm	✓
10mm	BALL (HB) ONLY	220g (grey) only	6,000 rpm	✓

ORDER REF - XEBEC-HR/HB

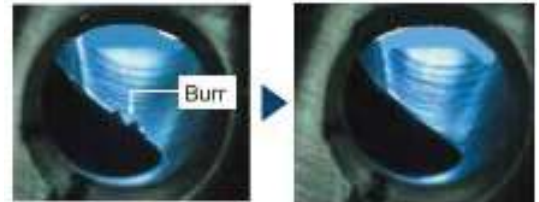
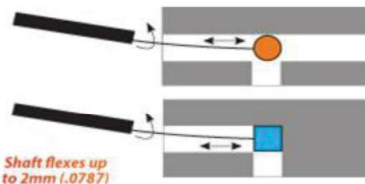
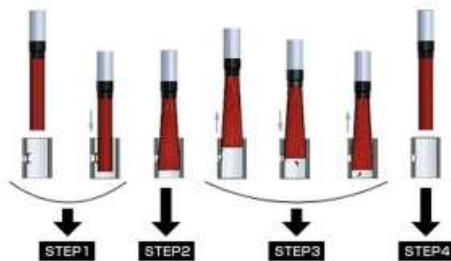

**STEP 1** Insert the tool whilst not in motion

**STEP 2** Rotate the tool past the cross-hole

**STEP 3** Work the brush back and forth while rotating

**STEP 4** Pull the tool out whilst not in motion

## XEBEC CROSS HOLE DEBURRING BRUSHES

Using the centrifugal force generated by rotation, the brush tip deburrs and creates a finished edge.

Can be used in rotary tools as well as mounted in CNC machines capable of 8000 min-1 upwards.

Use at 7,000-12,000 min-1

Sold Individually

XEBEC BRUSH - CROSSHOLE						
Grade	Target Dia. Primary Hole	Length	Brush Dia.	Shaft Dia.	Shank Dia.	ORDER REF
RED A12	3.5~5 mm	120mm	1.5 mm	2.5mm	3mm	✓ CH-A12-1.5M
	5~8 mm		3 mm	4mm	3mm	✓ CH-A12-3M
	8~10 mm		5mm	6mm	6mm	✓ CH-A12-5M
	10~20 mm	170mm	7mm	8mm	6mm	✓ CH-A12-7M
	5~8 mm		3mm	4mm	4mm	✓ CH-A12-3L
	8~10 mm		5mm	6mm	6mm	✓ CH-A12-5L
	10~20 mm		7mm	8mm	6mm	✓ CH-A12-7L
BLUE A33	5~8 mm	130mm	3mm	4mm	3mm	✓ CH-A33-3M
	8~10 mm		5mm	6mm	6mm	✓ CH-A33-5M
	10~14 mm		7mm	8mm	6mm	✓ CH-A33-7M
	14~20 mm	180mm	11mm	12mm	12mm	✓ CH-A33-11M
	5~8 mm		3mm	4mm	4mm	✓ CH-A33-3L
	8~10 mm		5mm	6mm	6mm	✓ CH-A33-5L
	10~14 mm		7mm	8mm	8mm	✓ CH-A33-7L
	14~20 mm		11mm	12mm	12mm	✓ CH-A33-11L

ORDER REF - XEBEC-CH....

## ABRASIVE SPIRABANDS

Resin Bond Aluminium Oxide Cloth, spiral wound with interlinking cloth to create a perfectly smooth running condition.

**SPIRABANDS - Sold Per 100**

### Grit Types Available:

Aluminium Oxide  
Blue Zirconia

### Grits Available:

**50, 80, 150g**

(Other grits available on application)



### SPIRABAND HOLDERS

Either on a 6mm or 8mm spindle.  
Select a holder to fit the bands used.  
**Sold Each**



**TRIZACT BANDS**  
A16 & A6 7 x 13mm  
**Sold Per 10**

**ALSO AVAILABLE**  
25 x 25, 38 x 25, 50 x 30, 51 x 25  
in A16, A30, A45

### NEW DIAMOND GRADES

D20 TO D250 - 15 X 30 + 22X20  
Please Ask For Details

SPIRABANDS		
REF	Dia x Length (mm)	
Aluminium Oxide		
SP1010	10 x 10	✓
SP1020	10 x 20	✓
SP1310	13 x 10	✓
SP1325	13 x 25	✓
SP1510	15 x 10	✓
SP1530	15 x 30	✓
SP1925	19 x 25	✓
SP2220	22 x 20	✓
SP2525	25 x 25	✓
SP3020	30 x 20	✓
SP3030	30 x 30	✓
SP3825	38 x 25	✓
SP4530	45 x 30	✓
SP5125	51 x 25	✓
SP6030	60 x 30	✓
SP7530	75 x 30	✓
SP10040	100 x 40	✓

**ORDER REF - MSP(REF No)-(GRIT)**

GRINDING

SPIRABAND HOLDERS				
REF	Dia x Length (mm)	Shank	Max. RPM	
RH0713	7 x 13	1/8"	38,000	✓
AJCM7F	7 x 13	3mm	~	✓
RH1010	10 x 10	6mm	38,000	✓
RH1020	10 x 20		38,000	✓
RH1310	13 x 10		30,000	✓
RH1325	13 x 25		30,000	✓
RH1510	15 x 10		26,000	✓
RH1530	15 x 30		26,000	✓
RH1925	19 x 25		20,000	✓
RH2220	22 x 20		17,000	✓
RH2525	25 x 25		15,000	✓
RH3020	30 x 20		13,000	✓
RH3030	30 x 30		13,000	✓
RH3825	38 x 25		10,000	✓
RH4530	45 x 30		8,500	✓
RH5125	51 x 25		7,500	✓
RH6030	60 x 30		6,500	✓
RH7530	75 x 30		8mm	5,000
RH10040	100 x 40	4,000		✓

**ORDER REF - MRH(REF No)**

## ABRASIVE JIFFY CAPS

JIFFY CAPS are a coated abrasive product, manufactured without seams and are mounted on a suitably-shaped rubber mandrel. The caps are firmly held and can be easily changed. The rubber JIFFY CAP system provides a more flexible fine grinding head than conventional Bonded Mounted Points.

### GRITS AVAILABLE

Brown

Aluminium oxide (good on steels) 80g Coarse, 150g Medium, 320g Fine

60g Coarse, 80g Medium, 150g Fine

COLOURS MAY VARY BETWEEN BROWN & GREEN

### Recommended Max Speeds:

5mm dia.	:	45,000 rpm
7mm dia.	:	32,000 rpm
10mm dia.	:	22,000 rpm
13mm dia.	:	17,000 rpm
16mm dia.	:	14,000 rpm

### Mandrels available on 3mm or 1/8" spindles

When ordering please state Ref, Grit, Colour, (Caps) and Shank Diameter (Mandrels)

GRINDING

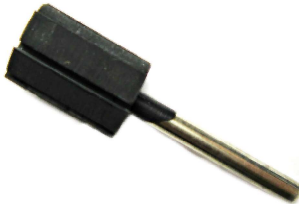

#### FLAT MANDRELS

ORDER REF.	Size (mm)	
AJCM5F	5 X 10	✓
AJCM7F	7 X 12	✓
AJCM10F	10 X 15	✓
AJCM13F	13 X 19	✓
AJCM16F	16 X 26	✓

#### ROUND MANDRELS

ORDER REF.	Size (mm)	
AJCM5R	5 X 11	✓
AJCM7R	7 X 13	✓
AJCM10R	10 X 15	✓
AJCM13R	13 X 19	✓
AJCM16R	16 X 26	✓

#### CONE MANDRELS

ORDER REF.	Size (mm)	
AJCM5C	5 X 11	✓
AJCM7C	7 X 13	✓
AJCM10C	10 X 15	✓
AJCM13C	13 X 19	✓
AJCM16C	16 X 26	✓



### ABRASIVE CAPS PER 100

#### FLAT CAPS

ORDER REF.	Size (mm)	Brown
AJC5F	5 X 10	✓
AJC7F	7 X 12	✓
AJC10F	10 X 15	✓
AJC13F	13 X 19	✓
AJC16F	16 X 26	✓

#### ROUND CAPS

ORDER REF.	Size (mm)	Brown
AJC5R	5 X 11	✓
AJC7R	7 X 13	✓
AJC10R	10 X 15	✓
AJC13R	13 X 19	✓
AJC16R	16 X 26	✓

#### CONE CAPS

ORDER REF.	Size (mm)	Brown
AJC5C	5 X 11	✓
AJC7C	7 X 13	✓
AJC10C	10 X 15	✓
AJC13C	13 X 19	✓
AJC16C	16 X 26	✓



## MOUNTED STANDARD ABRASIVE FLAP WHEELS

Abrasive flap wheels mounted on either a 3mm or 6mm spindle.

- Prices shown for Aluminium Oxide grit.
- Ceramic, Diamond, Trizact and Zirconia also available

**Sold in Packs of 10**



## GRIT SIZES AVAILABLE AS STANDARD

**40 - 60 - 80 - 120**

Other grits available  
100 - 150 - 180 - 240 - 320



## TRIZACT FLAP WHEELS

30 x 30 - 6mm  
50 x 30 - 6mm

Both in grades for super finishing on stainless and tool steels.

A16 equivalent to 1200 grit  
A30 equivalent to 600 grit  
A45 equivalent to 400 grit  
Ref: MFWT SIZE + GRIT

MTD ABRASIVE FLAP WHEELS				
PART NO.	Dia x Length	Shank Dia.	Max. RPM	
<b>ALUMINIUM OXIDE</b>				
<b>MTD MINI FLAP WHEELS</b>				
<b>MFW1010</b>	10 x 10	3mm	40,000	✓
<b>MFW1515</b>	15 x 15	3mm	40,000	✓
<b>MTD STANDARD FLAP WHEELS</b>				
<b>MFW2005</b>	20 x 5	3mm	30,000	✓
<b>MFW2010</b>	20 x 10	3mm	30,000	✓
<b>FW2210</b>	22 x 10	6	25,000	✓
<b>FW2215</b>	22 x 15	6	25,000	✓
<b>FW2220</b>	22 x 20	6	25,000	✓
<b>FW2505</b>	25 x 5	3~6	25,000	✓
<b>FW2510</b>	25 x 10	3~6	25,000	✓
<b>FW2515</b>	25 x 15	3~6	25,000	✓
<b>FW2520</b>	25 x 20	3~6	25,000	✓
<b>FW2525</b>	25 x 25	3~6	25,000	✓
<b>FW3005</b>	30 x 5	3~6	22,000	✓
<b>FW3010</b>	30 x 10	3~6	22,000	✓
<b>FW3015</b>	30 x 15	3~6	22,000	✓
<b>FW3020</b>	30 x 20	3~6	22,000	✓
<b>FW3025</b>	30 x 25	3~6	22,000	✓
<b>FW4010</b>	40 x 10	6	16,000	✓
<b>FW4015</b>	40 x 15	6	16,000	✓
<b>FW4020</b>	40 x 20	6	16,000	✓
<b>FW4025</b>	40 x 25	6	16,000	✓
<b>FW4030</b>	40 x 30	6	16,000	✓
<b>FW5010</b>	50 x 10	6	13,000	✓
<b>FW5020</b>	50 x 20	6	13,000	✓
<b>FW5025</b>	50 x 25	6	13,000	✓
<b>FW5030</b>	50 x 30	6	13,000	✓
<b>FW5040</b>	50 x 40	6	13,000	✓
<b>FW6015</b>	60 x 15	6	11,000	✓
<b>FW6020</b>	60 x 20	6	11,000	✓
<b>FW6025</b>	60 x 25	6	11,000	✓
<b>FW6040</b>	60 x 40	6	11,000	✓
<b>FW6050</b>	60 x 50	6	11,000	✓
<b>FW8015</b>	80 x 15	6	8,000	✓
<b>FW8030</b>	80 x 30	6	8,000	✓
<b>FW8040</b>	80 x 40	6	8,000	✓
<b>FW8050</b>	80 x 50	6	8,000	✓
<b>ORDER REF - M(FW....)-(SHANK)-(GRIT)</b>				

## STRAIGHT ABRASIVE CARTRIDGE ROLLS

Ideal for finishing operations on inside diameters, dead-end holes and lapping operation. Their self-renewing features of wearing through one layer of abrasive to uncover the layer beneath, makes them an excellent tool for blending where high finishes are required.

**Sold in Packs of 100**



GRINDING

STRAIGHT CARTRIDGE ROLLS					
REF	Dia x Length	GRITS	MANDREL	Max.RPM	
MCR1	3 x 19	80 / 120	CRM1	22,000	✓
MCR2	4.5 x 19		CRM2	22,000	✓
MCR3	6 x 19		CRM3	22,000	✓
MCR4	6 x 25		CRM4	22,000	✓
MCR5	9.5 x 25		CRM4	22,000	✓
MCR6	9.5 x 38		CRM5	22,000	✓
MCR7	12 x 25	60 / 120	CRM4	22,000	✓
MCR8	12 x 38		CRM5	22,000	✓
MCR9	19 x 25		CRM6	18,000	✓
MCR10	19 x 38		CRM7	18,000	✓
MCR11	25 x 38		CRM7	10,000	✓
<b>ORDER REF - MCR(No)-(GRIT)</b>					

## TAPERED ABRASIVE CARTRIDGE ROLLS

Useful on channels, fillets and irregular concave contours. When the roll is held at a 45 degree angle to the work, it can reach into angles and corner. When the angle is reduced, greater abrasive surface is presented and faster cutting action results.

**Sold in Packs of 100**

TAPERED CARTRIDGE ROLLS					
REF	Dia.x Length	GRITS	MANDREL	Max.RPM	
MCRT1	9.5 x 25	60 / 120	CRM4	22,000	✓
MCRT2	12 x 25		CRM4	22,000	✓
MCRT3	12 x 38		CRM5	22,000	✓
MCRT4	19 x 25		CRM4	18,000	✓
MCRT5	19 x 38		CRM5	18,000	✓
MCRT6	25 x 38		CRM5	10,000	✓
<b>ORDER REF - MCRT(No)-(GRIT)</b>					

## CARTRIDGE ROLL HOLDERS

To suit cartridge rolls, hardened steel mandrels.

**Sold Individually**



- A) Pilot Diameter
- B) Pilot Length
- C) Shank Diameter
- D) Shank Length

CARTRIDGE ROLL MANDRELS					
REF	PILOT	PILOT	SHANK	SHANK	
	DIAMETER	LENGTH	DIAMETER	LENGTH	
CRM1	2	25	1/8"	25mm	✓
CRM2	2.4	25			✓
CRM3	3.2	12			✓
CRM4	3.2	19			✓
CRM5	3.2	25			✓
CRM6	4.8	19			✓
CRM7	4.8	25			✓
<b>ORDER REF - MD(No)</b>					

## DIAMOND-COATED CLOTH DISCS

The tool interfacing consists of a flexible terylene resilient material, through which it is electroplated with nickel micro-pellets containing diamond abrasives. Diamond is the hardest abrasive available:

- It removes stock fast and retains its speed of cutting throughout its working life
- The material is cool running.
- To obtain maximum lifespan, use with wet lubrication.

NOTE - Only available with self-adhesive backing.



### Sold in Packs of 10

Diamond strips also available please enquire.

DIAMOND GRADES		
Colour	Grit	Micron Size
Green	60/80	250
Black	120	125
Red	200	74
Yellow	400	30~40
White	800	15~30
Blue	1500	6~12

DIAMOND COATED CLOTH DISCS							
Diameter	12mm	20mm	25mm	30mm	50mm	75mm	
Green	✓	✓	✓	✓	✓	✓	
Black	✓	✓	✓	✓	✓	✓	
Red	✓	✓	✓	✓	✓	✓	
Yellow	✓	✓	✓	✓	✓	✓	
White	✓	✓	✓	✓	✓	✓	
Blue	✓	✓	✓	✓	✓	✓	
ORDER REF - SADD(SIZE)-(GRADE)							

GRINDING

## MICRO-MESH DISCS

### Micro-Mesh DISCS

Discs are available in MX, Regular, AO and Diamond, both self-adhesive and Velcro backed. Please contact us for Diamond grade.

We stock the most popular diameters (as below). However, discs can be produced in any diameter from 10" to 3/8".

We can produce with or without extraction holes, an 8+1 set up is most popular but we can also make a bespoke hole pattern. Please contact for more details.

Micro-Mesh REGULAR	Micro-Mesh MX	Micro-Mesh ALUMINUM OXIDE	FEPA OR EURO	MICRON
		300 AO	P180	80
	60 MX		P240	60
	80 MX		P360	45
	100 MX	600 AO		
	120 MX		P400	42
	150 MX	800 AO		
1500 R	180 MX	1500 AO		30
1800 R	240 MX	1800 AO		15
2400 R	320 MX	2400 AO		
3200 R	360 MX	3200 AO		
3600 R	400 MX	3600 AO		8
4000 R	600 MX	4000 AO		5
6000 R	800 MX	6000 AO		4
8000 R	1200 MX	8000 AO		3
12000 R		12000 AO		1



DISCS ON VELCRO OR SELF ADHISIVE BACKING					
TYPE	3"	5"	6"	8"	
AO Kit 7 grades	✓	✓	✓	✓	
REGULAR kit 9 grades	✓	✓	✓	✓	
MX kit 13 grades	✓	✓	✓	✓	
SINGLE DISC ANY GRADE	✓	✓	✓	✓	
ORDER REF - MIC-VELCRO					



## 115MM SURFACE CONDITIONING DISCS

Excellent for surface preparation on Stainless Steel and Aluminium.  
Prepare metal prior to polishing.

- Velcro backed
- To suit the M14 backing pad with raised centre
- The centre hole in the discs centralises the pad and stops it moving in use.



### 115MM DIA VELCRO DISC HOLDER

**Holder with M14 Internal Thread & Raised Centre**



**ORDER REF - BACKINGPAD-115-M14-VELCRO/SCM**

### SURFACE CONDITIONING DISCS

**115mm surface conditioning discs with 20mm c/h - EACH**



**ORDER REF - SCD-115**

### Sold Individually

Velcro-backed discs for surface finishing, turbine blade smoothing, weld blending, paint removal, burr removal. Fibre-backed discs are used when extra aggression is required on the work piece.

GRINDING

## SMALL SURFACE CONDITIONING DISCS

Excellent for surface preparation on Stainless Steel and Aluminium

- Velcro backed (not scrim backed)
- Use with Velcro disc holders of the appropriate size



### GRADES

**Extra Coarse-Black**  
**Coarse-Brown**  
**Medium-Red**  
**Fine-Blue**



### VELCRO SURFACE CONDITIONING DISCS

Diameter (mm)	Pack Quantity	Grade	
20mm	Per 50	All Grades	✓
30mm	Per 50		✓
50mm	Per 20		✓
75mm	Per 20		✓
150mm	Per each		✓
115mm	Per each		✓

**ORDER REF - VELCRO(SIZE)**

## TWIST-N-LOK DISCS

Alternative to self-adhesive discs  
Resin Bond Aluminium Oxide  
The plastic backing gives more rigidity than the quick-change discs offer, keeping them flatter.

**Sold in Packs of 100**



### TWIST-N-LOK DISCS

REF	DIA (mm)	GRITS	MAX. RPM	
TL0025	25	60 80 120 180	30,000	✓
TL0038	38			✓
TL0050	50	36 50	20,000	✓
TL0075	75	60 80 120 180		✓

**ORDER REF - MTL.....**

### TWIST-N-LOK HOLDERS

REF	Size	
SL100	Holder (6mm shank) fits 25/38mm Discs	✓
SL101	Holder (6mm shank) fits 50/75mm Discs	✓

**ORDER REF - MSL.....**

**Roloc fitting - limited availability in Unitized, Aluminium Oxide and Surface Conditioning materials**





**QUICK CHANGE SURFACE CONDITIONING DISCS**

Ideal where an efficient and cost-effective method is required for cleaning, finishing, deburring or surface preparation of a metal, composite or plastic surface. They can be used in conjunction with coated abrasives or as a one-step surface conditioning product.

**Sold in Packs of 100**

**BUFF & BLEND QUICK-CHANGE DISCS**

Fast and effective removal of light oxidation, blending minor surface imperfections and the preparation of surfaces prior to painting and general equipment clean-up.

Made from nylon abrasive type material.

**Sold in Packs of 100**

**38MM & 75MM ALSO AVAILABLE - PLEASE ENQUIRE**



**ALUMINIUM OXIDE QUICK-CHANGE DISCS**

This style of disc is designed to provide long life and quick stock removal on most general purpose grinding applications.

**Sold in Packs of 100**



**QUICK-CHANGE DISC HOLDERS**

To suit all quick-change discs, select the appropriate size. **Sold Individually**



QUICK CHANGE - SURFACE CONDITIONING DISCS					
Pack of 100	DIAMETER				
	19mm	25mm	38mm	50mm	75mm
Coarse					
Medium	✓	✓	✓	✓	✓
Very Fine					
Extra Coarse	X	X	X	✓	X
ORDER REF - QCDRECON					

QUICK CHANGE - BUFF & BLEND DISCS		
Pack of 100	DIAMETER	
	25mm	50mm
HDSR - Medium	✓	✓
Fine or Very Fine	✓	✓
ORDER REF - QCDBUFF		

**GRINDING**

QUICK CHANGE A/O DISCS					
Pack of 100	DIAMETER mm				
GRIT	19mm	25mm	38mm	50mm	75mm
24	✓	✓	✓	✓	✓
36	✓	✓	✓	✓	✓
40	✓	✓	✓	✓	✓
50	✓	✓	✓	✓	✓
60	✓	✓	✓	✓	✓
80	✓	✓	✓	✓	✓
100, 120, 150, 180, 240, 320	✓	✓	✓	✓	✓
Now also available in Ceramic. POA					
ORDER REF - QCD					

UNITIZED QUICK CHANGE DISCS		
Pack of 10	DIAMETER mm	
GRIT	25mm	50mm
2SF SOFT/FINE	✓	✓
6SF MEDIUM	✓	✓
8AC COARSE	✓	✓
ORDER REF - QCDUNIT		

QUICK CHANGE HOLDERS					
For use with all Quick-Change Discs - shafts available in 6mm or 1/4" diameter.					
19mm & 25mm available on 3mm	19mm	25mm	38mm	50mm	75mm
	✓	✓	✓	✓	✓
ORDER REF - QCMANDRELL					

# SELF-ADHESIVE & VELCRO BACKED DISCS



## SELF-ADHESIVE & VELCRO BACKED DISCS

Moleroda offers a range of abrasive cloths with a choice of either Velcro or self-adhesive backing - Sold in Packs of 50

ALUMINIUM OXIDE RINGS (for flexible holders)		
60, 80, 120, 180, 240, 320, 400	20 x 6 CH	✓
	30 x 10 CH	✓
	52 x 25 CH	✓
ORDER REF - SAR		

ALUMINIUM OXIDE DISCS			
Available Grits	Diameter	SELF ADHESIVE	VELCRO
60, 80, 120, 180, 240, 320, 400	10mm	✓	✓
	12mm	✓	✓
	20mm	✓	✓
	25mm	✓	✓
	30mm	✓	✓
	50mm	✓	✓
	75mm	✓	✓
ORDER REF -		SAD	VELCRO

GRINDING

ALUMINIUM OXIDE



### ZIRCONIA (BLUE)

Coolant filled abrasive that gives a sharper cut  
Please contact us for details



SILICON CARBIDE RINGS (for flexible holders)		
60, 80, 100, 120, 150, 180, 240, 320, 400, 500, 600, 800, 1000, 1200, 1500, 2000, 2500, 3000, 5000, 7000	20 x 6 CH	✓
	30 x 10 CH	✓
	52 x 25 CH	✓
ORDER REF - SAR		

SILICON CARBIDE DISCS			
Available Grits	Diameter	SELF ADHESIVE	VELCRO
60, 80, 100, 120, 150, 180, 240, 320, 400, 500, 600, 800, 1000, 1200, 1500, 2000, 2500, 3000, 5000, 7000	10mm	✓	✓
	12mm	✓	✓
	20mm	✓	✓
	25mm	✓	✓
	30mm	✓	✓
	50mm	✓	✓
	75mm	✓	✓
ORDER REF -		SAD	VELCRO



SILICON CARBIDE (WET & DRY)



FOAM BACKED ABRASIVE (VELCRO ONLY)



FOAM BACK ABRASIVE DISCS			
Available Grits	Diameter	Pack Size	
VELCRO			
60, 120, 220, 400, 600	20mm	50 Per Pack	✓
	25mm		✓
	30mm		✓
	50mm		✓
	75mm	10 Per Pack	✓
	100mm		✓
	150mm		✓
ORDER REF - VFB-(DIA)-(GRIT)			

## 52mm SELF ADHESIVE RING HOLDERS

**FLEXIBLE** - Holder for surface work

**RIGID** - Holder for slots and ribs

**Sold Individually**

**Rings can be stuck on both sides**

**Flexible**

1mm thick



**Rigid**

2mm thick



## VELCRO ADHESIVE DISC HOLDERS

Available with or without foam

**Sold Each**

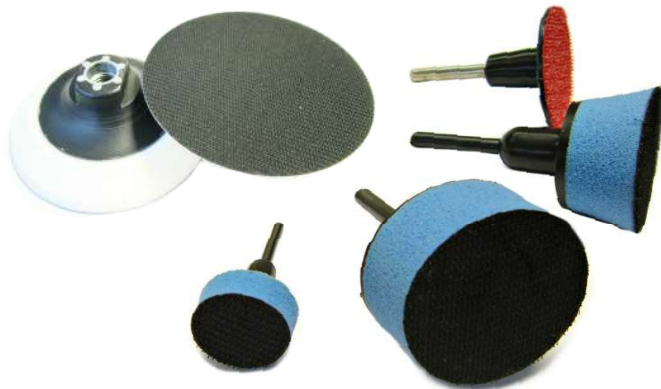

VELCRO DISC HOLDERS			
Diameter	Spindle	Type	
18mm	3mm	Flexible	✓
30mm	3mm		✓
30mm	6mm		✓
25mm	3mm	No Foam	✓
	3mm	Foam Face	✓
50mm	6mm	No Foam	✓
	6mm	Foam Face	✓
	M14	Medium	✓
75mm	M14	No Foam	✓
	6mm	Foam Face	✓
	6mm	Medium	✓

**ORDER REF - VELCROHOLDER**

VELCRO DISC HOLDERS OVER 100MM			
Diameter	Spindle	Type	
100mm	M14	Medium	✓
115mm	M14	With Centre Hole for Surface Conditioning Discs	✓
115mm	M14	Medium	✓
150mm	M14	Medium	✓
200mm	M14	Medium	✓

**ORDER REF - BACKINGPAD**

## SELF ADHESIVE DISC HOLDERS

Flexible rubber/plastic or foam faced

**Sold Individually**



SELF ADHESIVE DISC HOLDERS			
Diameter	Spindle	Flexible Rubber/Plastic	Foam-Faced Rubber
10mm	3mm or 1/8"	✓	✓
12mm	1/8"	✓	✓
20mm	3mm or 1/8"	✓	✓
25mm	3mm or 1/8"	✓	✓
30mm	3mm or 1/8"	✓	✓
50mm	1/4"	✓	✓
75mm	1/4"	✓	✓
	6mm	✓	✓

**ORDER REF - SADH**

SELF ADHESIVE DISC HOLDERS OVER 100MM			
Diameter	Spindle	Flexible Rubber/Plastic	Foam-Faced Rubber
100mm	M14	✓	x
115mm		✓	
150mm		✓	
200mm		✓	

**ORDER REF - BACKINGPAD**

**GRINDING**



RODA is a superior range of polishing and deburring products, for precision finishing, manufactured in the UK. RODA products consistently over-deliver on performance and efficiency.

# RODA POINT



GRINDING

Developed with experienced deburring professionals, specifically constructed to provide high performance deburring suitable for use on all materials. Used in F1, Aerospace, Marine and Medical.

UNITIZED, VORTEX & NORTON WHEELS			
SIZE (mm)	UNITIZED 80G, 120G, 240g	VORTEX	NORTON 3SF
2.35mm & 3mm Shank - Pack of 10			
22 x 3	✓	✓	✓
22 x 6	✓	✓	✓
25 x 3	✓	✓	✓
25 x 6	✓	✓	✓
ORDER REF. - (DIA)X(THICKNESS)UNIT(GRADE)			

UNITIZED, VORTEX & NORTON POINTS			
SIZE (mm)	UNITIZED 80G & 120G	VORTEX	NORTON 3SF
2.35mm & 3mm Shank - Pack of 10			
6 x 12	✓	✓	✓
10 x 12	✓	✓	✓
6mm Shank - Pack of 10			
12 X 25	✓	✓	✓
16 x 25	✓	✓	✓
20 x 10	✓	✓	✓
20 x 25	✓	✓	✓
25 x 25	✓	✓	✓
ORDER REF - UNIT-W-	(SIZE)-(GRADE)	(SIZE)-3M-VORTEX	(SIZE)-3SF

**UNITIZED GRADES**  
**COARSE - Vortex Blue Norton**  
**MEDIUM - RODA Red**  
**FINE - 3sf Grey Norton**

**NORTON UNITIZED**

Softer than our standard unitized points. Ideal for surface improvement. 3SF contains fine silicon carbide grit equivalent to a grade between 180g & 240g. Perfect for fine grinding or work on softer metals.

**VORTEX**

High-performance engineered grain similar to ceramic provides aggressive, fast, stock removal, reduced cycle times and increased part quality. Suitable for hard surfaces, titanium Inconel and other exotic metals. All points can be shaped to bullnose or conical

**Points & Wheels Sold in Packs of 10**

**MOUNTED UNITIZED WHEELS**

Unitized material is made from a baked and compressed nylon abrasive. Excellent on all metals - ferrous and non-ferrous.

**Aluminium** - Good for machine line removal, light and heavy marks and burrs. They leave a good finish with no pick up.

**Stainless Steel** - They clean up light marks and stains in one hit leaving a good, bright finish.



**MOUNTED MX POLISHING POINTS**

MX material is rubber bonded cotton fibre impregnated with aluminium oxide grain. MX points give a finer, shinier finish than conventional abrasive points with an equal grit. They have good results on more difficult steels. They do not clog and offer a long working life.



Sold in Packs of 10

**SPEEDS & FEEDS**



Diameter	Deburring max RPM at 15 m/s
6	40,000
8	36,000
10	28,000
12	25,000
14	21,000
16	18,000

MX MOUNTED POINTS			
SHAPE	SIZE (mm)	80g/120g/180g	320g
		pack of 10	pack of 10
1/8" or 3mm Shank			
W145	3 x 10	✓	✓
W154	5 x 13	✓	✓
W163	6 x 12	✓	✓
W176	10 x 12	✓	✓
W177	10 x 20	✓	✓
When ordering, specify grit required (80, 120, 180, or 320) and shank diameter			
MXCW - SHAPE, SHANK, GRIT, MATERIAL			

**GRINDING**

**(HARD) MC-FLEX**

Similar to GFX type, except with a harder bonding for longer life. Best for edge work, less bounce & smoother finish than pink points, burrs & diamond points

**(SOFT) GFX - Most Popular**

GFX is latex-bonded cotton fibre, recommended for blending and polishing as well as slight stock removal. Excellent for runners, aluminium and stainless steel. Flexible bond.

Materials	3SF	GFX	RED	BLUE VORTEX	MC FLEX
Soft	●	●			
Aluminium	●	●	●		
Mild Steel		●	●	●	
Stainless Steel			●	●	●
Heat Treated				●	●
Exotics				●	●

RODA MX POINTS			
PACK OF 10			
SHAPE	SIZE(MM)	SPINDLE	MATERIAL
MXB612	6X12	3MM	GFX
MXB1012	10X12	3MM	GFX
MXB1212	12X12	3MM	GFX
MXC612	6X12	3MM	GFX
MXC1012	10X12	3MM	GFX
MXC1212	12X12	3MM	GFX
MXT	2.5/12	3MM	GFX
MXT	2.5/12	2.35MM	GFX
ORDER REF. - MXB, MXC, MXT			



**RODA MX POINTS**



We are excited to launch our very own brand new premium range of MX polishing points. This range will hold your material perfectly and offer a great finish on any metal. Unlike the rest of our RODA Point range – this new variation comes only in 125GFX.

Shapes available in:  
**MXB: BOB**  
**MXC: CONE**  
**MXT: TAPER**

MOLERODA  
RECOMMENDS



RODA is a superior range of polishing and deburring products, for precision finishing, manufactured in the UK. RODA products consistently over-deliver on performance and efficiency.

# RODA NYWHEEL



GRINDING

**RODA NyWheel:**

The only Surface Finishing and Deburring tool you need to complete your part!

Developed alongside trusted engineers to specifically formulate high grade nylon products with finishing properties. Abrasive nylon offers abrasive cleaning and satin finishing on a full range of materials. They quickly and efficiently remove and blend machine lines, work well on threads and down holes. The material gives a consistent finish for a smart, clean result.

RODA NyWheels				
Material	22mm	25mm	30mm	40mm
2.35mm Shank x 2 lap (3 lap also available)				
ALL OTHER GRADES	✓	✓	X	X
F1000 - GOLD	✓	✓	X	X
ORDER REF - VSM-(DIA)X(LAPS)				
Material	22mm	25mm	30mm	40mm
3mm Shank x 3 Lap (2 and 1 lap also available)				
F0 - WHITE	✓	✓	✓	✓
F1000 - GOLD	✓	✓	✓	✓
F600 - GREY	✓	✓	✓	✓
M400 - GREEN	✓	✓	✓	✓
M320 - MA	✓	✓	✓	✓
C180 - CA	✓	✓	✓	✓
C120 - HDMA	✓	✓	✓	✓
C110 - BLACK	✓	✓	✓	✓
C100 - BROWN	✓	✓	✓	✓
C80 - HDVCA	✓	✓	✓	✓
ORDER REF - (DIA)X(LAPS)L-3				

Material	Colour	Desc	Grade	Operation	Finish	PLASTICS	PRECIOUS METALS	BRASS	ALUMINIUM	MILD STEEL	STAINLESS STEEL	EXOTICS
F0	White	White	0	Deflash Clean Polish	A non abrasive material offering a clean finish	●						
F1000	Gold	Gold	1000	Clean Polish	This material offers a bright finish on metals	●	●	●	●			
F600	Grey	UFS	600	Deburr Finish	A silicon carbide material offering a machine brush finish		●	●	●		●	
M400	Green	Green	400	Deburr Finish	A medium deburring and finishing material offering a machine brush finish		●	●	●		●	●
M320	Red	MA	320	Deburr Finish	A medium material offering removal of slight machine lines, whilst leaving a satin finish			●	●		●	●
C180	Red	CA	180	Deburr Finish	A coarse material offering removal of slight machine lines, whilst leaving a satin finish			●	●		●	●
C120	Red	HDMA	120	Deburr Finish	A coarse material offering removal of heavier machine lines, whilst leaving a brush finish				●		●	●
C110	Black	BLACK	110	Deburr Finish	A silicon carbide material with great cutting properties to remove deep machine lines and offer a bright finish				●	●	●	●
C100	Brown	BROWN	100	Deburr Finish	A superior coarse material offering graining ability as well as deburring, offering a a bright brush finish on all metals				●	●	●	●
C80	Red	HDVCA	80	Deburr	An extremely coarse grade for deburring / cleaning					●	●	●

**GRINDING**

**SPEEDS & FEEDS**



Diameter	Deburring max RPM at 30 m/s	Surface Prep max RPM at 25 m/s
<b>22</b>	26,000	22,000
<b>25</b>	24,000	20,000
<b>30</b>	20,000	16,000
<b>40</b>	16,000	12,000



# MOUNTED ABRASIVE NYLON



## SMALL MOUNTED BUFFING BALLS

Both felt and abrasive nylon buffing balls on 2.35mm and 3mm spindles. With twice as much material as standard felt and nylon wheels they are longer lasting.



Sold in Packs of 10



SMALL MTD BUFFING BALLS					
Per 10					
Material	Shank	22mm	25mm	30mm	40mm
All Abrasive Nylon (All Grades)	2.35mm	✓	✓	x	x
ORDER REF - VSM-(DIA)X6LX3/32-(MATERIAL)					
All Abrasive Nylon (All Grades)	3mm	x	✓	✓	✓
ORDER REF - (DIA)X6LAP-3MM(MATERIAL)					

GRINDING

### Abrasive Nylon Grades:

**BLACK** (Silicone Carbide), **HDVCA** (Heavy Duty Very Coarse), **HDMA** (Heavy Duty Medium), **CA** (Coarse), **MA** (Medium), **FA** (Fine), **GREEN** (Non-Abrasive), **UFS** (Ultra Fine), **WHITE** (Finest)



## LARGE MOUNTED BUFFING BALLS

The ball shape gives the top washer more coverage allowing you to use the top of the ball as well as the sides without scratching. Twice as much material for a longer lasting product.

- Large diameters on a 6mm re-usable shank.
- The screw mandrel allows laps to be replaced.
- The reverse threaded mandrel won't loosen during use.

Sold Individually

On a MM506 Reusable Mandrel

### LARGE BUFFING BALL REFILLS

Replacement laps in felt or abrasive nylon make this product extremely economical.

Sold in 20 Laps



LARGE MTD BUFFING BALLS				
Sold Each				
Material	Shank	50mm	75mm	100mm
All Abrasive Nylon Grades	6mm	✓	✓	✓
ORDER REF - BUFFINGBALL-(DIA)-(MATERIAL)				
LARGE BUFFING BALL REFILLS				
Per 20 Laps				
Material	50mm	75mm	100mm	
All Abrasive Nylon Grades	✓	✓	✓	
ORDER REF - BUFFINGBALLREFILL-(DIA)-(MATERIAL)				



## GRIT IMPREGNATED NYLON

- Particularly good for threads.
- Much harder than radial discs.
- Work well for reaching into detail.
- On a 2.35mm shank.

Sold in Packs of 10



GRIT IMPREGNATED NYLON WHEELS			
22mm x 2.35mm Shank			ORDER REF
Medium, Al.Oxide	Softer	✓	VSMAN22AOM-3/32
Medium, Sil.Carbide	More Aggressive	✓	VSMAN22SIC-3/32



ABRASIVE NYLON WHEELS WITH SHANK (LOOSE TYPE)							
ORDER REF	Diameter	Width	Brush	Shank	Grit	Max.RPM	
			Length	Dia.	240 Fine		
GSM-30	75mm	25mm	25mm	6mm	940-666	5000	✓



ABRASIVE NYLON WHEELS WITH SHANK (FIRM TYPE)								
ORDER REF	Diameter	Width	Brush	Shank	Grits		Max. RPM	
			Length	Dia.	120 Medium	240 Fine		
GSW-40	100mm	6mm	25mm	6mm	941-714	~	5000	✓
		10mm	25mm	6mm	~	941-726	5000	✓

GRINDING

## MOUNTED FINISHING WHEELS

Abrasive nylon flap wheels on 6mm

Sold Individually



MOUNTED FINISHING WHEELS				
Ref	Dia x Width	Grades	Max rpm	
	(mm)	Available		
NF0030	30 x 20	VFA FA	16,000	✓
NF0050	50 x 25	VFA FA CA	12,000	✓
NF0063	63 x 32	VFA FA	8,000	✓
NF0075	75 x 45	VFA FA MA-SUPER CUT	8,000	✓
NF0100	100 x 45	VFA FA MA	6,500	✓

ORDER REF - NF(REF No)

## MOUNTED INTERLEAVED FINISHING WHEELS

Abrasive nylon flap wheels interleaved with abrasive cloth on 6mm

Sold Individually



MTD INTERLEAVED FINISHING WHEELS				
Ref	Dia x Width	Grits	Max rpm	
	(mm)	Available		
IF0030	30 x 20	100 150 240	16,000	✓
IF0050	50 x 25	100 150 240	12,000	✓
IF0063	63 x 32	100 150 240	8,000	✓
IF0075	75 x 45	60 100 150 240	8,000	✓
IF0100	100 x 45	60 100 150 240	6,500	✓

ORDER REF - IF(REF No)

# RUBBER POINTS & WHEELS



## MOUNTED RUBBER POINTS

Especially good on non-ferrous metals including aluminium, silver and gold.

- Rubber points are easily shaped
- Clean and simple to use

**Sold in Packs of 10**



We can also supply conical and bullnose rubber points on 3mm and 2.35mm spindles. (Replace W with C or B for the order ref.)

MTD RUBBER POINTS				
SHAPE W - C - B	SIZE (mm)	Max. Safe Operating Speed	80/120/180	80/120/180
			3mm SHANK	2.35mm SHANK
W145	3 x 10	55,000 rpm	✓	X
W154	5 x 13	55,000 rpm	✓	✓
W163	6 x 13	55,000 rpm	✓	✓
W176	10 x 13	45,000 rpm	✓	X
W185	13 x 13	34,000 rpm	✓	X
Specify grit required: 80 (Red), 120 (Blue), 180 (Green)				
ORDER NO			RP-W...	RP-W...-2.35

RUBBER POINT SETS		
KIT 20	10 PIECE SET ON 3MM	✓
KIT 58	10 PIECE SET ON 2.35MM	✓
KIT 53	10 PIECE SET ON 2.35MM (CONICAL)	✓
ORDER NO - POLKIT-(NUMBER)		

GRINDING

## ELASTIC POLISHING POINTS

Elastic polishing points are suited to most materials, hard and soft. Leaving a matt finish, they give excellent cut. Recommended speed 5,000 - 10,000 RPM.

**Sold Individually**



ELASTIC POLISHING POINTS ON 2.35MM				
Tip	Head Dimensions	Grit Size		ORDER REF
Soft Bond	4.5 x 12	Coarse 80g	✓	JOKE-O542901
	4.5 x 12	Medium 150g	✓	JOKE-O542902
	4.5 x 12	Fine 240g	✓	JOKE-O542903
Tip	Head Dimensions	Grit Size		ORDER REF
Hard Bond	3.3 x 7.5	Coarse 80g	✓	JOKE-O542907
	3.3 x 7.5	Medium 150g	✓	JOKE-O542908
	3.3 x 7.5	Fine 240g	✓	JOKE-O542909

## EDENTA TOP STAR WHEELS

14.5mm x 2mm on 2.35mm spindle. Silicon Carbide.

**Brown** is for scratch removal **Green** for polishing. Particularly popular for jewellery finishing. Very effective on gold and silver, also useful for aluminium, brass etc

**Sold Individually**



EDENTA TOPSTAR	
<b>Brown or Green</b>	✓
ORDER NO - EDTOPSTAR	

## EDENTA CERAGLOSS WHEELS

25mm dia. on 2.35mm spindle  
**Diamond impregnated** wheels

**Blue** is a medium grade for removing scratches.  
**Yellow** is a fine grit for a high gloss finish.

Superior finishing for metals such as Titanium, Platinum and Carbide (including Gravers). Commonly used by stone setters for polishing.

**Sold Individually**



EDENTA CERAGLOSS	
<b>Blue or Yellow</b>	✓
ORDER NO - EDCERAGLOSS	

**CRATEX RUBBERISED ABRASIVES**

For light deburring, smoothing, cleaning and polishing

**Basic Applications**

- LIGHT DEBURRING and smoothing to relieve stress concentrations and to remove visible and microscopic burrs without impacting surrounding areas.
- CLEANING and polishing to remove undesirable surface deposits.
- SMOOTHING and polishing to improve wearing qualities and to reduce the dangers of progressive fracture and fatigue failure.
- POLISHING and smoothing to improve performance, appearance, cleanliness and to lessen the dangers of surface contamination.

**CRATEX WHEEL MANDREL NO.1342**

Cratex Wheel Mandrel No.1342 has 1/4" shank and is designed for 1/4" centre hole wheels up to 3" diameter by 1/2" thick or less. MSS is 20,000 rpm and best results are usually obtained at 30% to 80% of MSS. Use light work pressure.

**Sold Individually**

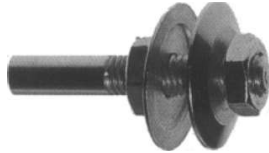

**1342 Mandrel**  
✓  
**ORDER REF - MM1342C**

**CRATEX KITS**

A great selection of grits and shapes to get started.

**Sold Per Kit**



**CRATEX KIT 778**  
✓  
**ORDER REF - CRATEX-778**



**CRATEX KIT 777**  
✓  
**ORDER REF - CRATEX-777**

**GRIT TEXTURES**

Each Cratex size and shape is made in four standard grit textures or compositions which differ in accordance with the mesh size of the abrasive grain used.

- [C] Coarse (Green)
- [M] Medium (Dark Brown)
- [F] Fine (Reddish Brown)
- [XF] Extra Fine (Grey-Green)

**CONES**

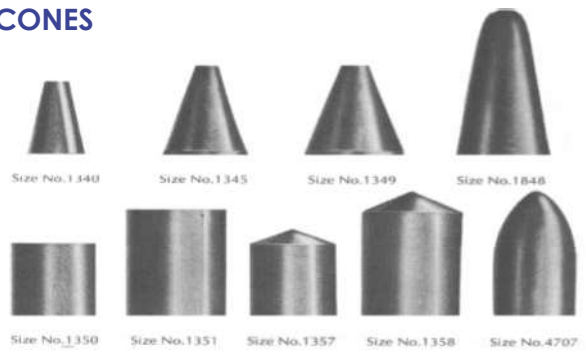

**POINTS**

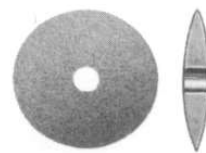

Size No. 2

**SMALL WHEELS STRAIGHT EDGE**

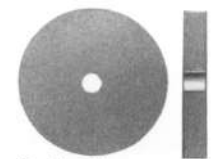

Size No. 74

**SMALL WHEELS TAPERED EDGE**

**BLOCKS & STICKS**



Please ask for available sizes.

**GRINDING**





# SUNBURST®

## WHAT IS SUNBURST?

Sunburst is a unique range of thermoplastic-bonded abrasives for deburring, finishing, cleaning and polishing metals, plastics, acrylics, ceramics and woods.

- Available individually & in handy assortments in multiple grits, shapes and sizes. Colour coded for easy identification.
- Use with precision flex- shaft tools and micro-motors, bench & variable speed angle grinders. Preferred choice for CNC machines and robotics where conformability and durability are key.

GRINDING

## ABRASIVE-FILLED THROUGHOUT



## LIMITLESS APPLICATIONS

**JEWELLERY** - Precision range is ideal for finishing, smoothing and high-lustre polishing of all precious, semi-precious and non-precious metals. No messy compounds required! Even the pumice discs will not scratch stones.

**WOODWORKING** - Superior to sandpaper, flap wheels and other types of sanders, brushes and abrasive wheels for woodcarving and woodworking.

**INDUSTRIAL** - Instantly removes rust, corrosion, paint and more from metal surfaces. Especially effective on aluminium and stainless steel for MRO, metal fabrications and job shops serving Aerospace, Auto, Marine and general industry.

**SUNBURST** radial bristle discs and brushes are the perfect alternative to wire and nylon. Experience improved performance without threat of injury.

- **SAFER** - Danger from high-velocity needle-like flying wire is eliminated.
- **FLEXIBLE** - Will not scratch or gouge the underlying surface.
- **BETTER** - Works faster and more efficiently than wire brushes. Easily achieves a constant, quality finish with light pressure.

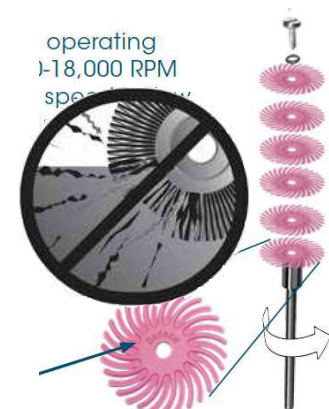

**STACK WITH LOGO  
FACING UPWARDS**



**COLOUR CODE**

 <b>Brown</b>	<b>Ultra-Coarse</b> 36 Grit (A/O)	 <b>Green</b>	<b>Extra-Coarse</b> 50 Grit (A/O)	 <b>Yellow</b>	<b>Coarse</b> 80 Grit (A/O)
 <b>White</b>	<b>Medium</b> 120 Grit (A/O)	 <b>Red</b>	<b>Standard</b> 220 Grit (A/O)	 <b>Blue</b>	<b>Fine</b> 400 Grit (A/O)
 <b>Pink</b>	<b>Fine</b> 600 Grit (Pumice)	 <b>Peach</b>	<b>Extra-Fine</b> 6 Micron (A/O)	 <b>Light Green</b>	<b>Ultra-Fine</b> 1 Micron (A/O)

A/O = Aluminum Oxide

**GRINDING**

**SUNBURST FEATURES**

**CONFORMABILITY** - Flexible bristles conform to contours, cracks and corners while working equally well on flat surfaces.

**LONG-LASTING** - Uniformly blended bristles guarantee extended wear life and a consistent, uniform finish.

**COOL RUNNING** - Generates minimal heat reducing potential damage or distortion to the work surface.

**OPERATING SPEEDS** - Recommended operating speeds for most applications is 3,000 - 18,000 RPM (5,000 for wood working). Lower speeds allow a softer touch, greater flexibility and more subtle results. Higher speeds provide more aggressive material removal. Using the tip of the bristles with light pressure maximizes disc life.

**MODULAR** - Use a single disc for tight areas like slots and grooves or stack them for larger surface areas.



**Bristle Disc Guide**

<p><b>TC</b> - Curved, thinner bristles for greater conformability than <b>TA</b> and <b>TS</b>.</p> <p>Single Directional</p>	<p><b>TA</b> - Angled, thicker bristles for greater aggressiveness but less conformability than <b>TC</b>.</p> <p>Single Directional</p>	<p><b>TS</b> - Straight, thick bristles for greater aggressiveness but less conformability than <b>TA</b>.</p> <p>Dual Directional</p>
--	--	--

DELUXE ASSORTMENT

DELUXE ASSORTMENT

This complete introductory set includes - 1/2" Snap-On, 5/8" & 7/8" Discs, 2mm & 3mm.

Polishing Pins and Points in all grit textures on a 2.35mm shank and 4 off 2.35 mandrels to suit the assortment.

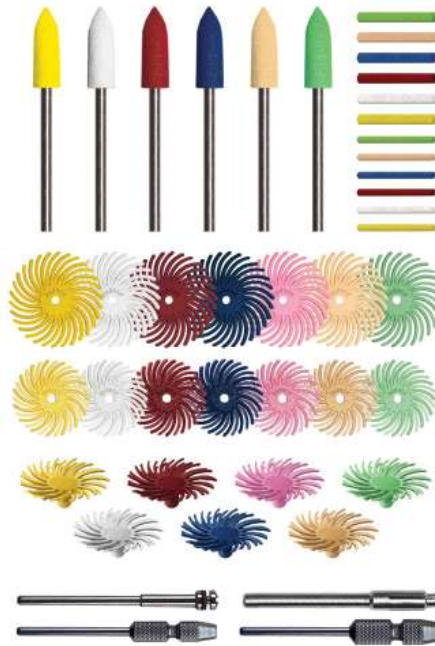

116 PIECE DELUXE ASSORTMENT	
1209	
1209	✓
REF - DED-DELUXEASSORTMENT	

GRINDING

1/2" TC SNAP-ON

1/2" TC SNAP-ON

1/2" TC Snap-On Assortment - 6 of each in all 7 grit textures plus 1 off 5431 (2.35mm)mandrel.

2.35mm mandrels sold separately, discs available individually.



1/2" TC SNAP-ON	
1350	
Assortment	✓
Individually	✓
Mandrel 5431 - 2.35mm	✓
REF - DED-1/2"-SNAPON	

5/8" TC RADIAL DISCS

5/8" TC RADIAL DISCS

5/8" TC Assortment - 12 of each in all 7 grit textures plus 1 off 5425 (2.35mm) mandrel and 1 off 0261 (1/8) mandrel.

3mm mandrels sold separately, discs available individually.



5/8" TC RADIAL DISCS	
1220	
Assortment	✓
Individually	✓
Mandrel MM503 - 2.35mm	✓
Mandrel MM503 - 3mm	✓
REF - DED-5/8-TCRADIAL	

**7/8" TC RADIAL DISCS**

**7/8" TC RADIAL DISCS**

7/8" TC Assortment - 12 of each in all 7 grit textures plus 1 off 5425 (2.35mm) mandrel and 1 off 0261 (1/8) mandrel.

3mm mandrels sold separately, discs available individually.



7/8" TC RADIAL DISCS	
1240	
Assortment	✓
Individually	✓
Mandrel MM503 - 2.35mm	✓
Mandrel MM503 - 3mm	✓
REF - DED-7/8-TCRADIAL	

**GRINDING**

**7/8" TC 4-PLY**

**7/8" TC 4-PLY**

7/8" TC 4-Ply Assortment - 1 of each in all 7 grit textures 3/32" (2.35mm) shanks.

Grades available in individual 4 ply units - on a 2.35 only.



7/8" TC 4-PLY	
1260	
Assortment - 2.35 ONLY	✓
Each 4 Ply Unit - 2.35 spindle ONLY	✓
REF - DED-7/8-TCRADIAL-4PLY	

**7/8" TC DUAL DISCS**

**7/8" TC DUAL DISCS**

7/8" TC Dual Disc Assortment - 6 of each in all 7 grit textures plus 1 off 5425 (2.35) mandrel.

3mm mandrels sold separately, discs available individually.

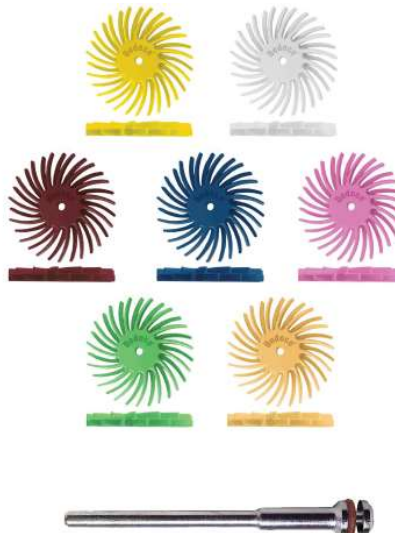

7/8" TC DUAL DISCS	
1920	
Assortment	✓
Individually	✓
Mandrel MM503 - 2.35mm	✓
Mandrel MM503 - 3mm	✓
REF - DED-7/8-TCRADIAL-DUAL	



7/8" TC KNIFE-EDGE

7/8" TC KNIFE-EDGE

7/8" TC Knife-Edge Assortment - 6 of each in all 7 grit textures plus 1 off 5425 (2.35mm) mandrel.

3mm mandrels sold separately, discs available individually.

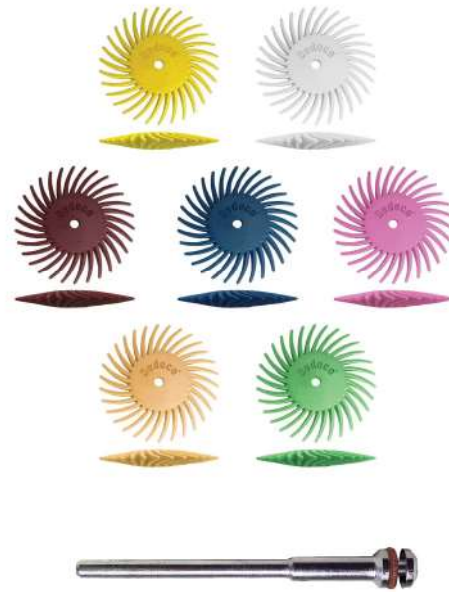

7/8" TC KNIFE-EDGE	
1940	
Assortment	✓
Individually	✓
Mandrel MM503 - 2.35mm	✓
Mandrel MM503 - 3mm	✓
REF - DED-7/8"-TCKNIFE-EDGE	

GRINDING

1" TC RADIAL DISCS

1" TC RADIAL DISCS

1" TC Assortment - 8 of each in all 6 grit textures plus two 1363 (1/8) mandrels.

2.35mm & 3mm mandrels sold separately, discs available individually.



1" TC RADIAL DISCS	
1270	
Assortment	✓
Individually	✓
Mandrel MM503 - 2.35mm	✓
Mandrel MM503 - 3mm	✓
REF - DED-1"-TCRADIA	

ALL-IN-ONE KIT

ALL-IN-ONE

83-piece All-In-One Assortment This popular set includes 4 each 5/8", 7/8" & 1" in all grit textures plus 0261 (1/8), 1363 (1/8) & 5425 (2.35) mandrels.

2.35mm & 3mm mandrels sold separately, discs available individually.



ALL-IN-ONE	
1210	
Assortment	✓
Mandrel MM503 - 2.35mm	✓
Mandrel MM503 - 3mm	✓
REF - DED-SET-1210	



**3" TC RADIAL DISC**

**3" TC RADIAL DISC**  
3" TC Radial Discs

Mandrels sold separately,  
discs available individually.



3" TC RADIAL DISC	
Individually	✓
REF - DED-3"-TCRADIAL	

**GRINDING**

**3" TC RADIAL DISC 3 PLY**

**3" TC RADIAL DISC 3 PLY**  
3" TC Radial Discs 3 Ply

Mandrels sold separately,  
discs available individually.

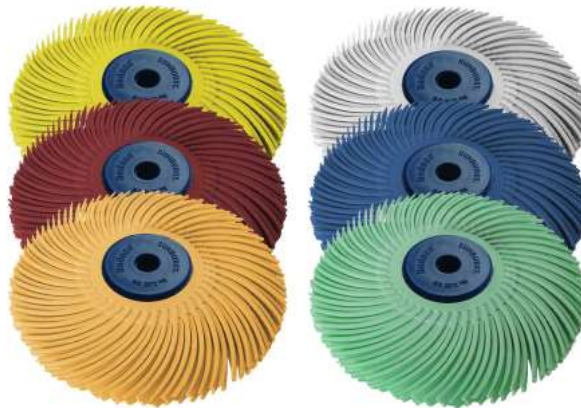

3" TC RADIAL DISC 3 PLY	
1330	
Assortment of 6	✓
Individually	✓
REF - DED-3"-TCRADIAL-ASSORT	

**3" TC RADIAL DISC 6 PLY**

**3" TC RADIAL DISC 6 PLY**  
3" TC Radial Discs 6 Ply

Mandrels sold separately,  
discs available individually.

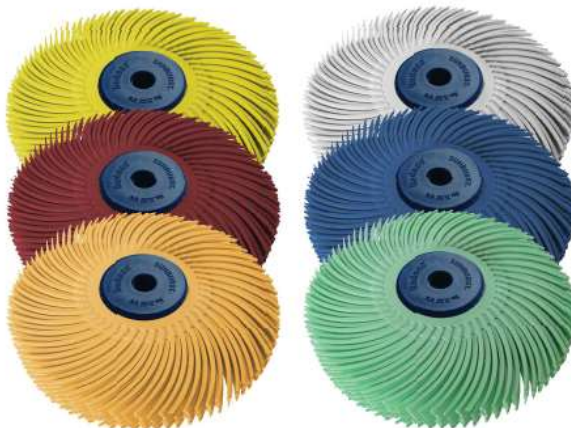

3" TC RADIAL DISC 6 PLY	
1340	
Assortment of 6	✓
Individually	✓
REF - DED-3"-TCRADIAL-6 PLY	

3" TA RADIAL DISCS

3" TA RADIAL DISCS

3" TA Radial Discs. For use on a bench grinder. Available in 4 grades.

Mandrels sold separately, discs available individually.

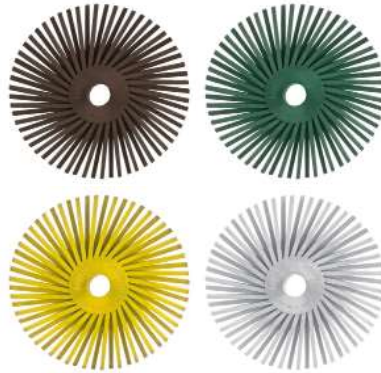

3" TA RADIAL DISCS	
Individually	✓
REF - DED-3"-TARADIAL	

GRINDING

E-Z LOC BRUSHES

E-Z LOC BRUSHES

E-Z Loc Brushes. Available in 1", 2" & 3" in 4 grit textures.

Please contact us if you can't see the size or grade you want.

Mandrels sold separately, brushes available individually.



E-Z LOC BRUSHES	
2" 36g Brown	✓
3" 50g Green	✓
3" 80g Yellow	✓
1" 120g White	✓
REF - DED- (SIZE) E-ZLOCBRUSH	

E-Z LOC MANDRELS	
1" (25mm)	✓
2" (50mm)	✓
3" (75mm)	✓
REF - ROLOC-25/50/75	

3" TA E-Z LOC DISCS

3" TA E-Z LOC DISCS

3" TA E-Z Loc Discs. Available in 4 grit textures.

Mandrels sold separately, discs available individually.



3" TA E-Z LOC DISCS	
Mandrel 3" (Roloc)	✓
REF - DED-3"E-ZLOCDISCS	

**6" TC RADIAL DISCS**

**6" TC RADIAL DISCS**

6" TC Radial Discs. For use on a bench grinder. Available in 6 grades.

Hubs sold separately, discs available individually.

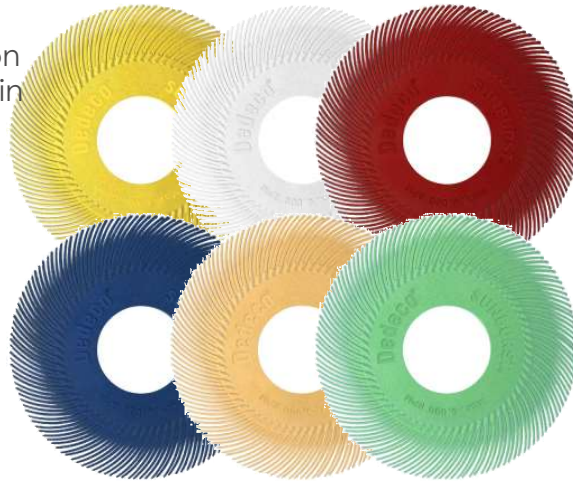

6" TC RADIAL DISCS	
Taper	✓
Flange & Adapter	✓
REF - DED-3"-TARADIAL	

**GRINDING**

**6" X 1/2" TA RADIAL DISCS**

**6" X 1/2" TA RADIAL DISCS**

6" X 1/2" TA Radial Discs. For use on a bench grinder. Available in 3 grades.

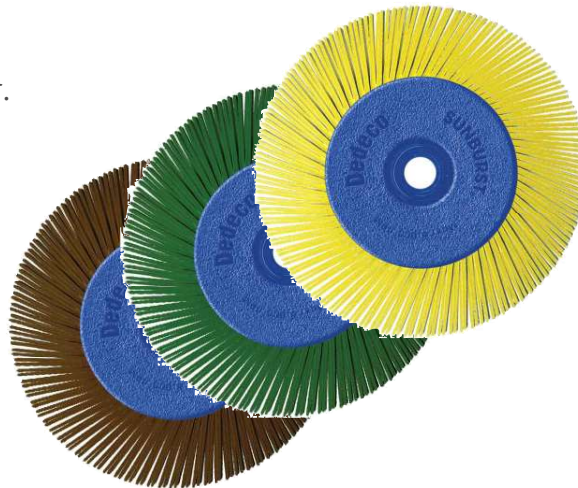

6" X 1/2" TA RADIAL DISCS	
1890 36g - Brown	✓
1891 50g - Green	✓
1892 80g - Yellow	✓
REF - DED-6"X1/2TARADIAL	

**8" X 1" TS RADIAL DISCS**

**8" X 1" TS RADIAL DISCS**

8" X 1" TS Radial Discs. For use on a bench grinder. Available in 3 grades.



8" X 1" TS RADIAL DISCS	
1904 50g - Green	✓
1905 80g - Yellow	✓
1906 120g - White	✓
REF - 8"x1"	

**ALSO AVAILABLE**  
10X1" TS Radial Discs or individual loose leaves. Please contact us for details.



# 3M RADIAL DISCS



## 3M RADIAL DISCS

3M radial discs are becoming a very popular tool across all industries. Suitable for materials from soft plastics to stainless steel.

- these flexible discs are cool running
- non-loading
- they create a controllable uniform finish
- most importantly they are clean to use
- particularly good for deburring threads
- can be used in CNC machines for automated deburring
- used without compound



Always use a minimum of 3 leaves and a maximum of 6 leaves per mandrel

Simply mount the laps onto the appropriate mandrel facing the correct direction as shown in this image with a minimum of 3 leaves.

### MM503 SCREW TOP MANDREL

For 19mm & 25mm radial discs on either 3mm or 2.35mm

### MM506

#### Mandrel on 6mm

For 50mm & 75mm discs, suitable for air tools, drills, flexible shafts that take 6mm shanks (**with reverse thread**)

**Plastic screw centres** fit 50 & 75mm discs for use with bench polishers with a taper.



**80g** Yellow    **220g** Red    **400g** Blue    **Pumice** Pink    **6 micron** Orange    **1 micron** L.Green

### 19mm Discs



### 25mm Discs



**Brown 36g**    **Green 50g**    **Yellow 80g**    **White 120g**    **Red 220g**    **Blue 400g**

3M RADIAL DISCS				
ORDER REF	Size	Unit of Sale	Mount	
<b>HABRAS-19MM</b>	19mm	Individual Leaves	503-3mm or 2.35mm	✓
<b>HABRAS-25MM</b>	25mm		304D - 3mm	✓
<b>HABRAS-50MM</b>	50mm		Plastic Centre or	✓
<b>HABRAS-75MM</b>	75mm		506 Mandrel	✓

MANDRELS		
ORDER REF	Type	
<b>MM503</b>	503 Mandrel - 3/32" or 3mm	✓
<b>MM304D</b>	304 Mandrel - 3mm or 1/8"	✓
<b>HABRASBLACKSCREWCENTRE</b>	Plastic Screw Centre	✓
<b>MM506</b>	Mandrel 506 (6mm shank)	✓

GRINDING



## RADIAL WHEELS

Radial wheels are becoming a very popular tool across all industries. Suitable for materials from soft plastics to stainless steel. 6"/150mm (8-lap unit) radial brushes are ideal for bench grinders with an adjustable centre bore.

- These flexible discs are cool running
- Non-loading
- They create a controllable uniform finish
- Most importantly they are clean to use
- Particularly good for deburring threads
- Can be used in CNC machines for automated deburring
- Used without compound



We've also developed a system for wider 150mm radial brushes up to 50mm wide (to fit an M14 thread), useful for:

- Large panels
- Textured surfaces



We can also supply a taper bore centre to adapt these wheels for taper spindles

GRINDING

RADIAL DISCS					
ORDER REF	Size	Unit of Sale	Mount	Grades	
<b>HABRAS-150MM</b>	150mm	8 lap unit	Included	80, 120, 220, 400, Pumice, 6 Micron, 1 Micron	✓
<b>BK - 1011</b>	150	Individual Leaf	Taper Bore	80, 120, 220, 400, 600, 1000	✓
RADIAL TAPER BORE CENTRE					
<b>BK-1502-TB</b>	For 6" Wheels	Each	~	~	✓



## EXPANDA WHEELS

The expanda wheel is a soft contact wheel which, after mounting onto a tapered screw spindle, expands when the machine is switched on, gripping the abrasive coated or abrasive nylon bands. Can be fitted left or right hand – giving the benefits of finishing at a low cost – excellent results whether using it on contoured or flat surfaces. Offers great flexibility for the polisher and engineer.

**Sold Individually**

### ABRASIVE BELTS FOR EXPANDA WHEELS

Sizes to suit expanda wheel options. Prices based on Aluminium Oxide belts.

**Sold in Packs of 10**

Note: The small expanda wheel 90 x 50mm can be used on portable machines, when operating with no load run at less than 6,000 rpm

**A quick and easy way of turning a polishing lathe into a finisher**

EXPANDA WHEELS		
Dia x Width (mm)	Max.RPM	
90 x 50mm	6,000	✓
150 x 38mm	4,500	✓
ORDER REF - EXPANDERWHEEL-(SIZE)		

ABRASIVE BELTS FOR EXPANDA WHEELS	
Length x Width (mm)	Pack of 10
289 x 50mm	✓
475 x 38mm	✓
ORDER REF - AB(LENGTH X WIDTH)	

GRINDING

## SPECIALIST FINISHING BELTS & DRUMS

- For stainless steels, non-ferrous materials, to lacquer polishing.
- From 80 grit down to 6 micron finish.
- We stock all sizes and types of belts.
- From belts for the Dynaflex and Belton machines, pad sanders to blow up tyres this is the most complete finishing range on offer.
- Can be used wet or dry.
- **Superfinishing Pads SG** start where conventional abrasives reach their limit.

**Coated Abrasive Bands – grits available:**  
**60 80 100 120 150 180 240 320 400**

**Also Available**

- **Trizact**
- **Micro-Mesh**
- **Abrasive Nylon Bands in grades - Coarse (Brown) - Medium (Maroon) - Fine (Blue)**

## PNEUMATIC DRUM (BLOW UP TYRE)

The Formula 1 Tyre for the first place finish. Suitable for a variety of belts – depending on air pressure, one can adjust the finish from hard to soft

- Used with abrasive belts
- 90 x 100 x 19mm keyway
- Takes 100 x 289mm Belts



## Micro-Mesh BELTS

Any length of belt can be produced up to a maximum of 12" wide in any of the Micro-Mesh materials.

**Please contact us with your specific requirements**

PNEUMATIC DRUM	
Dimensions	
90 X 100 X 19mm	✓
ORDER REF - BLOWUPTYRE90X100	

ARBOR	
Dimensions	
FG M14 (19 X 100mm)	✓
ORDER REF- BLOWUPTYRE-ARBOR	

## SCRATCH-BRUSHING FINISHING WHEELS

Crimped Brass wire – a non tufted type. Constructed to provide an even spread of wire, giving an even surface finish. Wooden-centre to fit parallel shafts or tapered spindles.

**Sold Individually**



BRASS VERTEX WHEELS						
Diameter (mm)	Width (mm)	Rows	Hub Dia. (mm)	Wire	Wire	
				Thickness	Type	
100	16	3	40	0.06 mm	Fine	✓
100	16	3	40	0.10 mm	Medium	✓
100	25	5	40	0.06 mm	Fine	✓
100	25	5	40	0.10 mm	Medium	✓
120	16	3	50	0.06 mm	Fine	✓
120	16	3	50	0.10 mm	Medium	✓
120	25	5	40	0.06 mm	Fine	✓
120	25	5	40	0.10 mm	Medium	✓

**ORDER REF - WWBRASS**

Nickel Silver also available.

GRINDING

## PENNY WHEELS

49mm metal or plastic centred penny wheels.

**Sold in Packs of 10**



PENNY WHEELS		
Ref.	Hardness	
BW-PW-Brass	Medium	✓

**ORDER REF - BW-PW(MATERIAL)**

## WIRE WHEELS

Many other sizes and types of wire wheels and brushes are available.

**Sold Individually**

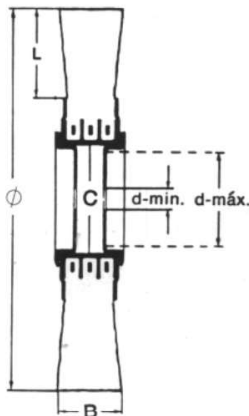

WIRE WHEELS										
Dimensions (mm)					Max.RPM	Type	STEEL			STAINLESS
B	C	L	d/min	d/max			0.20 STD	0.30 STD	0.50 STD	0.30 INOX
<b>4" Diameter (100mm)</b>										
20	30	24	8	26	6000	3102	✓	✓	✓	✓
28	30	24	8	26	6000	3103	✓	✓	✓	✓
36	30	24	8	26	6000	3104	✓	✓	✓	✓
<b>6" Diameter (150mm)</b>										
18	51	27	8	46	6000	5152	✓	✓	✓	✓
29	51	27	8	46	6000	5153	✓	✓	✓	✓
32	51	27	8	46	6000	5154	✓	✓	✓	✓
<b>8" Diameter (200mm)</b>										
26	80	40	10	75	4500	8202	✓	✓	✓	✓
37	80	40	10	75	4500	8203	✓	✓	✓	✓
45	80	40	10	75	4500	8204	✓	✓	✓	✓
<b>6" Diameter with LEAD CENTRE for taper spindle</b>										
25	Taper	32	X	X	2500	1608C/G	✓	✓	X	X
<b>8" Diameter with LEAD CENTRE for taper spindle</b>										
32	Taper	64	X	X	2200	1608CC	X	✓	X	X

**ORDER REF - WW**



## DEBURRING WHEELS

Convolute wheels for wood, veneers, plastic and all metals.

4 & 6" WHEELS - Come with a 1" centre hole

8" WHEELS - Come with a 3" centre hole

**Sold Individually**



### SELECT DENSITY

- 10 - Hardest keeps its shape even when working on stainless and titanium
- 9 - Hard the most widely used grade and is used on all hard steels for deburring
- 7 - Medium Softer and used for deburring softer steels and alloys

### DEBURRING WHEELS

WIDTH	DIAMETER		
	4" 100mm	6" 150mm	8" 200mm
1/2" or 12mm	✓	✓	✓
1" or 25mm	✓	✓	✓
2" or 50mm	✓	✓	✓

ORDER REF - BAR-WH



## FELT INSERT

All wheels can be fitted with a felt insert to allow use with tapered spindles or for straight spindles of different diameters.

**Sold Individually**

Available:

- 1" Centre Hole
- 2" Centre Hole
- 3" Centre Hole





**MX WHEELS**

Especially for fabricated stainless steel or aluminium alloys.

**MX Wheels** - specifically for grinding, polishing and weld blending of stainless steel and aluminium fabrications. Its unique cool grinding, fast cutting and exceptional finishing overcome the most difficult finishing operations.

- Very safe and easy to use.
- No abrasive loading on aluminium as with standard abrasive products, or glazing of abrasive on stainless steel.
- MC-FLEX or GFX

**MX FLAT SIDED WHEELS**

For die grinders, straight grinders, flexible drive shafts, bench grinders, polishing spindles.

Available in:

**Thickness:** 3mm, 6mm, 10mm

**Diameter:** 25mm, 50mm, 75mm, 100mm, 150mm, 200mm

**Standard Grits**

36, 54, 80, 120, 180

**ARTIFEX FINGER RING CONES**

Elastic rubber-bonded abrasive finishing cones, for roughing out the inside of rings and bores.

Sold Individually

**ARTIFEX WHEELS**

Silicon Carbide abrasive grit finishing wheels.

- **New super hard bonding now available**
- **NK for hard metals**

Sold Individually



**GRINDING**

ARTIFEX WHEELS			
GRADE MP, Medium/Hard Elastic			
Diameter x Width x Bore (mm)	Grit	Max.Safe	
		RPM	
50 x 25 x 6	24~150	7660	✓
	250~400		✓
100 x 25 x 13	24~150	3830	✓
	250~400		✓
150 x 15 x 13	24~150	2550	✓
	250~400		✓
150 x 25 x 13	24~150	2550	✓
	250~400		✓
Grits available: 24 46 80 150 250 400			
ORDER REF - ART-(SIZE)			

ARTIFEX FINGER RING CONES				
Grade	Grit	Hardness	Colour Code	
<b>Hard Bond</b>				
SC80HP	Coarse 80g	Hard	White	✓
SC150HP	Medium 150g	Hard	Red	✓
SC250HP	Fine 250g	Hard	Blue	✓
<b>Medium Bond</b>				
SC80MP	Coarse 80g	Med/Hard	White	✓
SC150MP	Medium 150g	Med/Hard	Red	✓
SC250MP	Fine 250g	Med/Hard	Blue	✓
SC400MP	Ex-Fine 400g	Med/Hard	Yellow	✓
SIZE: 83mm long x 22/15mm diameters				
Maximum Safe RPM: 10,000				
ORDER REF - ARTFC				

ARTIFEX WHEELS			
GRADE HP, Hard Elastic			
Diameter x Width x Bore (mm)	Grit	Max.Safe	
		RPM	
50 x 25 x 6	24~150	9950	✓
	250		✓
100 x 25 x 13	24~150	4500	✓
	250		✓
150 x 15 x 13	24~150	3200	✓
	250		✓
150 x 25 x 13	24~150	3200	✓
	250		✓
Grits available: 24 46 80 150 250			
ORDER REF - ART-(SIZE)			



RODA is a superior range of polishing and deburring products, for precision finishing, manufactured in the UK. RODA products consistently over-deliver on performance and efficiency.

# RODA NYMOP



GRINDING

### RODA NyMops

The Lap Disk Mop with a difference, unlike any other current nylon mop, RODA offers both deburring and finishing excellence using specially formulated technology. Time tested by industry professionals. Available in various grades to suit the material and required finish.



RODA NyMop								
SIZE	C80 HDVCA	C100 BROWN	C110 BLACK	C120 HDMA	M180 CA	M320 MA	M400 GREEN	F600 GREY
3" dia x 1-lap	✓	✓	✓	✓	✓	✓	✓	✓
3" dia x 2-lap	✓	✓	✓	✓	✓	✓	✓	✓
3" dia x 4-lap	✓	✓	✓	✓	✓	✓	✓	✓
3" dia x 6-lap	✓	✓	✓	✓	✓	✓	✓	✓
4" dia x 1-lap	✓	✓	✓	✓	✓	✓	✓	✓
4" dia x 2-lap	✓	✓	✓	✓	✓	✓	✓	✓
4" dia x 4-lap	✓	✓	✓	✓	✓	✓	✓	✓
4" dia x 6-lap	✓	✓	✓	✓	✓	✓	✓	✓
6" dia x 1-lap	✓	✓	✓	✓	✓	✓	✓	✓
6" dia x 2-lap	✓	✓	✓	✓	✓	✓	✓	✓
6" dia x 4-lap	✓	✓	✓	✓	✓	✓	✓	✓
6" dia x 6-lap	✓	✓	✓	✓	✓	✓	✓	✓
8" dia x 1-lap	✓	✓	✓	✓	✓	✓	✓	✓
8" dia x 2-lap	✓	✓	✓	✓	✓	✓	✓	✓
8" dia x 4-lap	✓	✓	✓	✓	✓	✓	✓	✓
8" dia x 6-lap	✓	✓	✓	✓	✓	✓	✓	✓

ORDER REF - LDM(DIA)X(LAPS)(GRADE)

Material	Colour	Desc	Grade	Operation	Finish							
						PLASTICS	PRECIOUS METALS	BRASS	ALUMINIUM	MILD STEEL	STAINLESS STEEL	EXOTICS
F600	Grey	UFS	600	Deburr Finish	A silicon carbide material offering a machine brush finish		●	●	●		●	
M400	Green	Green	400	Deburr Finish	A medium deburring and finishing material offering a machine brush finish		●	●	●		●	●
M320	Red	MA	320	Deburr Finish	A medium material offering removal of slight machine lines, whilst leaving a satin finish			●	●		●	●
C180	Red	CA	180	Deburr Finish	A coarse material offering removal of slight machine lines, whilst leaving a satin finish			●	●		●	●
C120	Red	HDMA	120	Deburr Finish	A coarse material offering removal of heavier machine lines, whilst leaving a brush finish				●		●	●
C110	Black	BLACK	110	Deburr Finish	A silicon carbide material with great cutting properties to remove deep machine lines and offer a bright finish				●	●	●	●
C100	Brown	BROWN	100	Deburr Finish	A superior coarse material offering graining ability as well as deburring, offering a a bright brush finish on all metals				●	●	●	●
C80	Red	HDVCA	80	Deburr	An extremely coarse grade for deburring / cleaning					●	●	●

**GRINDING**



**SPEEDS & FEEDS**

Diameter	Deburring max RPM at 30 m/s	Surface Prep max RPM at 25 m/s
3"	8,000	6,000
4"	6,000	5,000
6"	4,000	3,000
8"	3,000	2,500

# ABRASIVE NYLON FINISHING WHEELS



## ABRASIVE NYLON FINISHING WHEELS

Formed by radially bonding closely packed strips of abrasive nylon material to a core. Brushes are used for removing contaminants, scratches, decorative matt finishing and blending-in, prior to buffing operations with the finer grades. **Sold Individually**

### 4" (100MM) NYLON FINISHING WHEELS

Popular with jewellers for cleaning up castings.

**Sold Individually**



4" JEWELLERS FINISHING WHEELS				
Diameter (mm)	Width (mm)	Bore Dia. (mm)	Max RPM	
100	25	Taper	6,500	✓
Available in Fine A or Very Fine A & Super Cut				
ORDER REF - SCOTFW100X25(GRADE)				

### 6" (150MM) NYLON FINISHING WHEELS

Optional felt centre.

**Sold Individually**



6" (150mm) LARGE FINISHING WHEELS				
Diameter (mm)	Width (mm)	Bore Dia. (mm)	Max RPM	
150	25	50	3,400	✓
Available in Heavy Duty Coarse A, Heavy Duty Medium S, Heavy Duty Fine A				
ORDER REF - BAR-FINWH				

### 8" (203MM) NYLON FINISHING WHEELS

Large finishing wheels. Optional felt centre.

**Sold Individually**



8" (203mm) LARGE FINISHING WHEELS				
Diameter (mm)	Width (mm)	Bore Dia. (mm)		
200	45	75		✓
Available in Medium A, Fine A or Very Fine A				
ORDER REF - SCOTFW				

### ABRASIVE NYLON 'PLEATED' BIAS MOP

With closed centre for taper spindle.

**Sold Individually**



SIZE	AIRWAY BIAS MOPS		
	VERY FINE A FINE A	MEDIUM A	COARSE A
8" x 2 sec	✓	✓	✓
8" x 3 sec	✓	✓	✓
8" x 4 sec	✓	✓	✓
10" x 2 sec	✓	✓	✓
10" x 3 sec	✓	✓	✓
10" x 4 sec	✓	✓	✓
ORDER REF -SCOTABM(DIA)X(LAPS)(GRADE)			

## NYLON FILAMENT WHEELS & BRUSHES

Abrasive nylon wheels and brushes to suit different tools. Popular for cleaning and deburring. Can be used in CNC machines for automated deburring. **Sold Individually**



ABRASIVE NYLON DISH BRUSHES						
ORDER REF	Diameter	Brush Length	Thread / Bore Dia	Max.RPM	Grit	
					120 Medium	
GVA-41	100mm	20mm	M10 x 1.5mm	8500	632-414	✓
GVA-44			M14 x 1.5mm			✓



ABRASIVE NYLON WHEELS (LOOSE TYPE)							
ORDER REF	Diameter	Width	Brush Length	Bore	Max.RPM	120 Medium	240 Fine
GWH-46	100mm	16mm	25mm	25mm	3500	✓	✓
GWH-68	150mm	25mm				✓	✓

GRINDING



## UNMOUNTED UNITIZED WHEELS

- All come with a 6mm centre hole unless otherwise advised (150mm weldcut wheels have a 22mm centre hole)
- Other sizes can be made to order.
- For use with a bench grinder or with an MM506 6mm mandrel
- 150mm for Fillet Weld Grinders - weld removal



See Page 146 for tool.

Ideal for use with our Flex Fillet Weld Machine



## MX FLEXCUT DISCS

The composition of the MX abrasive enables these depressed centred dishes to grind and finish in one operation. They are useful in a variety of applications on both ferrous and non-ferrous metals.

Sold Individually



## DEPRESSED CENTRE ANGLE GRINDER DISHES

A variety of depressed centre angle grinder dishes in non-woven for surface finishing and felt for polishing. Use with an angle grinder for efficient large scale polishing.

Sold Individually



UNMOUNTED UNITIZED WHEELS				
Diameter	Quantity	Thickness		
		3mm	6mm	10mm
25mm	PER 10	✓	✓	✓
30mm		✓	✓	✓
40mm		✓	✓	✓
50mm	EACH	✓	✓	✓
75mm		✓	✓	✓
100mm		✓	✓	✓
125mm		✓	✓	✓
150mm		✓	✓	✓

**150mm for weld removal and cleaning**  
ORDER REF - UNITWH

UNMOUNTED NORTON WHEELS	
Size (dia. x thickness)	Pack of 10
10 x 12mm	✓
12 x 12mm	✓
25 x 6mm	✓
25 x 25mm	✓
50 x 6mm	✓
76 x 6mm	✓

**100, 150, 200mm dia. Available**  
ORDER REF - e.g UNITWH-(e.g 25X25-2SF)

MX FLEXCUT DISCS		
Size	Grade	
4 1/2" x 7/8 DPC	A36	✓
4 1/2" x 7/8 DPC	A54	✓
7" x 7/8 DPC	A36	✓

ORDER REF - REXCUTFLEX

DEPRESSED CENTRE DISHES			
Material	Max RPM		ORDER REF
Felt Medium	10,300	✓	VFP
Non-Woven Red (80g) Grey (240g)	12,875	✓	VNP
Paint Stripping super black abrasive	12,875	✓	VGP

Select either M14 OR M10 thread

**DEPRESSED CENTRE PAINT STRIPPING DISHES**  
Not for polishing, these dishes remove paint and rust etc.  
Sold Individually

GRINDING



## GRINDING DISCS

For angle grinders– Maximum working speeds of 80 m/s.

Sold in Packs of 10



GRINDING DISCS			
Dia x thickness x bore (mm)	Pack Quantity	BF27 Metal	X24 Stainless
100 x 6 x 16	10	✓	✓
115 x 6 x 22		✓	✓
125 x 6 x 22		✓	✓

ORDER REF - GD(SIZE)

## CUT-OFF WHEELS

For off-hand cutting– Maximum working speed of 80 m/s.

Sold in Packs of 50



CUT-OFF WHEELS						
Dia x thickness x bore (mm)	Pack Quantity	Flat		Pack Quantity	Depressed Centre	
		F1 Metal	F24 Stainless		XF1 Metal	XF24 Stainless
100 x 1 x 16	25	X	✓	25	X	X
100 x 1.2 x 16		X	✓		X	X
100 x 2.5 x 16		✓	✓		✓	✓
115 x 2.5 x 22		✓	✓		✓	✓
125 x 2.5 x 22		✓	✓		✓	✓
178 x 3 x 22		20	✓		✓	✓
230 x 3 x 22	✓		✓	✓	✓	

ORDER REF - COW

### NORTON ATLAS RED - PER 25

NORTON ATLAS RED  
CUT OFF WHEELS



ORDER REF - COW115X1MM



### NORTON ATLAS RED CUT OFF WHEELS

Ultra thin discs with good cut rate and a good price / quality ratio. For general trade and general usage in stainless steel applications. Free of iron, sulphur and chlorine.

## FIBRE BACKED SANDING DISCS

For use on all portable right-angled sanders with backing pad.

For metal grinding.

**Sold in Packs of 50**



FIBRE BACKED SANDING DISCS					
Diameter x Bore	Pack Quantity	36 grit	60 grit	80 grit	120 grit
4819 Blue Zirconia					
100 x 16mm	50	✓	✓	✓	✓
115 x 22mm		✓	✓	✓	✓
125 x 22mm		✓	✓	✓	✓
178 x 22mm		✓	✓	✓	✓
ORDER REF - FBSD(SIZE)					
4570 CERAMIC ALUMINIUM OXIDE					
100 x 16mm	50	✓	✓	✓	✓
115 x 22mm		✓	✓	✓	✓
125 x 22mm		✓	✓	✓	✓
178 x 22mm		✓	✓	✓	✓
ORDER REF - FBSD(SIZE)					

## ARECAL ANGLE GRINDER MOPS

Poli mop - 115mm polishing mop for all metals.

A compacted micro fibre mop with flexible backing plate for polishing ALL METALS including stainless steel. Cleans residue, scratches, paints and coverings. Can also be used on wood and plastics.

**115mm (Available in grits 80, 180, 400)**

**Sold Individually**



ARECAL POLI MOPS - EACH	
115mm Dia	✓
ORDER REF - RECAPOLIMOP	

## ARECAL CUTTING DISCS

P F1i INOX CUTTING DISC 115 x 1.0 x 22.2mm - For stainless steel . Specialist Cutting Disc . The F1i is an all-new improved 1mm thick specialist disc for ultra fast cutting in stainless steel. The disc contains no impurities such as iron, chlorine and sulphur that contaminate stainless steel. The F1i gives 50% better performance and life when cutting stainless steel than the old F1. 80m/s, Max RPM. 13,300

**Sold Individually**



ARECAL CUTTING DISCS - EACH	
Arcal Cutting Discs	✓
ORDER REF - COW115X1X22.2-F1/I	

## MOLERODA DEPRESSED CENTRE DISHES

In Unitized material for surface preparation and Felt. Use with a backing pad (below) and angle grinder.

**Sold Individually**



MOLERODA DEPRESSED CENTRE DISHES		
Material		ORDER REF
Unitized Hard, Med, Soft	✓	UNIT-DPC
Felt 6mm Thick Med, Hard	✓	FED-DPC
Felt 12mm Thick Med, Hard	✓	FED-DPC
115mm Dia. (For M14 Backing Pad)		

GRINDING



# ANGLE GRINDER CONSUMABLES



## SURFACE CONDITIONING FLAP DISCS

Use for blending and surface preparation. Steel to Aluminium. Discs come in 4 different grades.



Sold Individually

SURFACE CONDITIONING FLAP DISCS			
DIAMETER (MM)	WIDTH	GRADE	
115mm	22	COARSE	✓
115mm	22	MEDIUM	✓
115mm	22	FINE	✓
115mm	22	VERY FINE	✓
ORDER REF - BAR-WH			

## ANGLE GRINDING BACKING PADS

page 75.

Sold Individually



GRINDING

## ABRASIVE FLAP DISCS

Zirconium Oxide grit. As abrasive flapdiscs wear down, the abrasive surface is constantly renewed. This provides a cooler grinding effect and avoids clogging, thus producing a better finish and less working time.

Sold Individually

## LV/LN FLAP WHEELS

Flat or angled Zirconium Oxide



### Abrasive flap discs can offer you:

- Reduced down-time
- Increased productivity
- Cooler sanding
- Improved Finish
- Lower cost (than fibre sanding discs)



## ZOOM FLAP WHEELS

Economically priced Angled Zirconium Oxide

ABRASIVE FLAPDISCS					
DIAMETER	REF	GRITS	SHAPE	MAX.RPM	
x BORE		AVAILABLE			
100 x 16mm	LVZ28	40 - 60 - 80 - 120	Flat	15,000	✓
100 x 16mm	LVZ29		Angled	15,000	✓
115 x 22mm	LNZ74		Flat	13,200	✓
115 x 22mm	LVZ34		Flat	13,200	✓
115 x 22mm	LVZ38		Angled	13,200	✓
178 x 22mm	LVZ66		Flat	8,500	✓
ORDER REF - FD(DIA)-Z(GRIT)-(REF)					
BEST QUALITY					
110 x 22mm	61Z	40 - 60 - 120	Flat	11,000	✓
ORDER REF - FD110MMZ(GRIT)					
DIAMETER	REF	Zoom Flap Discs	SHAPE	MAX.RPM	
x BORE		GRITS AVAILABLE			
115 x 22mm	ZOOM	60 - 80 - 120	Angled	8,500	✓
ORDER REF - FD115-ZOOM-Z(GRIT)					



**KEYWAY WHEELS**

100 X 100 x 19mm

Flap Wheel options:

- Interleaved
- Abrasive Nylon

For use with angle grinders with a keyway fitting. Especially good for flat plate finishing.

**Sold Individually**

ABRASIVE KEYWAY		
ABRASIVE NYLON WHEELS		
<b>100 x 100 x keyway</b>	Coarse, Medium, Fine, Very Fine	✓
ORDER REF - SCOTWH100		
INTERLEAVED FLAP WHEELS		
<b>100 x 100 x keyway</b>	60/F 100/F 150/F	✓
ORDER REF - IF-100		

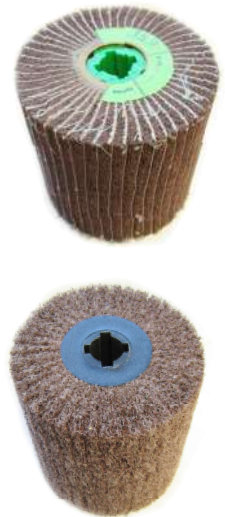

See Page 147 for tool.

**GRINDING**

**KEYWAY WHEELS**

100 X 100 x 19mm

Flap Wheel options:

- Aluminium Oxide

For use with angle grinders with a key way fitting. Especially good for flat plate finishing.

**Sold Individually**



ABRASIVE KEYWAY WHEELS		
Size	Grit/Grade	
COATED ABRASIVE FLAP WHEELS		
<b>100 x 100 x keyway</b>	40 50 60 80 100 120 150	✓
	180 220 240 320	✓
		✓
ORDER REF - FW100		

**LARGE ABRASIVE FLAP WHEELS**

Abrasive flap wheels with a wooden centre for use with a taper spindle.

Aluminium Oxide grit.

**Sold Individually**



LARGE FLAP WHEELS					
Dia. x Width	Grits Available				Max.RPM
	40/ 60	80 /120	180	240/ 320	
<b>165 x 25mm</b>	✓	✓	✓	✓	5,800
<b>165 x 50mm</b>	✓	✓	✓	✓	2,800
ORDER REF - FWWC					



## POLISHING CONSUMABLES

- P100 - 107 - MOUNTED POLISHING TOOLS
- P108 - 116 - UNMOUNTED POLISHING TOOLS
- P117 - POLISHING HAND TOOLS

## POLISHING

With Moleroda's 35 years' experience in manufacturing polishing consumables into industry, we are able to offer the quality products as well as the technical knowledge.

With a wide range of innovative tooling and consumables for polishing, we have an offering for every application. We offer various materials as well as various compounds to create the desired finish, whether this is a matt or a mirror finish.

For mirror finishing we offer all grades of felt tools and lapping sticks to accompany our range of diamond compound.

For the polishing mop users we manufacture all sizes of mops in every material required from 4" to 12" as well as being a global leader in polishing compound sales.

For the hobbyist's we offer a complete range of bobs, cones and points in that required smaller size to be able to polish your items with precision.

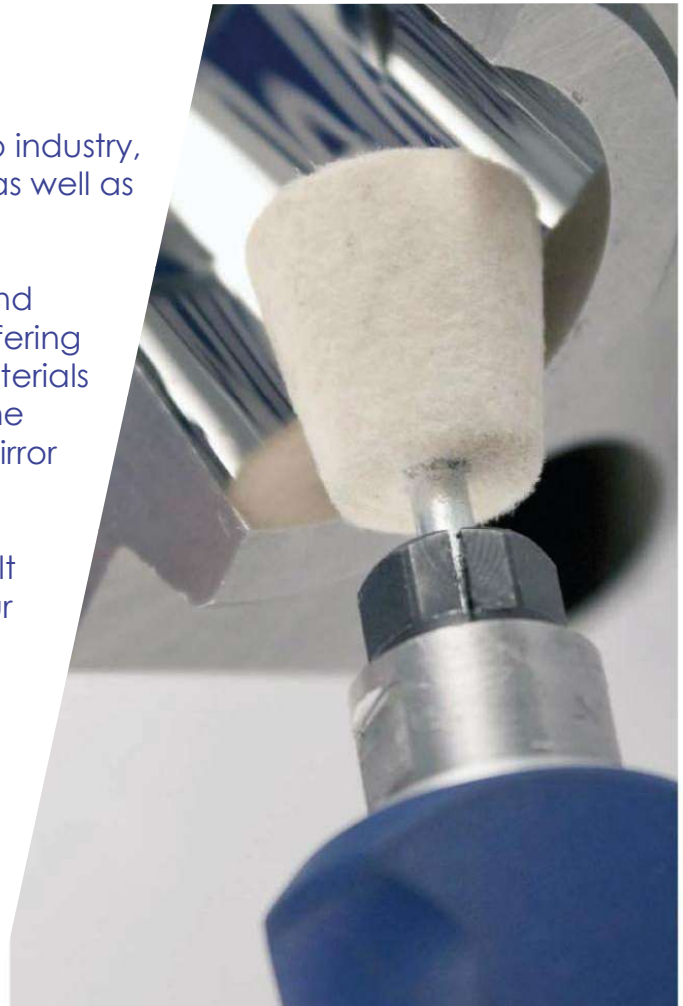



## POLISHING OVERVIEW

Once you have prepared your surface, start your polishing with mops and compound. Rule of thumb with compounds, dark ones are abrasive and pale ones are for finishing.

Start with a dry sisal if you have scratches to remove. Spin the mop against the cutting compound to load, if using a large hand tool like a drill or angle grinder it might help to clamp the compound to the table.

Work over the metal ensuring you keep moving not staying in any one place for too long.

Move on to the white stitched mop. At this point, you can either use a cutting compound or polishing compound.

Finally, use the WDR mop with the finishing compound to bring the finish up to a high shine.

To clean up dip a soft lint-free cloth in the Vienna lime and wipe over the metal. It will remove the polishing haze and bring the finish up to a high shine.

## POLISHING TIPS

**General points to take into consideration before you start to polish.**

- Determine where you start, this will depend on the state of the surface.
- What speed will your mops run at?
- What is the quality of your material?
- Removal of all previous process marks.
- Try not to overload your compound. It will leave it greasy.
- Correct PPE! Make sure you have masks and eye protection! If polishing at home without extraction try going outside.
- Consider degreasing solutions. Vienna lime or solvent removers work well.
- Do not wash your mops, you can buy mop dressers that will bring your mops back to life.
- Do not cross contaminate compounds. Keep one mop per compound.





## FELT LAPPING STICKS

Hardened or Unhardened  
Can be used in double-ended or hand held stone holders.

**Sold in Packs of 10**



FELT LAPPING STICKS			
Order Ref.	Size (mm)	100mm Hardened	150mm Hardened
FS6	6 sq	✓	✓
FS8	8 sq	✓	✓
FS10	10 sq	✓	✓
FS12	12 sq	✓	✓
FS25	25 sq	✓	✓
<b>Deduct 5% for Unhardened Sticks</b>			
<b>ORDER REF - FS</b>			

## MOUNTED FELT LAPPING STICKS

**Mounted on a 3mm or 1/8" spindle**

Mounted felt polishing sticks suitable for Diprofil-type reciprocator heads for diamond polishing.

**Sold in Packs of 10**



MTD FELT STICKS		
ORDER REF	Size (mm)	
FSM6	6 sq x 40 long	✓
FSM8	8 sq x 40 long	✓
FSM10	10 sq x 40 long	✓
FSM12	12 sq x 40 long	✓
<b>Deduct 5% for Unhardened Sticks</b>		

## FELT RECTANGLES

Felt rectangles for hand finishing with diamond compound, Simichrome etc. Also good for cleaning after polishing.

**Sold in Packs of 10**



FELT RECTANGLES			
Order Ref.	Size (mm)	Soft/Medium	Hard
FR2550	25 x 50 x 3	✓	✓
FR50100	50 x 100 x 3	✓	✓
<b>ORDER REF - FR...</b>			

## FELT HAND FILES

Felt hand files for use with diamond paste, Ultralap or Simichrome. Perfect for a high finish on flat surfaces.

**Sold individually**

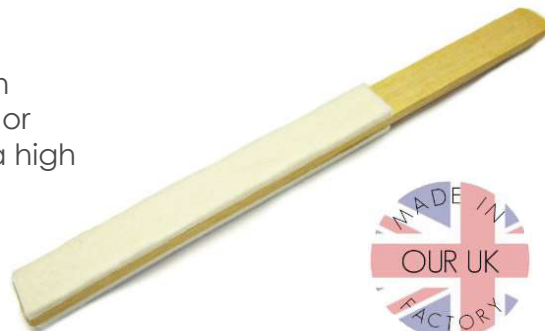

FELT HAND FILES		
FELT	Available Grades	
Single Sided	Soft, Medium or Hard	✓
Double Sided		✓
<b>ORDER REF - WHF-F</b>		





## SUPER LAPPING STICKS

For use with diamond and lapping pastes

- Very strong and hard - maintains shape
- Excellent for polishing and lapping
- No scratching or splintering
- Sizes to fit ceramic stone holders
- Ideal for filers and Diprofiles

Sold in Packs of 10



SUPER LAPPING STICKS					
1mm thick		2mm thick		3mm thick	
2 x 1mm	✓	4 x 2mm	✓	3mm sq.	✓
3 x 1mm	✓	6 x 2mm	✓	6 x 3mm	✓
4 x 1mm	✓	8 x 2mm	✓	-	
6 x 1mm	✓	12 x 2mm	✓		
10 x 1mm	✓	-			
12 x 1mm	✓	6mm thick		8mm thick	
4mm thick		6mm sq.	✓	12 x 8mm	✓
4mm sq.	✓	12 x 6mm	✓	19 x 8mm	✓

ORDER REF - SULS

## MOUNTED LAPPING STICKS/BOBS & CONES

- Hard or soft wood
- Mounted on a 3mm spindle

Excellent for use in a reciprocating tool for polishing a flat surface or into a slot.

Sold in Packs of 10



MTD WOODEN CONES			
Dia x Length	Hard	Soft	
6 x 16mm	✓	✓	
8 x 16mm	✓	✓	
12 x 30mm	✓	✓	

ORDER REF - HWC/SWC

MTD WOODEN BOBS			
Dia x Length	Hard	Soft	
6 x 12mm	✓	✓	
8 x 16mm	✓	✓	
12 x 20mm	✓	✓	

ORDER REF - HWB/SWB

MTD WOODEN LAPPING STICKS			
Size	Hard	Soft	
ROUND			
6mm dia.	✓	✓	
8mm dia.	✓	✓	
SQUARE			
6mm sq.	✓	✓	
8mm sq.	✓	✓	

ORDER REF - MHWS /MSWS

## WOODEN LAPPING STICKS

Low cost -High quality, soft or hard wood. Round sticks with a pointed end ideal for fine detail. For hand or machine use. Choose hardwood for greater cut.

Sold in Packs of 10



SQUARE			
Size	Hard	Soft	
3mm	✓	✓	
4.5mm	✓	✓	
6mm	✓	✓	
8mm	✓	✓	

ORDER REF HWLS SWLS

ROUND			
Size	Hard	Soft	
3mm	✓	✓	
4.5mm	✓	✓	
6mm	✓	✓	
8mm	✓	✓	
10mm	✓	✓	
12.7mm	✓	✓	

ORDER REF HWLS SWLS

RECTANGULAR			
Size	Hard	Soft	
4.5 x 3mm	✓	✓	
6 x 3mm	✓	✓	
6 x 4.5mm	✓	✓	
8 x 6mm	✓	✓	
9 x 3mm	✓	✓	
12 x 6mm	✓	✓	
12 x 8mm	✓	✓	
19 x 6mm	✓	✓	
19 x 8mm	✓	✓	
25 x 6mm	✓	✓	

ORDER REF HWLS SWLS

POLISHING



RODA is a superior range of polishing and deburring products, for precision finishing, manufactured in the UK. RODA products consistently over-deliver on performance and efficiency.

# RODA FELT



POLISHING

MOUNTED FELT - BOBS, CONES & BULLNOSE					
Dia x Length (mm)	Shank Diameter				
	3/32"	3mm	1/8"	6mm	1/4"
6 x 12	✓	✓	✓	X	X
10 x 12	X	✓	✓	X	X
10 x 25	X	✓	✓	X	X
12 x 12	X	✓	✓	✓	X
12 x 25	X	✓	✓	✓	✓
16 x 25	X	✓	✓	✓	✓
20 x 20	X	✓	X	✓	X
20 x 25	X	✓	✓	✓	X
25 x 25	X	X	X	✓	✓
30 x 35	X	X	X	✓	X

Extra charge for Hardening +10%

Other sizes and spindle diameters are available

ORDER REF - MFB/MFC/MFBN(DIA) X(LENGTH)-(SPINDLE)

### RODA Felt:

The Professional Polishers tool of choice. Over 30 years of experience and knowledge has been used to develop a quality product like no other. Designed and manufactured in the UK alongside polishing specialists, RODA Felt is the market leader in specialist finishing.



### Felt Density

**Medium-** Ideal for cutting and polishing operations, this is a good standard felt for most materials.

**Chemically hardened-** Standard felt is treated to make it hard and less flexible. It gives you more cut and therefore particularly suits harder metals. Shaped felts are more likely to keep their shape when hardened.



Extended spindles are also available. – More spindle sizes and bespoke sizes are available please call us.



**SMALL MOUNTED FELT BOB KIT**

Metric (3mm) or Imperial (1/8") spindle option. A mixture of shapes; conical, bullnose and bobs in various dimensions.

**Sold in Packs of 10**

LARGE MTD FELT BOB KIT	
(Imperial or Metric)	✓
ORDER REF - MFBKITL(IMP OR MET)	



**LARGE MOUNTED FELT BOB KIT**

Metric (3mm & 6mm) or Imperial (1/8" & 1/4") spindle option. A mixture of shapes; conical, bullnose and bobs in various dimensions.

**Sold in Packs of 10**

SMALL MTD FELT BOB KIT	
(Imperial or Metric)	✓
ORDER REF - MFBKITS(IMP OR MET)	

**What do you use mounted felt bobs for?**

Felt bobs are mainly used for polishing metal although you can also use them on glass. These bobs are used in many industries including:

**Mould tool polishing:** – Mould tools and dies used for plastic injection require a very high finish. You'll find that felt is mostly used for lapping and polishing with diamond compound.

**Polishing medical implants** – Moleroda have been making bespoke felts for medial companies for many years- Our felts are very high quality, under totally controlled manufacturing, suitable for robotic use.

**Polishing precision engineered components** – we supply aerospace, automotive, oil and gas, defence, and many more engineering industries. Anything where you require a polished finish.

**Polishing precious metals in Jewellery industry** – Working on gold and silver, Platinum, Palladium etc. Jewellers usually require smaller felts on a 2.35mm spindle with fine compounds such as Rouge.

**POLISHING**

**SPEEDS & FEEDS**



Diameter	Deburring max RPM at 30 m/s	Surface Prep max RPM at 25 m/s	Polishing Fine 3 Micron or less at 1.5 m/s
<b>6mm</b>	8,000	6,000	4,000
<b>8mm</b>	6,000	5,000	3,000
<b>10mm</b>	5,000	4,000	3,000
<b>12mm</b>	4,000	3,000	2,000
<b>25mm</b>	3,000	2,000	2,000

## MOUNTED DENTAL FELTS

All dental felts are on a 2.35mm spindle. Ideal for detail polishing when used with compound.

**Sold in Packs of 10**



DA0811 DA0914 DB0811 DB1015 DC0714 DD0606 DD0808 DD1010



DE0510 DE0716 DF0408 DF0510 DG0812 DG1014 DH1314 DH1314 DP0502

MTD DENTAL FELTS (on 2.35mm)		
Order ref.	Dia (x Dia) x Length (mm)	Pack of 10
DA 0811	8 x 5 x 11	✓
DA 0914	9.5 x 8 x 14	✓
DB 0811	8 x 5 x 11	✓
DB 1015	10 x 6 x 15	✓
DC 0714	7 x 14	✓
DD 0606	6	✓
DD 0808	8	✓
DD 1010	10	✓
DE 0510	5 x 10	✓
DE 0716	7.5 x 16	✓
DF 0408	4 x 8	✓
DF 0510	5 x 10	✓
DG 0812	8 x 6 x 12	✓
DG 1014	10 x 6 x 14	✓
DH 1314	13 x 8 x 14	✓
DJ 1019	10 x 8 x 19	✓
DP 0520	5-1 x 20 (cone)	✓
<b>Extra charge for Hardening +10%</b>		
<b>ORDER REF - MF-D...</b>		
<b>17 PIECE ASSORTMENT</b>		✓
<b>ORDER REF - MFBKITDENTALSET</b>		

POLISHING

## DENTAL FELT SET

A set containing the full 17 assorted dental felt shapes on a 2.35mm shank.

**Sold in Packs of 17**

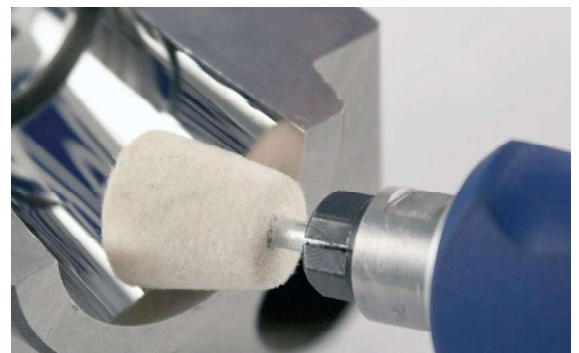

## OTHER SHAPED FELTS

Other specialist shapes are available designed for awkward to polish areas, shaped to perform particular tasks. For pricing and ordering please contact us.

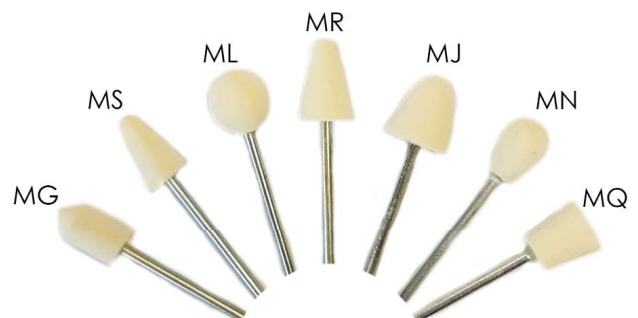



## MOUNTED FELT WHEELS

Mounted felt wheels in a full range of thicknesses, densities mounted on spindles. Used for polishing with compound.

**Sold in Packs of 10**



MTD FELT WHEELS						
Wheel Thickness	Grade	Max RPM	WHEELS			
			22mm	25mm	30mm	40mm
2.35mm Shank						
3mm	Medium	13,000	✓	✓	X	X
4.5mm			✓	✓	X	X
6mm			✓	X	X	X
ORDER REF - VSM-(DIA)X(THICKNESS)						

3mm Shank						
3mm	Medium	13,000	-	✓	✓	✓
3mm	Hard			✓	✓	✓
6mm	Medium			✓	✓	✓
10mm	Soft/Medium	5,000	-	✓	✓	✓
10mm	Medium			X	✓	X
10mm	Hard			✓	✓	✓
ORDER REF - (DIA)X(THICKNESS)						

MTD 3-LAP FELT WHEELS						
Shank		Max RPM	22mm	25mm	30mm	40mm
2.35mm	Soft	14,000	✓	✓	X	X
ORDER REF - VSM-(DIA)X3LX3/32FW						
3mm	Soft	14,000	X	✓	✓	✓
ORDER REF - (DIA)X3L-3FELT-SOFT						

## MOUNTED KNIFE EDGE WHEELS

Made from hardened felt, these wheels are good for accessing difficult to polish areas when employed with compound.

**Sold in Packs of 10**



MTD FELT KNIFE EDGE WHEELS - PER10					
Shank	WHEEL DIA (mm)				
	22mm	25mm	30mm	40mm	Max RPM
2.35mm	✓	X	X	X	12,000
ORDER REF - VSM-7/8KE					
3mm	X	✓	✓	✓	12,000
ORDER REF - (DIA)-3KNIFE-EDGE					

## MOUNTED FELT FLAP WHEELS

Extremely good for polishing inside bores and convoluted surfaces.

**Sold Individually**

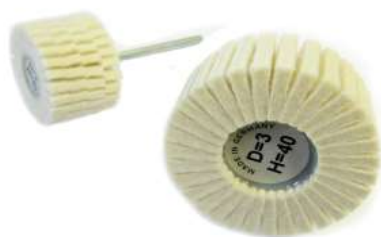

MTD FELT FLAP WHEELS - EACH				
Spindle	Diameter mm	Width mm	Felt Thickness	
3mm	20	10	2mm	✓
	30	10		✓
	30	20		✓
6mm	50	20	3mm	✓
	60	30		✓
	80	50		✓
ORDER REF - MFFW				

# MOUNTED FELT BUFFING BALLS & MOPS



## SMALL & LARGE MOUNTED BUFFING BALLS

The ball shape gives the top washer more coverage allowing you to use the top of the ball as well as the sides without scratching. Twice as much material for a longer lasting product. Small felt buffing balls on 2.35mm and 3mm spindles. Large diameters on a 6mm re-usable shank. The screw mandrel allows laps to be replaced and the reverse threaded mandrel won't loosen during use. Replacement laps for large buffing balls make this product extremely economical.



FELT BUFFING BALLS									
Material	6mm	12mm	22mm	25mm	30mm	40mm	50mm	75mm	100mm
<b>Small Mounted Buffing Balls - 2.35mm Spindle - Per 10</b>	✓	✓	X	✓	X	X	X	X	X
ORDER REF - VSM-(DIA)X6LX3/32-(MATERIAL)									
<b>Small Mounted Buffing Balls - 3mm Spindle - Per 10</b>	X	X	X	✓	✓	✓	X	X	X
ORDER REF - (DIA)X6LAP-3MM(MATERIAL)									
<b>Large Mounted Buffing Balls - 6mm Spindle - Each</b>	X	X	X	X	X	X	✓	✓	✓
<b>Large Mounted Buffing Ball Refills - 20 Laps</b>	X	X	X	X	X	X	✓	✓	✓
ORDER REF - (DIA)X6LAP-3MM(MATERIAL)									

POLISHING

## MOUNTED CHAMOIS WHEELS

On 2.35mm or 3mm spindles. 100% high quality chamois leather. Made in our factory in various diameters. Particularly useful on glass and precious metals.

Sold in Packs of 10



Shank	Laps	WHEELS				
		19mm	22mm	25mm	30mm	40mm
2.35mm	4-Lap Chamois	✓	✓	✓	X	X
3mm	8-Lap Chamois	X	X	✓	✓	✓

## MOUNTED CALICO MOPS

Come in hard, medium and soft (white) on a 2.35mm and 3mm spindle. Used with compound for all stages of polishing. Max RPM 12,000.

Sold in Packs of 17



MTD CALICO WHEELS - PER 10					
Shank	Material	WHEELS			
		22mm	25mm	30mm	40mm
2.35mm	Hard Calico (12-lap)	✓	✓	X	X
	Medium Calico (16-lap)	✓	✓	X	X
	Soft Calico (16-lap)	✓	✓	X	X
ORDER REF - VSM-(DIA)X(LAPS)LX3/32-(H,M or S)					
3mm	Hard Calico (16-lap)	X	✓	✓	✓
	Medium Calico (24-lap)	X	✓	✓	✓
	Soft Calico (24-lap)	X	✓	✓	✓
ORDER REF - (DIA)X(LAPS)L-3CALICO(H,M or S)					



## MOUNTED MINI MOPS

Come in dry sisal, stitched G and stitched WDR on a 2.35mm and 3mm spindle. Used with compound for all stages of polishing. Max RPM 12,000.

Sold in Packs of 10



MTD MINI MOPS						
		2.35mm Mandrel		3mm Mandrel		
Width	Type	25mm Ø	30mm Ø	25mm Ø	30mm Ø	40mm Ø
4mm	Stitched G	X	✓	X	✓	X
	Dry Sisal	X	✓	X	✓	X
6mm	Stitched G	✓	✓	✓	✓	✓
	Stitched WDR	✓	✓	✓	✓	✓
12mm	Dry Sisal	X	✓	X	✓	X
	Stitched G	X	✓	X	✓	✓
	Stitched WDR	X	✓	X	✓	✓
ORDER REF		VSM - (DIA) X (WIDTH) -3/32 (TYPE)		(DIA) X (WIDTH) -3 (TYPE)		

## SMALL MOUNTED CUPS, WHEELS & PENCILS

Brass, Steel, Bristle, Hair and Nylon. These points are particularly useful for detail polishing & deburring.

Sold in Packs of 10



POLISHING

MOUNTED POLISHING WHEELS - 3mm SPINDLE								
Material	WHEELS			CUPS			PENCILS	
	20mm	25mm		10 x 7mm	12 x 3mm	15 x 8mm	5 x 6mm	6 x 8mm
Black Bristle	X	X		✓	✓	X	✓	✓
Mixed Hair	✓	X		X	X	X	X	✓
Material	17mm	19mm	21mm					
White Nylon	✓	✓	✓	X	X	X	X	X
ORDER REF - VSM3MM-(SIZE)-(TYPE)								

MOUNTED POLISHING WHEELS - 2.35mm SPINDLE									
Material	WHEELS				CUPS			PENCILS	
	17mm	19mm	22mm	25mm	6mm	10mm	12mm	4.5mm	6mm
Horsehair, Medium	X	X	✓	X	✓	X	✓	✓	X
Grey Goat Hair, Soft	✓	X	✓	X	X	X	✓	X	X
White Hair, Soft	X	X	✓	X	✓	X	✓	X	X
Black Bristle, Stiff	X	X	✓	X	✓	X	✓	✓	✓
White Bristle, Stiff	X	✓	✓	X	✓	✓	✓	✓	✓
White Nylon	X	X	✓	X	X	X	✓	✓	✓
Cotton Yarn Wheel	X	X	✓	✓	X	X	X	X	X
ORDER REF - SM-(SIZE)-(TYPE)									

## SMALL UNMOUNTED FELT & TAPERS



### UNMOUNTED FELT ROLLERS

Unmounted felt rollers for polishing, these rollers are very versatile and can be used for a huge variety of applications. The roller shape is ideal for getting into tight areas, for polishing in grooves, gaps etc. Don't see what you need? Contact us as we can make to your specification.

**Sold Individually**

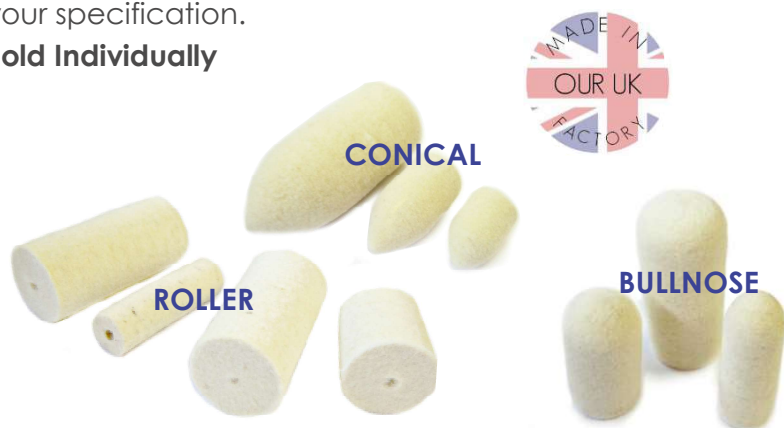

### UNMOUNTED FELT TAPERS

Normally used for polishing inside bores, felt tapers are particularly used in the Jewellery trade for polishing inside rings. Size options are: Overall Length x Bottom Diameter x Top Diameter in mm.

**Sold Individually**



UNMOUNTED FELT ROLLERS, BULLNOSE & CONES

Dia x Width (mm)	ROLLERS	BULLNOSE & CONES
Packs of 20		
6 x 12	✓	✓
12 x 12	✓	✓
12 x 20	✓	✓
12 x 25	✓	✓
12 x 40	✓	✓
16 x 20	✓	✓
20 x 20	✓	✓
20 x 25	✓	✓
20 x 40	✓	✓
20 x 45	✓	✓
20 x 56	✓	✓
22 x 32	✓	✓
22 x 45	✓	✓
22 x 50	✓	✓
22 x 56	✓	✓
25 x 25	✓	✓
25 x 40	✓	✓
25 x 50	✓	✓
Individually		
40 x 50	✓	✓
For Hardened, + 20% For 2-stage lead hole, + £0.20 per unit		
ORDER REF - FER / FEC / FEB - (DIMENSIONS)		

UNMOUNTED FELT TAPERS

Length (mm)	Large Dia.	Small Dia.	
20	16	10	✓
20	20	12	✓
25	12	8	✓
32	20	12	✓
40	12	8	✓
40	20	12	✓
40	25	12	✓
45	20	10	✓
50	20	10	✓
50	22	12	✓
50	25	12	✓
56	25	12	✓
63	20	10	✓
63	25	12	✓
75	25	12	✓
100	25	12	✓
For Hardening +10% For 2-stage lead hole, + £0.20 each			
ORDER REF - FET-(DIMENSIONS)			

POLISHING



## MOUNTED RING FELTS

Used for polishing inside rings.

**Sold Individually**



MOUNTED RING FELTS	
Size	
STANDARD	
3"	✓
3.1/2"	✓
4"	✓
SOFT	
4"	✓
HARD	
3"	✓
3.1/2"	✓
4"	✓
ORDER REF - MRF	

## COTTON RING BUFF

Used for the final polishing of the inside of rings. **Sold Individually**

COTTON RING BUFFS		
Ref.	Size (mm)	
CRB-01	110 x 65 x 14/29 (standard)	✓
CRB-02	115 x 75 x 16/32 (large)	✓
CRB-03	110 x 70 x 15/27 (large-slim)	✓
CRB-04	110 x 70 x 12/22 (slim)	✓
ORDER REF - MCRB-CRB-(No)		



## WOODEN RING HOLDER

For the mounting and holding of rings when polishing their outer surface.

**Sold Individually**



WOODEN RING HOLDER
✓
ORDER REF - WOODENRINGHOLDER

## COMBINATION RING FELTS

Size: Mounted felt length -87mm  
Wheel dia x thickness - 63 x 12mm  
Used for polishing both inside and outside rings/bores.

**Sold Individually**



COMBINATION RING FELT/WHEEL
✓
ORDER REF - MRF-W



## SPLIT LAP FELT WHEELS

Each wheel has 1/4" radial slits, which, when rotated at high speeds, they allow the operator to see through the wheel to the object being polished. The purpose of this system is the operator's line of sight is through the wheel, the radial slits providing a window of the surface being polished and therefore the item does not have to be removed for inspection.

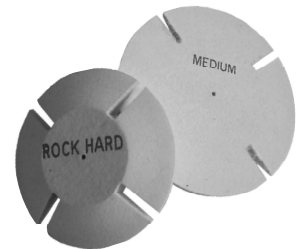

## UNMOUNTED KNIFE EDGE / BEVELLED EDGE FELT WHEELS

Hardened felt wheels.

**Sold Individually**

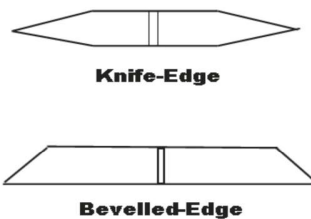

KNIFE EDGE WHEELS	
Diameter (mm)	
12mm THICK	
40	✓
50	✓
63	✓
75	✓
86	✓
100	✓
125	✓
150	✓
5% price reduction for Unhardened Wheels	
ORDER REF - KEW or BEW	

POLISHING

# FELT DISCS, RINGS & UNMOUNTED WHEELS



## SOFT FELT DISCS & RINGS

For high quality diamond polishing. For harder density felt material, + 10% to standard prices

Sold in Packs of 20



FELT RINGS	
(for flexible holders)	
Size	
20 x 6 CH	✓
30 x 10 CH	✓
52 x 25 CH	✓
ORDER REF - SAR(DIA.)-FELT	

FELT DISCS	
Diameter	
10mm	✓
12mm	✓
20mm	✓
25mm	✓
30mm	✓
50mm	✓
75mm	✓
ORDER REF - SAD(DIA.)-FELT	

## UNMOUNTED FELT WHEELS

Extra charge for hardening +10%

Extra charge for washing + £0.50 per wheel

All wheels supplied with a standard 6mm centre hole.

Extra charge for non-standard centre hole + £1.00 per wheel.

Other sizes and densities available, but may be subject to minimum order quantities, price on application.



Sold Individually



POLISHING

UNMOUNTED FELT WHEELS	
Dia x Width (mm)	
50 x 12	✓
50 x 20	✓
50 x 25	✓
50 x 40	✓
50 x 50	✓
50 x 75	✓
63 x 12	✓
63 x 25	✓
63 x 40	✓
63 x 50	✓
75 x 10	✓
75 x 12	✓
75 x 20	✓
75 x 25	✓
75 x 40	✓
75 x 50	✓
75 x 75	✓
ORDER REF - FEW	

UNMOUNTED FELT WHEELS				
Dia x Width (mm)	SOFT SG45	MEDIUM SG55	HARD SG66	
100 x 6	✓	✓	✓	
100 x 10	✓	✓	✓	
100 x 12	✓	✓	✓	
100 x 20	✓	✓	✓	
100 x 25	✓	✓	✓	
100 x 40	✓	✓	✓	
100 x 50	✓	✓	✓	
125 x 6	✓	✓	✓	
125 x 12	✓	✓	✓	
125 x 20	✓	✓	✓	
125 x 25	✓	✓	✓	
125 x 40	✓	✓	✓	
125 x 50	✓	✓	✓	
150 x 6	✓	✓	✓	
150 x 12	✓	✓	✓	
150 x 20	✓	✓	✓	
150 x 25	✓	✓	✓	
150 x 40	✓	✓	✓	
150 x 50	✓	✓	✓	
150 x 75	✓	✓	✓	
ORDER REF - FEW				

UNMOUNTED FELT WHEELS				
Dia x Width (mm)	SOFT SG45	MEDIUM SG55	HARD SG66	
200 x 6	✓	✓	✓	
200 x 12	✓	✓	✓	
200 x 20	✓	✓	✓	
200 x 25	✓	✓	✓	
200 x 40	✓	✓	✓	
200 x 50	✓	✓	✓	
200 x 75	✓	✓	✓	
250 x 6	✓	✓	✓	
250 x 12	✓	✓	✓	
250 x 20	✓	✓	✓	
250 x 25	✓	✓	✓	
250 x 40	✓	✓	✓	
250 x 50	✓	✓	✓	
250 x 75	✓	✓	✓	
300 x 6	✓	✓	✓	
300 x 12	✓	✓	✓	
300 x 20	✓	✓	✓	
300 x 25	✓	✓	✓	
300 x 40	✓	✓	✓	
300 x 50	✓	✓	✓	
300 x 75	✓	✓	✓	
ORDER REF - FEW				

## MISCELLANEOUS FELT PRODUCTS

Bespoke felts made to customer specifications. We can problem solve to create the ideal polishing solution however complex. This is what we do best.

### PADS & BLOCKS

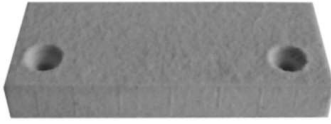

**SPECIAL FABRICATIONS**



### RINGS & SEALS



Inserts and spigots can be added during manufacture

### FELT PLUG ASSISTS

A fast, low-cost alternative to Aluminium, Durillium and wooden plugs. Felt is durable with rapid warm-up.



**BEATERHEADS**

### FELT ROLL

High quality felt available by the meter.

**Sold in Square Metres**

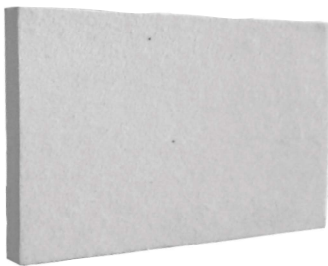

### WHITE PRESSED FELT SHEET

High quality felt available by the metre.

**Sold in Square Metres**



### MEDICAL FELTS

Specially made to suit automated/robotic polishing systems



**POLISHING**

## FELT ORDERING SPECIFICATION – HOW TO ORDER FELTS

**FELT ROLLER** - Diameter x Length x Density

**FELT WHEEL** - Diameter x Width x Density

**CONICAL FELT** - Diameter x Length x Density

**BULLNOSE FELT** - Diameter x Length x Density

**MOUNTED BOB** - Diameter x Length x Spindle diameter x Density

**MOUNTED CONICAL FELT** - Diameter x Length x Spindle Diameter x Density

**MOUNTED BULLNOSE FELT** - Diameter x Length x Spindle Diameter x Density

**UNMOUNTED RING FELT/TAPER** - Length x Large Diameter x Small Diameter x Centre Hole x Density

**MOUNTED RING FELT** - Length x Density

**BEVEL WHEEL** - Diameter x Width, Hardened or Unhardened

**KNIFE EDGE WHEEL** - Diameter x Width, Hardened or Unhardened

## LOOSEFOLD POLISHING MOPS

### Sold Individually

Polishing aluminium, stainless steel, brass, copper, gold and silver nearly always require mops and compounds to create a mirror shine.



SOFTEST - HARDEST

**WFC** - Very hard. Fast cutting polishing mop. Good for making rigid abrasive scurfs.

**Bronco** - Hard (yellow) Fast cutting mop where more flexibility is required. Soft feel for finishing. Makes a good abrasive scurf with some flexibility. A good one operation mop.

**B** - Medium/Hard. Good cutting mop for non-ferrous metals. Makes a good scurf – more flexible than 6G, especially in narrower sizes.

**G** - Most popular Medium, general purpose finishing mop with finishing compounds. Good for rougeing where little cut is required.

**WDR** - Soft. A raised one-sided lint finish mop, excellent for silver rouge finishing. Brush free finish if used at correct peripheral speed. Most popular.

**WHR** - Soft Swansdown. An all round finishing mop for all metals. A must for precious metals.

**Reflex** - Soft rougeing mop for finishing gold and especially silver – no rouge burn into silver.

### LOOSEFOLD POLISHING MOPS

SIZE	WFC	BRONCO	B	G	WDR	WHR	REFLEX
3 x 1/2"	✓	✓	✓	✓	✓	✓	✓
3 x 1"	✓	✓	✓	✓	✓	✓	✓
3 x 1.1/2"	✓	✓	✓	✓	✓	✓	✓
3 x 2"	✓	✓	✓	✓	✓	✓	✓
4 x 1/2"	✓	✓	✓	✓	✓	✓	✓
4 x 1"	✓	✓	✓	✓	✓	✓	✓
4 x 1.1/2"	✓	✓	✓	✓	✓	✓	✓
4 x 2"	✓	✓	✓	✓	✓	✓	✓
6 x 1/2"	✓	✓	✓	✓	✓	✓	✓
6 x 1"	✓	✓	✓	✓	✓	✓	✓
6 x 1.1/2"	✓	✓	✓	✓	✓	✓	✓
6 x 2"	✓	✓	✓	✓	✓	✓	✓
8 x 1/2"	✓	✓	✓	✓	✓	✓	✓
8 x 1"	✓	✓	✓	✓	✓	✓	✓
8 x 1.1/2"	✓	✓	✓	✓	✓	✓	X
8 x 2"	✓	✓	✓	✓	✓	✓	✓
10 x 1/2"	✓	✓	✓	✓	✓	✓	✓
10 x 1"	✓	✓	✓	✓	✓	✓	✓
10 x 1.1/2"	✓	✓	✓	✓	✓	✓	✓
10 x 2"	✓	✓	✓	✓	✓	✓	✓
12 x 1/2"	✓	✓	✓	✓	✓	✓	✓
12 x 1"	✓	✓	✓	✓	✓	✓	✓
12 x 1.1/2"	✓	✓	✓	✓	✓	✓	✓
12 x 2"	✓	✓	✓	✓	✓	✓	✓

ORDER REF - MOPL(DIMENSIONS)-GRADE

### MOP DRESSER

For combing the surface of a new mop or buff to produce a soft down-like surface. Also used for cleaning mops to remove surplus compound and to ensure true running. Can also be used for renovating emery bands. Supplied with a double handle.

Sold Individually



### MOP DRESSER

Length x Width	Brush Length	Rows	Wire Length	
14 x 1.3/4"	4"	5	1"	✓

ORDER REF - WOODH-MOPDRESSER







**STITCHED MOPS (STANDARD RANGE)**

**Sold Individually**

NOTES:

- 1) Each section is approximately 1/2" thick.
- 2) Close stitch – 1/4" spacing between stitching
  - Very close stitch – 3/16" between stitching
  - Open stitch – 1/2" between stitching
- 3) Loosefold mops can be stitched if required
- 4) Other sizes on request.



**IMPREGNATIONS FOR SISALS-**  
 Blue (Hard)  
 Orange (Medium)  
 OY/Tacky (Medium)  
 Green (Med/Soft)

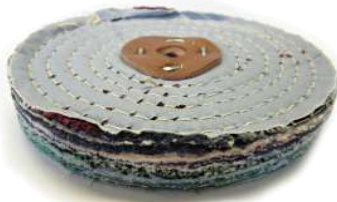

**COLOURED MOPS**

Slightly harder than white stitched mops.

COLOURED	
SIZE	
3" x 1 sec	✓
3" x 2 sec	✓
3" x 3 sec	✓
3" x 4 sec	✓
4" x 1 sec	✓
4" x 2 sec	✓
4" x 3 sec	✓
4" x 4 sec	✓
6" x 1 sec	✓
6" x 2 sec	✓
6" x 3 sec	✓
6" x 4 sec	✓
8" x 1 sec	✓
8" x 2 sec	✓
8" x 3 sec	✓
8" x 4 sec	✓
10" x 1 sec	✓
10" x 2 sec	✓
10" x 3 sec	✓
10" x 4 sec	✓
<b>ORDER REF - MOPCM</b>	



**WHITE STITCHED MOPS**

Most popular mops, for cut and colour

WHITE STITCHED	
SIZE	
3" x 1 sec	✓
3" x 2 sec	✓
3" x 3 sec	✓
3" x 4 sec	✓
4" x 1 sec	✓
4" x 2 sec	✓
4" x 3 sec	✓
4" x 4 sec	✓
6" x 1 sec	✓
6" x 2 sec	✓
6" x 3 sec	✓
6" x 4 sec	✓
8" x 1 sec	✓
8" x 2 sec	✓
8" x 3 sec	✓
8" x 4 sec	✓
10" x 1 sec	✓
10" x 2 sec	✓
10" x 3 sec	✓
10" x 4 sec	✓
12" x 1 sec	✓
12" x 2 sec	✓
12" x 3 sec	✓
12" x 4 sec	✓
<b>ORDER REF - MOPWM</b>	



**DRY SISAL MOPS**

Used first with cutting compound for flattening pre polishing

DRY SISAL	
SIZE	
3" x 1 sec	✓
3" x 2 sec	✓
3" x 3 sec	✓
3" x 4 sec	✓
4" x 1 sec	✓
4" x 2 sec	✓
4" x 3 sec	✓
4" x 4 sec	✓
6" x 1 sec	✓
6" x 2 sec	✓
6" x 3 sec	✓
6" x 4 sec	✓
8" x 1 sec	✓
8" x 2 sec	✓
8" x 3 sec	✓
8" x 4 sec	✓
10" x 1 sec	✓
10" x 2 sec	✓
10" x 3 sec	✓
10" x 4 sec	✓
12" x 1 sec	✓
12" x 2 sec	✓
12" x 3 sec	✓
12" x 4 sec	✓
<b>ORDER REF - MOPDS</b>	

**POLISHING**

## AIR FLOW MOPS

### Sold Individually

For use with a taper spindle. Airflow mops allow air circulation into the mop giving a natural cooling effect – They are designed for use on Plastic (including resin) and other temperature sensitive materials. Perfect for Plastic and Veneer polishing. The Flaps in the Cloth Wheel cool the polishing surface and reduce heat caused by friction. So there is less danger of melting the component. Each grade of mop can be supplied in different densities, i.e. hard calico, medium density, can be manufactured with more tucks of material, producing a more dense mop face. Or similarly, with less tucks than the medium density, producing a softer flexible mop face.

**5% price reduction for Soft Density (0J),  
10% price increase for Hard Density (4J)**

Each section is approximately 1/2" wide, except for Swansdown sections, which are approximately 5/8" wide. We also supply single bias sisal or single calico sections, treated or untreated – centre plates and end plates – for use on parallel spindles or automatic buffing machines.

**OJ – Soft Density  
2J – Medium Density  
4J – Hard Density**

POLISHING



AIRFLOW BUFFS			
SIZE	HARD CALICO	SOFT CALICO	SWANSDOWN
	No.1	No.2	
8" x 1 sec	✓	✓	✓
8" x 2 sec	✓	✓	✓
8" x 3 sec	✓	✓	✓
8" x 4 sec	✓	✓	✓
10" x 1 sec	✓	✓	✓
10" x 2 sec	✓	✓	✓
10" x 3 sec	✓	✓	✓
10" x 4 sec	✓	✓	✓
12" x 1 sec	✓	✓	✓
12" x 2 sec	✓	✓	✓
12" x 3 sec	✓	✓	✓
12" x 4 sec	✓	✓	✓

ORDER REF - MOPAM

## SMALL STITCHED DOLLIE MOPS

Excellent quality, tight stitched dollie mops. Ideal for use with M17 or M32 tapered mandrels.

### Sold Individually



DOLLIE MOPS			
Material	Diameter	Width	
Dry Sisal	1"	3/4"	✓
	1.1/2"	1/2"	✓
	1.1/2"	1"	✓
	2"	1/2"	✓
	2"	1"	✓
	2.1/2"	3/4"	✓
	3"	3/4"	✓
Hard Calico (WFC)	1"	1"	✓
	1.1/2"	1"	✓
Medium Calico (G) or Soft Calico (WDR)	1"	1"	✓
	1.1/2"	1/2"	✓
	1.1/2"	1"	✓
	2"	1"	✓

ORDER REF - DOL(SIZE)-(MATERIAL)

**WOOL MOPS**

Final finishing with Rouge – suggested for jewellery – silver – all large precious metal objects.  
Greasy compounds recommended for best mop adherence

**Sold Individually**



WOOL MOPS		
SIZE		
Diameter	Face Width	
125mm	25mm	✓
125mm	50mm	✓
150mm	25mm	✓
150mm	50mm	✓
190mm	63mm	✓
With Wooden 2-stage C/H for taper spindle		
ORDER REF - WOOLMOP		

**BASIL MOPS**

A final finishing mop used with rouge compositions, to leave a lustre finish, free from compound surface contamination. Especially good for finishing some precious metals, chromium plate, brass and bronze.

Sizes available are:

Diameter: 4", 6" and 8"

Thickness: 1/4", 1/2", 3/4", 1", 1.1/2"

**Sold Individually**



**POLISHING**

**CHAMOIS MOPS**

100% High quality chamois, leather washed finishing mops. Used for a final gloss finish on precious metals or on glass with rouge.



UNMOUNTED CHAMOIS MOPS		
Size		
4" dia x 16-lap (1/2")	✓	
4" dia x 32-lap (1")	✓	
6" dia x 16-lap (1/2")	✓	
6" dia x 32-lap (1")	✓	
ORDER REF - MOPCHAMOIS		

**BLACK BRISTLE END/PENCIL BRUSHES**

Used with a taper spindle on a polishing motor.

**Sold Individually**



END PENCIL BRUSHES		
Ref.	No of Knots	
BW-EPB-02	2	✓
BW-EPB-03	3	✓
BW-EPB-09	9	✓
ORDER REF - BW-EPB (No)		

**SOFT BRISTLE THUMB WHEEL**

Hand tool.

**Sold Individually**



SOFT BRISTLE THUMB WHEEL			
Ref.	Brush Dia. (mm)	Overall Length (mm)	
BW-TW-374	28	150	✓
ORDER REF - BW-TW-374			



## BLACK BRISTLE WHEELS (PLASTIC CENTRE)

Many other sizes and types available, please contact us for more details.

**Sold in Packs of 10**



PLASTIC CENTRE BRISTLE WHEELS				
Ref.	Diameter (mm)	Rows	Hardness	
P021	57	3C	Ex.Stiff	✓
BR40	67	4C	Stiff	✓
BR23	70	2C	Stiff	✓
P006	80	4C	Ex.Stiff	✓
P004	80	4S	Ex.Stiff	✓
Rows: C = Converging, S = Straight				
ORDER REF - BW-BBP-(REF)				

## BLACK BRISTLE WHEELS (WOODEN CENTRE)

Black bristle wheels with a wooden centre

**Sold Individually**



WOODEN CENTRE BRISTLE WHEELS					
Ref.	Diameter (mm)	Hub Dia. (mm)	Rows	Hardness	
BBW-60/40	60	40	4C	Stiff	✓
BBW-80/50	80	50	4C	Ex.Stiff	✓
BBW-90/50	90	50	4C	Ex.Stiff	✓
BBW-100/60	100	60	4C	Ex.Stiff	✓
Rows: C = Converging					
ORDER REF - BW-BBW(SIZE)					

POLISHING

## PENNY WHEELS

49mm metal or plastic centred penny wheels.

**Sold Individually**



PENNY WHEELS		
Ref.	Hardness	
BW-PW-Bristle	Hard	✓
BW-PW-Horsehair	Med/Hard	✓
BW-PW-Goathair	Soft	✓
(With Plastic Insert)		✓
ORDER REF - BW-PW(MATERIAL)		

## BLACK BRISTLE DOMED CUP BRUSHES

**Sold Individually**



DOMED CUP BRUSHES				
Ref.	Brush Dia. (mm)	Stock Dia. (mm)	Overall Length (mm)	
BW-BBDOME-30P	30	14	62	✓
BW-BBDOME-35P	35	14	62	✓
BW-BBDOME-40	40	18	70	✓
BW-BBDOME-50	50	25	82	✓
BW-BBDOME-60	60	32	92	✓
BW-BBDOME-70	70	32	96	✓
BW-BBDOME-80	80	35	100	✓
ORDER REF - BW-BBDOME (No)				



**MAXIGLEAM DUST CLOTHS  
EXTRA LARGE PIECES**

**200 sheet 50x70cms**

Lint free polishing cloths. Specially designed material for superior dust and dirt pick up. Made from rayon/polyester material for longer, more effective use. Soft enough for delicate finishes-sturdy enough for rugged polishing. Large absorbent cloths for maximum dust collection. Great for cleaning and polishing stainless steel, paintwork and glass. Can be washed and re-used many times. White so soils and dirt can be seen. Lager than average size pieces 50 x 70 cms.

**Sold in Boxes of 200. Large Coths, 4kg**



**MAXIGLEAM DUST CLOTHS**

1 BOX OF 200



**ORDER REF - POLISHINGCLOTHM**

**MICRO-MESH  
POLISHING CLOTH**

A very soft finishing cloth 12" square. Ideal for use with mirco mesh gloss.



**POLISHING CLOTH**

12" SQUARE



**ORDER REF - MIC-POLISHINGCLOTH**

**LINT FREE POLISHING CLOTH**

The easiest way to use the lime is by coating dry lime on a soft cloth and gently wiping the polished surface to remove residues. This lint free cloth is perfect for the job.



**LINT FREE CLOTH**

INDIVIDUAL CLOTHS



**ORDER REF - POLISHINGCLOTHS**

**3M POLISHING PAPERS**

These papers can be used wet or dry, with a fabric backing they are paper-thin. Very flexible. Ideal for jewellery although they work very well on all metals.

**Sold Per Sheet**

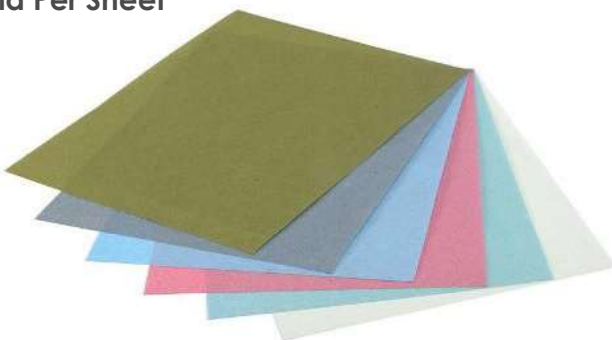

**3M POLISHING PAPER**

COLOUR	MICRON	FEPA GRIT	
<b>GREEN</b>	30 micron	400	✓
<b>GREY</b>	15 micron	600	✓
<b>BLUE</b>	9 micron	1200	✓
<b>PINK</b>	3 micron	4000	✓
<b>MINT</b>	2 micron	6000	✓
<b>PALE GREEN</b>	1 micron	8000	✓

**ORDER REF - GESS-SHEETS-(GRIT)**

Mineral: Aluminium Oxide (2, 3 & 9 micron)  
Mineral: Silicon Carbide (15 & 30 micron)  
Sheet Size: A4



## COMPOUNDS, PASTES & SPRAYS

P119-121 - PRECISION POLISHING  
P122-125 - GENERAL PURPOSE  
P126-132 - LEA, GRAINLOCK



## Compounds

It is essential to choose the right compound for the job, whilst also understanding the best speed to run them. Our compound range contains the abrasive that does all the work. We stock various grades of compound to suit a multitude of applications.

For large scale, heavy duty applications such as fabrication we stock a range of solid bar compounds as well as sateen, grainlock and plastibrade. We can offer advice on making up scurfs using these materials with our mops. Also pertinent is belt lubricant, lubar and clear laquer.

For precision engineers and mould tool makers we have a variety of pastes including diamond, algalox and simichrome. We stock Clover and Ultralap as well as other newer variations on these such as Ultrapaste and Super Alloy which are made here in the UK to very exacting standards.

For jewellers and those seeking an ultra high mirror finish we stock Menzerna compound as well as FF9 and FF11, renowned for its excellent finishing properties. You can also find more traditional rouges and tripoli.

See this section also for workshop essentials including lapping fluid, solvent cleaner and mould protection spray. We can offer lump pumice as well as powders including pumice, cerium oxide and vienna lime (this being a great final step in polishing for removing polishing residue and haze).



## DIAMOND COMPOUND

Our Diamond Compounds have been formulated using a blend of high quality green and user-friendly chemicals to produce a stable, reliable product. Our Diamond compound is produced to provide guaranteed consistent results time after time.

**Sold in 5g, 10g or 20g Syringes**

**20g Syringes offer better value for money**



5g & 10g DIAMOND COMPOUND SYRINGES							
MICRON SIZE	COLOUR	MEDIUM			HIGH		
		5gm Syringe	10gm Syringe	20gm Syringe	5gm Syringe	10gm Syringe	
(1/10)	Grey	✓	✓	✓	X	X	FINE
(1/4)	Grey	✓	✓	✓	X	X	
1	Blue	✓	✓	✓	✓	✓	
2	Pink	✓	✓	✓	✓	✓	
3	Green	✓	✓	✓	✓	✓	
6	Yellow	✓	✓	✓	✓	✓	
10	Red	✓	✓	✓	✓	✓	
16	Brown	✓	✓	✓	✓	✓	
25	Mahogany	✓	✓	✓	✓	✓	
45	Purple	✓	✓	✓	✓	✓	
60	Orange	✓	✓	✓	✓	✓	
90	White	✓	✓	✓	✓	✓	COARSE
ORDER REF - DCAS					ORDER REF - DCH		



Available in 2 concentrations:

**MEDIUM:** Low cost, high quality diamond compound. Oil & water miscible.

**HIGH:** Highly graded diamond giving a more even surface finish. Oil & water miscible.

COMPOUNDS

## LIQUID DIAMOND COMPOUND

Use with a 250ml spray bottle which we can supply for £1.50 each.

\*Shake vigorously to combine especially before using.

**Sold in 100g Bottle**



## LAPPING FLUID

Improves diamond cutting by adding necessary lubrication and prevents lap loading and drying out.

**Sold in 5L, 1L or 250ml (Refillable) Pump Spray**



DIAMOND SPRAY	
MICRON SIZES	
1/10 - 1/4 - 1/2	✓
1 - 3 - 6 - 10	✓
16 - 25 - 45	✓
ORDER REF - AD(MICRON SIZE)	

LAPPING FLUID	
5 Litre Container	✓
1 Litre Container	✓
250ml Pump Spray (refillable)	✓
ORDER REF - LF	

## SOLVENT SPRAY CLEANER

General purpose – Non-chlorinated 'Moleroda' Solvent Cleaner combines the strength of a powerful degreasing agent with the benefits of aerosol application. Contaminates such as oil, grease, wax etc. are readily removed with minimum solvent wastage.

### BENEFITS:

Strong solvent action, non-conductive, fast evaporation.

**Sold in 400ml Can or 5 Litre Drum**



**BEST SELLER**

SOLVENT CLEANER	
QUANTITY	
400ml can:	✓
5 ltr drum:	✓
ORDER REF - LF	

## ANTI-CORROSIVE MOULD PROTECTION

GREEN (with dye) or CLEAR

Grease and Silicon Free

Protection against rust and moisture attack.

It is suitable for the plastics and rubber industry for long or short term storage of mould tools. On general moulding, Mould Protection Spray will be removed during the first few shots. For non-moulding or quick removal, use 'Moleroda' Solvent Cleaner.

**Sold in 400ml Can**



MOULD PROTECTION SPRAY	
QUANTITY	
400ml can:	✓
ORDER REF - LFMOULDPROTECT	

COMPOUNDS

## MOLERODA SUPER ALLOY/CHROME POLISH

For non ferrous metals such as Aluminium, Brass etc. Animal Tissue Free. Much cheaper alternative to Simichrome.

**Sold in 250ml Tubs**



SUPER CHROME/ SUPER ALLOY	
QUANTITY	
250 ml Tub	✓
ORDER REF - COMPSUPER	

**We would recommend trying our new 'Moleroda Super Chrome Polish'. A much cheaper alternative and UK made.**

## CLOVER COMPOUND

Recommended for lapping and polishing of hardened steels. Made from accurately graded abrasive grain suspended in petroleum grease mix carrier. Supplied in 1 lb. Cans.

**Sold in (approx) 450g Can**



CLOVER COMPOUND				
GRADE	GRIT	ABRASIVE	RECOMMENDED USE	
CCG	80	Silicon Carbide	Very Coarse - fastest metal removal	✓
CCB	240		Medium- good metal removal	✓
CC2A	400		Fine - fine polishing & lapping	✓
CC4A	600		Very Fine - fine polishing & lapping	✓
CC5A	800		Very Very Fine- for optical polishing	✓
CC7A	1200		Ultrafine- high precision lapping & polishing	✓
ORDER REF - CLOVER				



**ULRAPASTE**

Ultra Lapping Paste is an excellent quality abrasive paste compound made here in the UK. Polishing pastes are ideal for lapping and polishing hardened steels, chrome, soft non-ferrous metals and hard alloys. Comparable to both Ultralap and Clover Compound. However being made in the UK it is quicker to supply and is a very attractive price. Available 500g tubs.



**BEST SELLER**

ULRAPASTE COMPOUND			
GRIT	ABRASIVE	RECOMMENDED USE	
120, 240	Silicon Carbide	Coarse, fast stock removal. For roughing tools, dies, moulds.	✓
320, 400		Preparatory finish for tool steels and hard alloys.	✓
500, 600		Scratch-free, dull finish on all hard metals.	✓
800		Semi-finish on tool, chrome and stainless steels.	✓
1000		Fast, high lustre on tool, chrome and nitrided steels.	✓
1200		For high polish precision parts.	✓
<b>ORDER REF - ULRAPASTE</b>			

**ULTRALAP**

A premium quality, ready-mix abrasive compound for finishing and polishing all types of steels, chrome, soft non-ferrous metals and hard alloys. Supplied in Tubs.

**Sold in (approx) 450g Tub**



**COMPOUNDS**

ULTRALAP COMPOUND				
GRADE	GRIT	HARDNESS/ABRASIVE	RECOMMENDED USE	
ULB400	400	Soft	Semi-finish for soft steel and non-ferrous metals.	✓
ULC120	120	Hard Silicon Carbide	Coarse, fast stock removal. For roughing tools, dies, moulds.	✓
ULC200	220			
ULC300	320			
ULC400	400	Hard Silicon Carbide	Preparatory finish for tool steels and hard alloys.	✓
ULC600	600	Hard Silicon Carbide	Scratch-free, dull finish on all hard metals.	✓
ULH500	500	Hard, Sharp Aluminium Oxide	Semi-finish on tool, chrome and stainless steels.	✓
ULH900	900	Hard, Sharp Aluminium Oxide	Fast, high lustre on tool, chrome and nitrided steels.	✓
ULH3000	3000	Hard, Sharp Aluminium Oxide	For high polish precision parts. Less than 1 micron finish.	✓ (2 oz. Tube)
ULLA	Levigated Alumina	Soft, Fine Alumina	Super fine, high polish for precision parts.	✓
<b>ORDER REF - ULTRALAP</b>				

## ANTOX 71E-PICKLING PASTE

Free from hydrochloric acid and chlorides. Economical in use – Simple applications

**APPLICATION:** To remove local oxide scale formations from welding seams and heat affected areas of stainless steel fabrications.

**USE:** Approximately 2 kg of 71E is sufficient to treat 80-150 metres of weld seam 5cm wide.

**METHOD:** The creamy consistency enables simple application with a metal-free brush. Reaction time is from 15-60 minutes, dependent on type and amount of scale.

**NEUTRALISING:** Wash off thoroughly with water, using a stiff brush.

**DESCRIPTION:** An opaque paste containing hydrofluoric and nitric acids.

Sold in 2KG Containers



ANTOX	
QUANTITY	
2kg Container	✓
ORDER REF - METINOX	

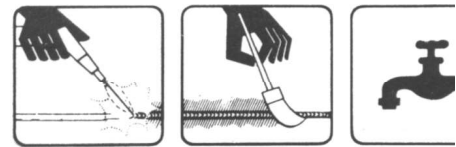

## ARECAL CLEAR LACQUER

Stainless steel, aluminium, chrome, and paint. Clear lacquer for all surfaces. Seals and protects surfaces. Elasticated. CFC Free.

Sold in 400ml Cans



ARECAL CLEAR LACQUER	
QUANTITY	
Clear Lacquer 400ml	✓
ORDER REF - RECASPRAY-CLEAR	

## LUBAR/TALLOW (BOBBING GREASE)

Medium/hard grease bar. Lubricant for use with Plastibrade, set-up wheels etc. Plus hot metal spinning.

Sold Per Bar (32 Cups Per Box)



LUBAR		
Grade	Average	✓
	Cup Weight	
Kybo	0.5kg	✓
Lubar	0.5kg	✓
ORDER REF - COMPLUBAR		

## KYBO

Softer bar than lubar, very similar products in terms of process. similar melting point as lubar.

Sold Per Bar (32 Cups Per Box)



**PUMICE POWDER**

A powder which is mixed with water to form a paste for scratch removal on glass, normally before cerium oxide.

**Sold Per Kg**



PUMICE POWDER	
All Grades	
per kg	✓
per 22.68 kg Bag	✓
ORDER REF - PUMICEPOWDER	

**LUMP PUMICE**

Used for cleaning polishing buffs of old components. Degreasing satene mops of bobbing grease. Dressing satene mops and felt bobs.

**Sold Per Kg**



LUMP PUMICE	
Grade: BRMP	
per kg	✓
ORDER REF - PUMICELUMP	

**CERIUM OXIDE**

A refined peach powder, with no sharp edges, fast acting scratch removal. An abrasive for polishing of flat glass and crystal. Mix with water into a paste – use with felt, chamois and basil mops.

**Sold Per Kg**



CERIUM OXIDE	
per kg	✓
ORDER REF - COMPCERIUMOX	

COMPOUNDS

**VIENNA LIME**

Used for removing polishing compound residues. To do so, simply coat a soft cloth in dry lime and gently wipe over the polished item. Can also be used to bring up extra colour on Stainless Steel. Sprinkle lime on the steel and polish with a Swansdown mop. Do not use vienna lime wet.

**Sold Per Kg**



VIENNA LIME			
Grade:	up to	25 kg	50 kg
Fine	10 kg		
per kg	✓	✓	✓
ORDER REF - LIME			
LINT FREE CLOTH			
Individually	✓		
ORDER REF - POLISHINGCLOTHS			

## ALGALOX ALUMINIUM POLISHING PASTE

A specialist white polishing paste for non-ferrous metals (especially good on aluminium). This paste is very evenly graded in aluminium oxide making it a perfect polishing paste, giving a very clean finish.

**Sold in 20g Syringe**



ALGALOX PASTE	
GRADE	20g Syringe
1 Micron	✓
3 Micron	✓
6 Micron	✓
9 Micron	✓
15 Micron	✓
30 Micron	✓

**ORDER REF - ALGALOX-(MICRON SIZE)**

## MICRO-GLOSS LIQUID ABRASIVE

A polish and cleaner for Polycarbonate, Gelcoat, Vinyl Coatings, Plastics etc. Water based formulation that contains an abrasive crystal in micron gradings. Use after 12000 Micro-Mesh as a final step to add lustre. Micro-gloss 5 will remove scratches up to 9 micron in depth, this should be followed by Micro-gloss 1. Dampen surfaces prior to application. Can be used by hand or with a lambswool Tuf-Buf.



MICRO-GLOSS LIQUID ABRASIVE		
Bottle Size	Micron Size	
	1 Micron	5 Micron
1 Oz	✓	X
2 Oz	✓	✓
4 Oz	✓	✓
8 Oz	✓	✓

**ORDER REF - MICROMESHGLOSS**

COMPOUNDS

## FINAL FINISH CONDITIONER

Vinyl conditioner combining high quality Carnuba wax and soft cutting liquid abrasive. Keeps vinyl supple and conditioned. Use after the Micro-gloss stages.



FINAL FINISH CONDITIONER	
Bottle Size	
2 Oz	✓
4 Oz	✓
8 Oz	✓
1 Gallon	✓

**ORDER REF - MICROMESHFINALFINISH**

## MICRO-FINISH

A polish that brightens, use as a final finish! Removes any residual haze.



MICRO-FINISH POLISH	
Bottle Size	
2 Oz	✓
4 Oz	✓
8 Oz	✓

**ORDER REF - MICROMESH-MICROFINISH**

## SIMICHROME

Excellent polish for removing tarnish from moulds. Brings out the high lustre of metals, removing the 'haze' often left after final diamond polish.

Can be applied with felt bobs, buffing wheels or by hand using a soft cloth.



SIMICHROME	
QUANTITY	
125gm Tube:	✓

**ORDER REF - SIMICHROME**



## TAP MAGIC

Professional quality cutting fluid for Aluminium. Apply as needed to maintain lubrication between cutting tools and a work piece. Dramatically improves surface finish and increases tool life. For drilling, milling, reaming, threading, boring, turning, engraving, broaching, sawing, tapping etc..



TAPMAGIC	
Bottle Size	
16 Oz	✓
ORDER REF - MIC-TAPMAGIC	

## WINBRIGHT

Professional strength plastic cleaner with Micro-brightener. Leaves surfaces clear and clean - optical clarity improves with extended use. Leaves no residue or build-up. Developed for plastics including, aircraft windows, motorcycle windscreens, boats (including Gelcoat) and Vinyl surfaces. Rinse surface with water before use. Removes surface dirt, wax, stains and finger prints.



WINBRIGHT SPRAY	
Bottle Size	
8 Oz	✓
ORDER REF - MIC-WINBRIGHT	

## BUG BLASTER

Cleaner for windows and wings. Dissolves and removes bug residue without scrubbing. Safe on plexiglass, acrylic, clear coat, polyurethane paints, polished aluminium etc. Ideal for aircraft, motorbikes, classic cars etc.



BUG BLASTER SPRAY	
Bottle Size	
8 Oz	✓
32 Oz	✓
ORDER REF - MIC-BUGBLASTER	

## ANTI-STATIC CREAM

A compound that protects surfaces and removes static charges that cause dirt and dust to collect on newly polished surfaces. Particularly useful with plastics.



ANTI-STATIC CREAM	
Bottle Size	
2 Oz	✓
8 Oz	✓
1 Gallon	✓
ORDER REF - MICROMESH-ANTISTATIC	

## MEDIMAX BOVINE & ANIMAL TISSUE FREE COMPOUNDS

Widely used in the orthopedic implant, surgical tool and pharmaceutical fabrication industries. Also used in Food processing, veterinary, dairy and brewing industries to conform with strict guidelines and EU directives.



Other compounds are also available including finishing grease.

MEDIMAX RANGE			
Stage	Recommended Compound	Description	
1st Stage	<b>Plastibrade Red (120 grit) 9KG</b>	Fast drying liquid abrasive for deburring & satin finishing. Used on mops or felt bobs.	✓
Cutting	<b>Abracut</b>	Hard aggressive polish, medium greasy.	✓
Polishing	<b>Medimax White</b>	Finishing bar with good cut for Stainless	✓
	<b>Medimax Pink</b>	Finishing compound for Stainless	✓
	<b>Medimax Green</b>	High gloss, soft auto compound	✓
<b>ORDER REF - COMP(PLASTIBRADE/ABRACUT/MEDIMAX)</b>			

## MINI LEA POLISHING COMPOUNDS

4 x 1" Bars

Smaller size compound bars from LEA, Ideal for hobbyists, sampling compound etc  
Sold Per Bar



4 X 1" BARS



ORDER REF - COMP41

### NON-FERROUS METALS

Blue and Brown bars for metals such as aluminium and brass  
Brown- 1st stage Cutting & flattening bar  
Blue- for the perfect mirror finish



### PLASTICS, VENEERS & SYNTHETICS

Buff and Brown bars for materials such as Resin and plastics  
Brown-1st stage Cutting & flattening bar  
Buff- for the perfect final finish



### FERROUS METALS

Pink & Black bars for metals such as stainless steel  
Black- 1st stage Cutting & flattening bar  
Pink- for the perfect mirror finish



### PRECIOUS METALS



Brown & Red bars for metals such as gold and silver  
Brown- 1st stage Cutting & flattening bar  
Rouge- for the perfect mirror finish



\*Mini Compounds are not included in the Medimax range and may contain animal tissue.

## LEA COMPOUNDS FOR FERROUS METAL

Such as Steel, Stainless Steel etc...

FERROUS METAL POLISHING COMPOUND - 8 X 2 X 2"				
PROCESS	SUGGESTED MOPS	RECOMMENDED COMPOUNDS	COMPOUND INFORMATION	
<b>1st STAGE</b> Removing Deep Marks & Lines	Felt wheel or WFC mop (White Stitch Mops)	<b>Grainlock and Aloxite (Making a Scurf)</b> See Page 131	 	
<b>2nd STAGE</b> Producing a Saftene finish & removing light lines	Felt wheel or WFC mop (White Stitch Mops)	<b>Lea Satene Compounds</b> See Page 130		
<b>3rd STAGE</b> Cut and Flattening - Removing of lines and marks	Impregnated Sisals	<b>Abracut</b>	Grey - Very Coarse Alumina, The highest cut compound for Ferrous metals	✓
		<b>Senior (4040)</b>	Grey - Greasier and coarser than 2464. High cutting	✓
		<b>3050/ Ferrocut</b>	Grey - Matt finish. Slightly Greasy.	✓
		<b>Titan</b>	Grey - Good surface levelling qualities on mild steel prior to nickel or chrome plating.	✓
<b>4th STAGE</b> Cut and Colour - Leaving a reasonable finish	Impregnated Sisals and Dry Sisals	<b>2755/ Brillmax</b>	Yellow - Good General purpose	✓
		<b>2000D/ Hero</b>	Green - A one operation bar, cut and high colour. Less Greasy than other bars.	✓
		<b>2464/ Abramax</b>	Grey - An all rounder on Ferrous metals	✓
		<b>Midas</b>	Yellow - Good cut and colour and leaves a good clean finish.	✓
<b>5th STAGE</b> Finishing - Polish to a mirror finish	White Stitched Mops All Loose Fold Mops	<b>FF9/ Mirromax</b>	White - The ultimate finishing bar. Exceptional high colour & depth, extra fine finish.	✓
		<b>309BX Chromax/Jupiter</b>	White - Is slightly less greasy and good finish clarity.	✓
		<b>Sunblue</b>	Blue - Fine scratch finish on ferrous and non-ferrous metals. Blue finish grade.	✓
		<b>2000D/ Hero</b>	Green - A one operation bar, cut and high colour. Less Greasy than other bars.	✓

ORDER REF - COMP(NAME) e.g COMP2000D

COMPOUNDS

## MENZERNA COMPOUNDS

Menzerna is a high quality, extremely clean compound manufactured in Europe. It is very popular across all polishing industries.



Full bars are 1.2kg  
Half bars are 600g

MENZERNA COMPOUNDS			
PROCESS	TYPE	COMPOUND INFORMATION	
<b>Cutting</b>	<b>456G</b>	Grey - 600g half bar - greasy, pre-polishing compound, ideal for harder metals such as Platinum and Steel	Half Bar ✓
		Yellow - a high class scratch free mirror finish, used as a final finish on all metals, platics and lacquers. Gloss 9/10 Abrasive 2/10	Full Bar ✓ Half Bar ✓
<b>Super Finishing</b>	<b>M5</b>	White - Slightly better, drier finish than P175. For a gloss finish on all metals including Titanium, Platinum and Palladium. Gloss 10/10 Abrasive 1/10	Full Bar ✓ Half Bar ✓

ORDER REF - COMPMENZ-(TYPE)

# NON FERROUS METAL & SYNTHETIC/PLASTIC POLISHING



## LEA COMPOUNDS FOR NON-FERROUS METAL

Such as Aluminium, Brass, Copper, Bronze etc..



NON - FERROUS METAL POLISHING COMPOUND - 8 X 2 X 2"				
PROCESS	SUGGESTED MOPS	RECOMMENDED COMPOUNDS	COMPOUND INFORMATION	
<b>Cut (Pre-finish) Removing of lines and marks</b>	Impregnated Sisals Dry Sisals White Stitched Felts	<b>Apollo</b>	Brown - Very good cut and colour (especially on Brass). Fine-lined Finish.	✓
		<b>2468</b>	Brown Very dry, Very good on Aluminium. Good cut & colour with a clean finish.	✓
		<b>2640</b>	Brown - Greasier than 2630, good cut on non-ferrous, especially brass.	✓
<b>Finishing - Polish to a mirror finish</b>	White Stitched Loosefold Felts	<b>FF9/ Mirrormax</b>	White - The ultimate finishing bar. Exceptional high colour & depth, extra fine finish.	✓
		<b>309BX/ Chromax/Jupiter</b>	White - Is slightly less greasy and good finish clarity.	✓
		<b>Sunblue</b>	Blue - Fine scratch finish on ferrous and non-ferrous metals. Blue finish grade.	✓
		<b>2000D/Hero</b>	Green - A one operation bar, cut and high colour. Less Greasy than other bars.	✓

ORDER REF - COMP(NAME) e.g COMPAPOLLO

COMPOUNDS

## COMPOUNDS FOR PLASTICS, VENEERS & SYNTHETIC MATERIALS

Including Resins and Acrylic.

Polishing synthetic surfaces, require much lower buff peripheral speeds. A polishing spindle of 1440 rpm, fitted with 12" diameter Airflow Buffs should cause no surface overheating problems. Another important factor to consider – the mop face must be kept scrupulously clean – dry compound or tails of calico will cause marks. If using soft calico Loosefold Mops, use a smaller diameter than the Airflow normally used. An Airflow produces a cooler polishing surface than a Loosefold Mop.



PLASTIC POLISHING COMPOUND - 8 X 2 X 2"				
PROCESS	SUGGESTED MOPS	RECOMMENDED COMPOUNDS	COMPOUND INFORMATION	
<b>Cut (Pre-finish) - Removing of lines and marks</b>	Hard Calico	<b>Matador</b>	Grey - Produces scouring action. Good for removal of machine marks or where bandsawing has taken place. Should not be used on already good surfaces.	✓
		<b>Apollo</b>	Brown - Used for preparing for polishing.	✓
		<b>2640</b>	Brown - Greasier than 2630, used for surface preparation before polishing.	✓
<b>Finishing</b>	Soft Calico Airflow Swansdown	<b>Wax 16</b>	Buff - Fine Cutting and Finishing wax bar. Well lubricated and clean finish.	✓
		<b>Wax 25</b>	Buff - Finishing bar for plastics components, polyesters, lacquers and laminates. Fine & soft abrasive.	✓

ORDER REF - COMP(NAME) e.g COMPWAX16



PRECIOUS METAL POLISHING COMPOUND				
PROCESS	RECOMMENDED COMPOUNDS	COMPOUND INFORMATION	SUGGESTED MOPS	
Cut (Pre-finish) - Removing of lines and marks	Apollo (Tripoli)	Brown - For surface preparation before polishing on Gold, Silver and other non-ferrous metals	Felts White Stitched Loosefold	✓
	Tripmax (4x1")	Mini version of Apollo - Brown		✓
	Menzerna 456G	600g half bar- Grey and Greasy. Pre-polishing compound, ideal for harder metals such as Platinum		Half Bar ✓
Finishing - Polish to a mirror finish	FF9/ Mirrormax	White - The ultimate finishing bar. Exceptional high colour & depth, extra fine finish. Works well on Platinum.	Felts White Stitched Loosefold	✓
	Rouge compounds	A selection of Rouge Compounds		✓
	Dialux	Range of 5 Types		✓
	Rouge STARMAX	4" x1" bar. Excellent general purpose on precious metals		✓
Super Finishing - Use once a good finish is achieved The cleanest compounds on the Market	Menzerna P175	Yellow- a high class scratch free mirror finish, used as a final finish on all metals, plastics and lacquers. Gloss 9/10 Abrasive 2/10	WDR Swansdown Reflex	Full Bar ✓ Small Bar ✓
	Menzerna M5	White- Slightly better, drier finish than P175. For a gloss finish on all metals including Titanium, Platinum and Palladium. Gloss 10/10 Abrasive 1/10		Full Bar ✓ Small Bar ✓

ORDER REF - COMP(NAME) e.g COMPF9

## ROUGE COMPOUND

Particularly good for Gold & Silver  
Sold Per Bar



ROUGE COMPOUND				
PRODUCT	FINISH DEFINITION	SUGGESTED MOPS	Bar Weight	
REDFIN	Soft, clean finishing rouge for final polishing of precious metals. Excellent colour.	G, Reflex & Swansdown Loosefolds	424 gm	✓
SF ROUGE	Final finish bar for precious metals and brass components. Good depth of colour.		270 gm	✓
AA ROUGE	Dry ultrafine rouge for gold and silver finishing.		400 gm	✓
RADIO ROUGE	Final colouring of non-ferrous materials, for extra brilliance. Ultrafine abrasive for finishing precious metals.		300 gm	✓
RED ADMIRAL	Semi-dry. Superfine. Best on silver plate and solid silver products.		120 gm	✓

ORDER REF - COMP(NAME) e.g COMPREFIN

## DIALUX COMPOUND

A popular, premium compound made in Europe. Different coloured Rouge bars to suit a full spectrum of metals.

Sold Per Bar



DIALUX COMPOUND		
PRODUCT	DESCRIPTION	
Dialux Bleu (Blue)	Super finishing compound for all metals, especially chrome alloys	✓
Dialux Vert (Green)	Super finishing compound for hard metals (chrome, platinum)	✓
Dialux Rouge (Red)	Super finishing compound for gold and other precious metals	✓
Dialux Black (Black)	Very good for platinum and for palladium. Good on hard metals	✓
Dialux White (White)	Super finishing compound for all metals, especially silver	✓
Dialux Gris (Grey)	Gets deep scratches out. Good on hard metals. Slightly greasy.	

ORDER REF - COMPDIALUX(COLOUR)

## LEA SATENE COMPOUND

Greaseless abrasive bar compound.

**Sold Per Tube**

**20 Tubes per Carton**



LEA SATENE COMPOUND		
Grade	Abrasive	
A80	80g A/Oxide	✓
A120	120g A/Oxide	✓
A150	150g A/Oxide	✓
A180	180g A/Oxide	✓
A220	220g A/Oxide	✓
A240	240g A/Oxide	✓
A320	320g A/Oxide	✓
S120	120g S/Carbide	✓
AS200	200g A/Oxide & S/Carbide	✓
No.3	Glue Bond	✓
<b>SOLD PER TUBE - 20 TUBES PER CARTON</b>		
<b>ORDER REF - COMPA...</b>		

## INSTRUCTIONS FOR MAKING A SATENE & NO.3 ADHESIVE

### No.3 – Description

Glue-based adhesive sizing for improving adhesion of Lea greaseless compound.

### Uses

When objects being buffed have sharp edged, projections or recessed areas, a raking action against the face of the mop may occur and the Lea Compound head wears away prematurely. This raking action can be reduced with the use of AdLEAsive on the mop prior to heading with Lea Compound. Many polishing operations formerly done with set-up wheels and which take a great deal of time to prepare, can be handled more speedily and economically with AdLEAsive and Lea Compound. Heavy abrasive heads are easily applied to the mop and are easy to renew with Lea Compound.

### Method of Application

- Peel away about 1/2" of the plastic container. Never peel away the complete container.
- Where resiliency of a Lea Compound headed wheel must be retained, AdLEAsive is applied in the same manner as Lea Compound, on a loose muslin or sewn mop. Where harder polishing wheels are to be used, it is advisable to apply AdLEAsive in heavier coatings with the 'start and stop' technique. Such heavier coatings provide a good base for the subsequent more rigid heads of Lea Compound.
- 'Stop and start' method of applying a heavy coating of AdLEAsive. Bring bar of AdLEAsive against the clean surface of the revolving mop and as pressure is applied, the power is switched off. This allows a heavy coating of AdLEAsive to melt and flow onto the surface of the wheel. The polishing spindle is then switched on and off to start drying, with the buff rotating at less than full speed until the sizing coat is no longer sticky to the touch. The total drying time should be two minutes. Repeat the procedure if necessary.
- If resiliency of mopping is required and a light coating of AdLEAsive is applied as in (B), Lea Compound is applied by frictional transfer in the normal manner.
- If a rigid head of Lea Compound is required over the heavy coating of AdLEAsive as applied in (C), the same 'start and stop' method should be used. This procedure makes it possible to build up Lea Compound heads as thick as 3/16", although it is necessary to make a second application of Lea Compound for the thicker coatings, making sure that the 'start and stop' method be followed closely. This procedure of producing and reproducing polishing wheels with Lea Compound and AdLEAsive permits them to be left on the lathe and ready for use in less than 10 minutes total elapsed time.

### Using Proper Type & Size Buff

Generally speaking, the following rules should apply:

Flexible finishing and deburring – soft stitched mops. Satin finishing and mopping – loosefold, usually unstitched mops or string wheels. Heavy polishing – hard stitched mops or felt wheels, which may be pre-heated with AdLEAsive to give improved adhesion of Lea Compound.

Diameters of some mops should be selected to give peripheral speed of 1500 to 6000 surface feet per minute, depending upon the results desired.

### Applying Lea Compound to the Mops:

Press bar against the rotating buff. Switch off the motor and press harder. This procedure may be repeated a number of times to build up a good 'head'. Never run the 'head' of Lea Compound down to the nap of the mop. As the 'cut' decreases, re-head by gently pressing the bar on the wheel. Whilst working, the mop will be warm and the new head will dry quickly.

NOTE: For maximum head retention, "oven" drying is recommended.

**GRAINLOCK COLD CEMENT**

**Uses:**

**GRAINLOCK HD** – The most widely used cement for all grain sizes up to 240 grit – heavy duty.

**GRAINLOCK CS** – general purpose cement for use with grain sizes 180-320 or finer. Final drying conditions (recommended minimum) are 16 hours at 125°F.

**GRAINLOCK GB** – recommended for the most severe service, essentially for grain sizes 60-150. Final drying conditions (recommended minimum) are 16-20 hours at 150-160°F.

GRAINLOCK COLD CEMENT		
GRADES	HD	CS
25 kg drum	✓	✓
6.5 kg tub	✓	✓
GRADE	GB	
6.5 kg tub	✓	
ORDER REF - GRAINLOCK		

**Method of Application - MAKING A SCURF**  
**Heading-up Buffs**

- 1) Clean face of wheel, thoroughly removing all traces of grease, glue or foreign matter.
- 2) For best results, a sizing coat is recommended. Brush the sizing into the face of the wheel until it is saturated. Air dry for 1/2 hour then dry at 150°F for one hour. Allow wheel to cool to room temperature before setting up. Sizing penetrates into the face of the wheel, creating a stronger bond for the heads of cement and abrasive which will follow.
- 3) Apply first head of cold cement straight from the container by brushing thoroughly into the face of the wheel. Roll wheel in the abrasive grain. When it has dried sufficiently, add second coat of grain and permit wheel to air dry for 1/2 hour before placing it in a drier for the recommended period.
- 4) Before placing the wheel on the spindle, break up the surface by gently tapping the face of the wheel with a round bar. A well-broken face will aid in cutting.
- 5) NEVER let set-up wheels wear down to the nap, leave a little cushion head when ready for re-setting. This saves time and reduces the amount required for a new sizing coat, as well as leaving the wheel more firm and durable.
- 6) Wheels should be thoroughly dried after setting-up. Drying can be carried out in air for at least 24 hours, or in heated driers. In all cases, free circulation of air is required to give uniform temperature and optimum conditions.



**COMPOUNDS**

**ALOXITE GRIT**

Aloxite grit available in a range of grits. One option for blasting or used with Grainlock cement to make a scurf.

**Sold Per Kg**

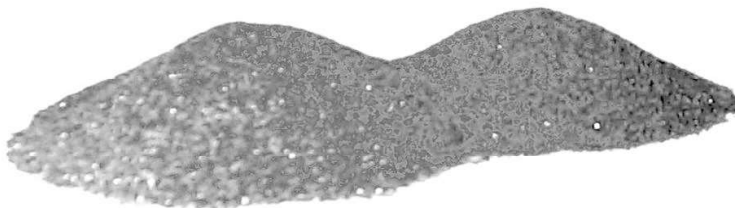

ALOXITE GRIT	
Weight	
under 5 kg	✓
5 ~ 9 kg	✓
10 ~ 24 kg	✓
<b>Grits available:</b>	
<b>60,90,120,180,240,320</b>	
ORDER REF - ALOXITE	

## PLASTIBRADE

Flexible, fast-drying, liquid abrasive.

Uses: Deburring, polishing and satin finishing. Available in a wide range of grain sizes, usually used on bobs and set-up wheels for scurfing operations.

### Method of Application:

Lea Plastibrades are non-flammable, fast drying liquid abrasive compositions for flexible polishing, deburring, etc. on all metals and a wide range of plastics and wood. Plastibrade Red has considerably more flexibility than the standard Plastibrade Grey and should be used for all fine satin finishing or where a low and even micro finish is required.

Lea Plastibrade Grey is available with aluminium oxide abrasives ranging in grit sizes from 60 to 320. Lea Plastibrade Red is available in aluminium oxide and fine powders in grit sizes 120 to 400.

The suggested directions for applying Plastibrade Grey given below need not be taken as hard and fast rules. A number of users have found that modifications to these suggestions render the product more suitable for their particular application and users are encouraged to experiment for maximum efficiency.

Throughout these directions, where sizing is referred to, Plastiglue Sizing should be used with Plastibrade Grey and Plastiglue 9222 with Plastibrade Red. Where however, the maximum flexibility of head is required with fine grit sizes of Plastibrade, it is advisable not to size at all.



PLASTIBRADE		
PACK SIZE	Plastibrade Grey	Plastibrade Grey
	60-220 grit	240 grit & finer
25 kg drum	✓	✓
9 kg tub	✓	✓
PACK SIZE	Plastibrade Red	Plastibrade Red
	120-220 grit	240-320 grit
25 kg drum	✓	✓
9 kg tub	✓	✓

**ORDER REF - PLASTIBRADE**

### Suggested Directions for use of Plastibrade Grey/Red:

A: Setting up of polishing wheels or rolls by brushing.

- 1) If other compositions have been used on polishing wheels or rolls, clean off face thoroughly. New wheels will not require any special preparation other than normal 'raking out' with surform file or hacksaw blade.
- 2) Size wheel or roll with Plastiglue Sizing by brushing it thoroughly until the face is completely saturated. Air dry for 1/2 hour then dry at 150°F for at least 1 hour or until sizing coat is thoroughly dried. Heads may be completely air dried, but will require 6-8 hours.
- 3) Apply a thin coating of Plastibrade by brushing it thoroughly into the face of the wheel. Plastibrade should be used as it comes from the container. If it is too thick it may be thinned with Plastiglue Sizing to proper consistency.
- 4) Cutting head of Plastibrade may be built up by applying a second and third coat in the same manner as step (3). Sufficient drying time should be allowed between applications.
- 5) Permit wheel or roll to air dry for 30 minutes, and then i) force dry for 6-8 hours at 150°F or ii) air dry for a further 24 hours. Air drying may be preferred as this retains greater flexibility in the head.

N.B. Brushes – it is important that the right type of brush is selected. A first quality brush with the bristles set in vulcanite is best. The conventional type of glue brush is unsuitable as the bristles are too coarse and do not allow the operator to brush on the essential smooth head. On larger wheels and rolls, a paint roller will be found to be more convenient. The paint roller should have a cover of man-made fabric, NOT natural wool. Brushes and rollers should be cleaned immediately after use, in warm water.

B: Setting-up of polishing wheels or rolls by spraying.

The finer grades of Plastibrade may be applied to a new or thoroughly cleaned buff by spraying. Buffing wheels or rolls may be headed up originally and then re-headed on the machine in actual production. Suitably designed spray guns and accessory equipment should be selected and used to apply Plastibrade coating consistently and uniformly. Since a number of variables must be considered in the selection of spray equipment and grade of product, it is advisable to call in a technical representative to discuss spray application.





TOOLS & EQUIPMENT

- P134-138 - MICROMOTORS
- P139 - ULTRASONIC
- P140-146 - ROTARY TOOLS
- P146-150 - GRINDERS
- P152-153 - MANDRELS
- P151 - LINISHERS
- P165-168 - WELDING



Included in the catalogue is a wide range of tooling and equipment that over the years we have learned are the best in the business.

Whether polishing or grinding. By air or electric. Whether large or small components or large or small quantities we have a strong range of tooling and equipment to support your needs.

From the best selling **Eneska 600** micromotor, to a great range of industrial air grinders.



TOOLS &  
EQUIPMENT



# ENESKA 600

- **Fast speeds** (50,000 RPM) and excellent torque 8,9 N/cm
- **30% more power** than the 4-1, 280 Watts
- **Less vibration**, 0.01mm deviation from axis
- **Runs quietly**
- **Integrated voltage converter - 240 - 110v**
- **More clamping force**, essential at higher speeds
- **Compatible with URAWA, Eneska and other micromotor systems**
- **Modular System** full range of hand pieces, angled heads and Diprofil filing heads.



Order Ref - 0011201

**Eneska 600 can be used with existing Eneska 4-1 or 3-2 motors and handpieces, with adaptors.**  
They will, however, still be restricted to their recommended RPM.

# JEM 50 KIT - NEW GENERATION



**ENESKA 600  
CONTROL BOX**

**JEM 50 KIT**  
ORDER REF - ENESKA-0011286



**JIR 40R**



**JEM 50 R**

- 1 - ENESKAmicro 600 control box
  - 1 - JEM 50 motor with 50,000 rpm incl. motor cable
  - 1 - Straight Handpiece – JIR40 Rapid Chuck Handpiece incl. 3mm collet
- Modular system with multiple interchangeable heads. Angled, filling, belt sander etc.  
High torque – variable speed – low noise and low vibration  
Safety features – automatic cut out.

TOOLS & EQUIPMENT

All handpieces and motors compatible with the ENESKA 600 control box. All motors include motor cable.

## Motors



**JEM 20R**

ORDER REF - ENESKA-010003



**JEM 50R**

ORDER REF - ENESKA-0100020



**JEM 50C**

ORDER REF - ENESKA-0100001

## Handpieces



**JERA 90 20R**

ORDER REF - ENESKA-0100004



**JEHG 20R**

ORDER REF - ENESKA-0100007



**JEAH 60 20R**

ORDER REF - ENESKA-0100011

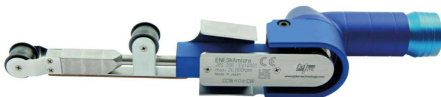

**JBS 20R**

ORDER REF - ENESKA-0100008



**JMH 20R**

ORDER REF - ENESKA-0100009



**REDUCTION GEAR - JERG2**

ORDER REF - ENESKA-0100010



**JIR 40R**

ORDER REF - ENESKA-0100020

JIR 40R Can run up to 50,000 RPM



**JBMXLH 40R**

ORDER REF - ENESKA-0100006L

**TOOLS & EQUIPMENT**

20R range suitable for higher power by using the reduction gear. (Pictured above)



Older handpieces such as the 3-1 & 4-1 can connect to the new JEM 50 motors with the right adaptors.

Please call to discuss which adaptor will be suitable for your set up.

## MAXFORCE B150

The Maxforce B150 Micro motor system is for drilling, grinding, sanding, polishing and de-burring in jewellery and industrial industries. This unit is very popular in workshops as a good workhorse. This fixed straight hand piece is ideal for any deburring or polishing job. This tool has constant variable speed from 0 to 50,000rpm so ideal for many applications from drilling and deburring jewellery to polishing plastics and resin.

- Variable speed motor from 0 to 50,000 RPM
- High Torque 8.2 N.cm
- 240V
- 200 Watts – High power machine
- Vibration – popular for companies reducing risk of white finger.
- Right and Left Rotation – ideal for deburring and working up to tight edges.
- Comes with a 3mm Collet or 2.35mm (3/32")
- Twist quick collet release for quick and easy tool change. No spanners needed.
- Foot speed control included
- Built in Micro Processor
- Brushless motor



MAXFORCE B150

✓  
ORDER REF- SAESHIN/B150/  
FORTE10011P/SET

**A COLLET REDUCER makes changing between spindle sizes very simple. It fits inside a 3mm collet converting it to take a 2.35mm.**



### COLLETS

	2.35MM	3MM
MAXFORCEB150	✓	✓
ORDER REF - SAESHIN/F400PSP/COL- (SIZE)		
BRILLIAN B150	✓	✓
ORDER REF - SAESHIN-102LCOL- (SIZE)		
REDUCER		
3MM - 2.35MM	✓	
ORDER REF - REF - SAESHIN/REDUCER3.0/2.35MM		

## BRILLIAN B350

- Speed control up to 40,000 rpm – variable speed
- Good torque 280gf.cm
- 240v
- 20 Watts
- Includes a foot pedal controller
- Left and right rotation
- Bench tool rest

The micromotor system Brillian B350 is an excellent electric system, ideal for all metal or plastic detailed work. Variable speed control up to 40,000 rpm which allows good control for various applications. Supplied with a 2.35mm collet.



BRILLIAN B350 MICROMOTOR

**FULL SYSTEM** ✓  
ORDER REF - SAESHIN/B350/BRILLIAN



## URAWA/UHANDY SYSTEM

A range of options for stoning, filing, polishing and high speed rotary work. From the sophisticated ultrasonic system to the lowest cost micromotor system. Ask for our detailed price list showing the integration of all the parts and systems in the URAWA range



## URAWA FIXED HANDPIECE

This is a fixed motor and handpiece that plugs into the control box. This option is simple to use and cost effective.



## BS33 BELT SANDER

Belt speed: 77.7~777m/minute  
Dimensions: L160 x H119mm



## RE35/RE55 RECIPROCATOR

### RE35

Stroke Length: 0-6mm  
Frequency: 420-4200

### RE55

Stroke Length: 0-2mm  
Frequency: 700-7000



**FOOT CONTROLS - ON/OFF SWITCHES - EXTENSION CORD**

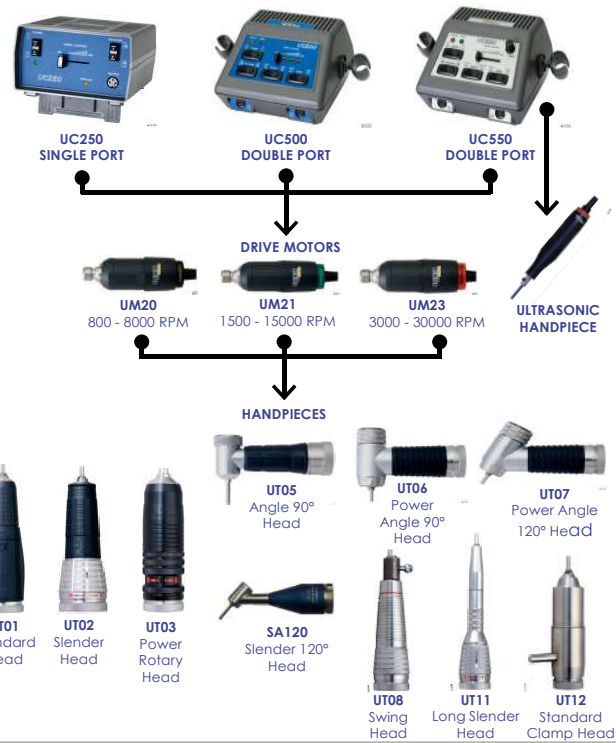

URAWA FIXED HANDPIECES			
	UA12A	UA13A	UA14A
<b>RPM</b>	2000- 20000	3500- 35000	4500- 45000
<b>TORQUE</b>	6.5N.CM	5.4N.CM	4.1N.CM
<b>MOUNTED COLLET CHUCK</b>	2.34MM		
<b>INCLUDED COLLET CHUCK</b>	3.00MM		
<b>ORDER REF - UHUA(No)</b>			



## COMPLETE SYSTEM

A popular pairing of control box and fixed handpiece.



## U15 REDUCTION JOINT

- For reducing speed to 1/4
- Up to 30000 RPM allowable speed
- Fits between head and motor



## HM11 HAMMER/ENGRAVING HANDPIECE

- Possible to adjust strokes and power.
- Ideal for stone setting and engraving.
- Particularly for Jewellers.

## FBS240/E PRECISION DRILL/ GRINDER 28472

Very low vibration at tip & very light. Runs from 5,000rpm, ideal for delicate jobs  
Chuck as standard  
Strong permanent magnet motor  
5,000-20,000rpm  
100W  
Keyless chuck (0.3 to 3.2mm)  
Length - 185mm, Weight - 450g  
Complete with 40 accessories



FBS240/E	
28472	✓
ORDER REF - PROXXON-28472	

## IBS/E PROFESSIONAL DRILL/ GRINDER 28481

Quiet powerful motor  
Streamlined head of die-cast aluminium for exact bearing seats and optimal stability  
Runs from 5,000 to 20,000rpm  
100W  
6 collets (1.0, 1.5, 2.0, 2.4, 3.0, 3.2mm)  
Length - 230mm, Weight - 500g  
Complete with 34 accessories



110/P FLEXSHAFT	
28620	✓
ORDER REF - PROXXON-28620	

# PROXXON

## 110/P FLEXI SHAFT 28620

Highly flexible 1m shaft  
Delicate handpiece for precision  
Supplied with collets (1.0, 1.5, 2.0, 2.4, 3.0, 3.2mm) (To fit either drill/grinder)



IB/E	
28481	✓
ORDER REF - PROXXON-28481	

## MAXIMA NEO ELECTRIC MICROMOTOR

- Speed control from 2,000-35,000
- High Torque 6.5N/CM
- Comes complete with foot control
- PHP35 Quick release handpiece
- Left and right rotation
- Bench tool rest
- Fixed straight hand-piece with 3mm collet. Collets available in 3.2, 2.35 and 1.6mm



MAXIMA NEO	
✓	
ORDER REF - MAXIMA-SYSTEM	

## ENESKAMOBILE CORDLESS GRINDER SYSTEM

The set contains the following components:

- ENESKAmobile control unit (Order No. 0 012 301)
- ENESKAmobile charger incl. power pack (Order No. 0 012 302)
- ENESKAmobile battery pack (order No. 0 012 303)
- ENESKAmicro COMPACT JEM 50C, motor incl. quick-action chuck with Ø 3 mm collet and motor cable (order no. 0 100 001)
- Plastic case (order No. 0 012 304)



ENESKA MOBILE	
✓	
ORDER REF - ENESKA-0012300	

## ENESKA SONIC - ULTRASONIC LAPPING & POLISHING SYSTEM

The most innovative advancement in the field of ultrasonic polishing. ENESKAsonic – high-efficiency, leading-edge, latest generation for finest stock removal. An outstanding sophisticated design combined with convenient high-tech equipment.

### Highlights:

- Intuitive high-quality glass touch operation with rotary controller,
- Modern LED-assisted multi-functional display
- Boost function for applications requiring greater power
- Auto-Tune function determines the optimum frequency
- Idle timer detects unused handpieces and protects against wear
- The 140 g lightweight handpiece enables fatigue-free work.
- Reverse-compatible with ENESKA 2-1 handpieces.
- USB charging connection
- “100% Made in Germany”



ENESKA ULTRASONIC SET	
Complete System	✓
ORDER REF - ENESKA-0012000	

Includes tool holders with 3mm dia bore, 3mm slot width and 1mm slot width

### The set contains the following components:

- 1 x control unit ENESKAsonic (Order No. 0 012 001)
- 1 x ultrasonic handpiece JUS-45PB-ES (Order No. 0 012 003)
- 1 x handpiece support, standard, black (Order No. 0 011 110)
- 1 x tempered glass screen protector (Order No. 0 011 098-G)
- 1 x power cord set (Order No. 0 007 435-1)
- 2 x 4 A fuse for 110 V use (Order No. 1 711 407-1)
- 1 x allen key (Order No. 0 006 304)
- 2 x chuck key (Order No. 0 006 347)
- 1 x tool holder – Ø 3 mm bore (Order No. 0 006 306-E)
- 1 x tool holder – 1 mm slot width (Order No. 0 006 310-E)

**We recommend Xebec ceramic stones for ultrasonic polishing.  
See page 19. Diamond machine files can also be used.**

## FOREDOM®

We now offer Freedom pendant motors as a modular system, select the handpiece to suit the work you are doing. The great advantage of a Freedom pendant motor is the large selection of interchangeable handpieces that are available. We keep the most popular options in stock.



FOREDOM SR	
<b>SR (NO HANDPIECE)</b>	✓
ORDER REF - FOREDOM-TYPE-SR	

### HANDPIECE H.20

Exclusively for 2.35mm shanks, quick release handpiece with lever action. Suits jewellers particularly who use mainly 2.35mm burs. 1 1/8" Diameter (center) 3/8" diameter (front taper)



H.20	
<b>QUICK CHANGE (3/32")</b>	✓
ORDER REF - FOREDOM-HP-NO.20	

### HANDPIECE H.30

A general purpose chuck handpiece. No collets, the jaws clamp down on the burr. Takes up to 4mm shanks. 1" diameter.



H.30	
<b>CHUCK SYSTEM</b>	✓
ORDER REF - FOREDOM-HP-H30	

### HANDPIECE H.28

A tapered/ slender handpiece that is easy to hold. Comes with a 3/32" (2.35mm) and 1/8" (can clamp down to a 3mm) collets. 23/32" Diameter (center), 1/2" diameter (taper)



H.28	
<b>TAPERED (3/32" &amp; 1/8")</b>	✓
ORDER REF - FOREDOM-H28	

### HANDPIECE H.44T

A tapered general purpose handpiece. Comes with 3/32", 1/8" & 1/4" collets. 1" diameter (center), 3/4" diameter (taper)



H.44T	
<b>3/32", 1/8", 1/4"</b>	✓
ORDER REF - FOREDOM-HP-NO44T	

### HANDPIECE H.8

A slim handpiece with chuck guard which slides back when changing burs. It has a collet system and comes with 3/32" & 1/8" collets. 5/8" Diameter



H.8	
<b>SLIM C/W 3/32 &amp; 1/8"</b>	✓
ORDER REF - FOREDOM-HP-NO.8	

### 35RAA HANDPIECE FOR FOREDOM

Head can be swivelled and telescopic extended. Will take collets 2.35mm.(3/32"), 3mm & 1/8". Complete with 1 collet of choice



35RAA	
<b>Right Angled Handpiece</b>	✓
ORDER REF - FOREDOM-R/AHP	

TOOLS & EQUIPMENT





The WeCheer system offers excellent value for money. Replacement parts available. Interchangeable handpieces.

**Specification:**

Maximum speed up to 20,000 rpm

**WeCheer Pendant Motor, complete with:**

- Motor
- Shaft
- Foot Control



Image	Description	Order Ref
	WeCheer Slim 2.4mm & 3.2mm Collet	26511
	WeCheer Slim 0.8mm to 3.2mm Collet	26512
	WeCheer Standard With 2.4mm, 3.2mm, & 4mm Collets	26513
	WeCheer Standard 0-4mm Chuck	26514
	WeCheer Carving handpiece with 5 chisels	26515
	WeCheer Snap-Lock 3.2mm Collet	26516
	WeCheer Right-Angle, 2.4mm & 3.2mm Collet	26517
	WeCheer Large 1/4 Chuck	26518

WE CHEER PENDANT MOTOR	
OPTION	
WE CHEER SYSTEM (NO HANDPIECE)	✓
ORDER REF - WE CHEER	
KITS	
KIT 1 - SYSTEM + STRAIGHT HANDPIECE	✓
KIT 2- SYSTEM + RIGHT ANGLE HANDPIECE	✓
KIT 3 - SYSTEM + SLIM 2.4 & 3.2 COLLET, STRAIGHT HANDPIECE	✓
ORDER REF - WE CHEER	

**No1 Slip Joints**  
Both Milbro and Faro pendant motors come with a no1 slip joint. Select a handpiece from page 142 to fit these machines.

**MILBRO PENDANT DRILL**

Sturdy British made 'workhorse'

- Supplied with a no1 Slip Joint
- Includes foot control

**\*Can also be supplied with a fixed handpiece for a reduced price.**

- Fixed handpieces come complete with 4 collets (chucks), Zero, 1/16, 3/32, 1/8, which allows you to accept tool diameters of 0.01mm - 3.00mm.



MILBRO PENDANT MOTOR	
18,000 RPM	✓
ORDER REF - PENDANTSYS-MILBRO	

TOOLS & EQUIPMENT

# NO1 SLIP JOINT HANDPIECES & PENDANT MOTOR STANDS



## HANDPIECES TO SUIT No1 SLIP JOINTS

A range of handpieces to suit flexible shaft/ pendant drills with no1 slip joints.

### 35VB HANDPIECE

Will take collets 2.35mm. (3/32"), 3mm, 6mm, 3/32", 1/8" and 1/4"  
Complete with one collet of choice.



35VB	
LARGE STRAIGHT	✓
ORDER REF - MG535VB	

### SST HANDPIECE

Complete with a 3mm collet, other collets available



SST	
SMALL STRAIGHT	✓
ORDER REF - MG5STRH/P	

### 35RAB HANDPIECE

Will take collets 2.35mm (3/32"), 3mm, 6mm, 1/8" and 1/4". Complete with 1 collet of choice



35RAB	
LARGE RIGHT ANGLE	✓
ORDER REF - MG535RAB	

### 35RAA HANDPIECE

Head can be swivelled and telescopic extended. Will take collets 2.35mm (3/32"), 3mm & 1/8". Complete with 1 collet of choice.



35RAA	
SMALL RIGHT ANGLE	✓
ORDER REF - MG535RAA	

### COLLETS

To suit the above handpieces

### MOBILE STAND

On castors, complete with **double** hook, (single hook illustrated). Height is adjustable

MOBILE STAND	
MOB-1	✓
ORDER REF - MOBILEPENDANTSTD	



### FARO PENDANT DRILL SPECIFICATION:

Motor: 22,000 rpm max.  
Output: 300watts  
Cable Arm: Inner drive and No. 1 quick release slip joint. High speed twin bearing, convoluted outer.

\*HANDPIECE NOT SUPPLIED

### FARO OPTIONAL EXTRAS

Replacement Flexible Drive Shaft: 6mm diameter cable for longer durability with tough stainless steel outer casing. Slip-joint quick release for handpiece changing.



FARO PENDANT MOTOR	
22,000 RPM	✓
ORDER REF - PENDANTSYS-FARO	

TOOLS & EQUIPMENT

### PENDANT MOTOR STAND

Pendant motors are designed to be hung to keep the flexshaft straight and at a good height for working.

Single hook stands with the option of either being fixed to the bench or moveable with a G-clamp base. Height is adjustable.

PENDANT MOTOR STANDS	
TYPE	
FIXED OPTION or G-CLAMP OPTION	✓
ORDER REF - PENDANTMOTOR-STAND	



Moveable g-clamp option



Fixed option

**JOKE PREMIUM PENDANT MOTOR**

With an output of 800 WATT, 22,000– 1,000 RPM. Silky smooth to use with fantastic power

**SYSTEM INCLUDES:**

Motor, Flexible Shaft with No1 Slip Joint and Foot Pedal.

800 WATT output is enough power to drive 3" diameter wheels. Motor can be used hanging or laid flat. Has a strong shaft and cable

PREMIUM PENDANT MOTOR	
<b>800 WATT, 1-22,000RPM</b>	✓
<b>ORDER REF - JOKE-0016850</b>	

**HANDPIECES**

See page 40 onwards in the Joke catalogue for the Joke range to suit. Please contact us for advice.

**Motor jokeFlex Premium Plus**  
Order no. 0 016 550

**Flexible shafts Premium Plus**  
Standard motor connection  
Expanding ring 1.1 m Order No. 0 015 800  
Rapid-Change 1.1 m Order No. 0 015 900  
Quick-Change motor connection  
Expanding ring 1.1 m Order No. 0 016 800  
Rapid-Change 1.1 m Order No. 0 016 900

**Handpiece joke Premium Plus**  
Order No. 0 030 200

**Angle-handpiece joke Premium Plus**  
Order No. 0 030 250

**Angle-handpiece 90° Classic Plus**  
Order No. 0 030 280

**Handpiece THSZ/N**  
Order No. 0 030 004

**Angle-handpiece VTN-N 90°**  
Order No. 0 031 341

**Angle-handpiece VTN-N 135°**  
Order No. 0 031 342

**Telescope piece 90°**  
Order No. 0 031 343

**Telescope piece 135°**  
Order No. 0 031 344

**Angle-handpiece VTN-S/W**  
Order No. 0 031 540

**Rapid-chuck handpiece TH-M II**  
Order No. 0 030 640

**Suspension device, clamp-on**  
Order no. 0 020 100

**Foot control Premium**  
Order no. 0 016 600

**Quick coupling system joke Rapid-Change**  
Coupling piece  
Order no. 0 015 250  
Connector plugs for handpieces see page 44/45!

**DIPROFIL® Hand-filing machines Di-Pro**  
FKK Order No. 0 001 503

**DIPROFIL® Hand-filing machines**  
FPB/R Order No. 0 001 151  
FPK/R Order No. 0 005 151

**Straight handle unit NHG-L**  
Order No. 0 031 400

**FLEXTOL VARIABLE SPEED HEAVY DUTY 2HP - FLEXIBLE SHAFT MACHINE**

This excellent quality flexible shaft machine is ideal to use larger mops on for polishing larger items which cannot be lifted to a floor standing polisher.

This is a 2 HP machine and has variable speed from 1,000 to 10,000rpm. It offers good torque at lower speeds.

**This includes:**

A 6mm straight hand piece with a 6mm chuck. A taper cone for use with mops and wheels. A caster base 22" diameter with 4 wheels.



FLEXTOL VARIABLE SPEED	
<b>2 HP 1,000-10,000 RPM</b>	✓
<b>ORDER REF - FLEXTOL-IVS/LS2HP</b>	

**TOOLS & EQUIPMENT**



# TUBE/PIPE LINISHERS & BELT SANDERS



## TUBE & PIPE LINISHERS

The finishing attachment allows Trizact, felt and standard belts to be used on all tube work. You can now achieve a mirror finish on tube work without using a mop. The sprung loaded wheels allow the belts to wrap around the tube. We offer several options.

## BELT FILE FOR DETAILED LINISHING

Each machine comes with a choice of 5 arms.

## PNEUMATIC BELT FILE

0.5 Horsepower Motor



## ELECTRIC BELT FILE

570 Watt  
9,000 RPM  
240 & 110 Volts



<p><b>Arm operating 12mm wide belt</b></p> <p>Standard 12mm arm – general purpose. Grind, deburr, splatter remove, polish and finish. For use on wheel or platen pads. (Cork for grinding, rubber for finishing)</p> <p>Arm BF012 operates 12mm wide x 457mm long belts Arm BF012/5 operates 12mm wide x 533mm long belts Arm BF012/6 operates 12mm wide x 610mm long belts</p>	<p>18.0 D — </p> <p>Rubber — </p> <p>9.0 W — </p>
<p><b>Arm operating 19mm wide belt</b></p> <p>Grind &amp; finish; Stock removal; Working large areas; For use on wheel or platen pads. (Cork for grinding, rubber for finishing)</p> <p>Arm BF019 operates 19mm wide x 457mm long belts Arm BF019/5 operates 19mm wide x 533mm long belts Arm BF019/6 operates 19mm wide x 610mm long belts</p>	<p>18.5 D — </p> <p>Rubber — </p> <p>15.3 W — </p>
<p><b>Arm operating 6mm or 12mm wide belt</b></p> <p>Use for blending internal radii and stock removal on the wheel. Outside radiusing with 12mm belt behind wheel on slack of belt to produce flat free finish.</p> <p>Arm BF006 operates 6 or 12mm wide x 457mm long belts Arm BF006/5 operates 6 or 12mm wide x 533mm long belts Arm BF006/6 operates 6 or 12mm wide x 610mm long belts</p>	<p>24.0 D — </p> <p>Rubber — </p> <p>9.0 W — </p>
<p><b>Arm operating 3mm wide belt</b></p> <p>Grind &amp; finish; Narrow small welds; internal radii; tight angles. Driven wheel shaped to a V, gives excellent tracking to a 3mm belt. Allows for very neat dressing of welds.</p> <p>Arm BF003 operates 3mm wide x 457mm long belts Arm BF003/5 operates 3mm wide x 533mm long belts Arm BF003/6 operates 3mm wide x 610mm long belts</p>	<p>24.0 D — </p> <p>Rubber — </p> <p>9.0 W — </p>
<p><b>Arm operating 4 or 6mm wide belt</b></p> <p>Grind &amp; finish; Working slots and narrow channels. To be operated in straight line.</p> <p>Arm BF004 operates 4 or 6mm wide x 457mm long belts Arm BF004/5 operates 4 or 6mm wide x 533mm long belts Arm BF004/6 operates 4 or 6mm wide x 610mm long belts</p>	<p>18.7 D — </p> <p>Rubber — </p> <p>3.9 W — </p>

BELT FILE		
Number of Arms	AIR	ELECTRIC
1 arm BF012 (12 x 457mm arm)	✓	✓
3 arms (BF003, BF006 + BF012)	✓	✓
4 arms (BF003, BF006, BF012 + BF019)	✓	✓



## PIPE SANDER UTG 9R

Power - 1050 watt  
Belt Speed - 7-15.5 m/sec  
Pipe Diameter - 70mm max  
Belt size - 30 x 610 mm



## PIPE SANDER LRP 1503 VRA

Power - 1200 watt  
Belt Speed - 4-12 m/sec  
Pipe Diameter - 125mm max  
Belt size - 20 x 760 mm  
& 40 x 760 mm



## PIPE SANDER RS 12-70 E

Power - 1200 watt  
Belt Speed - 22 m/sec  
Pipe Diameter - 80mm max  
Belt size - 20 x 815 mm  
& 40 x 815 mm

TOOLS & EQUIPMENT



## JOST PIPE SANDING & FINISHING SYSTEM

A clever system for use with an angle grinder (not included)



JOST PIPE FINISHING SYSTEM	
Complete Kit with Abrasives	✓
For tubes 10mm to 76mm dia	✓
ORDER REF - JOST-2000-1	



**MINIFIX 25-R SET**

Comprising:

Fully insulated motor, 3m cable + plug, flexible shaft NA4 x 1250mm DIN 10/G16, FH4 straight handpiece c/w 6mm collet, set of tools, all in metal carrying case.



**HEAVY DUTY PENDANT MOTOR**

- Integral variable speed selector – 11000 to 25000 rpm
- Lightweight and compact, guarantees work without operators fatigue
- Delicate right angle and straight hand pieces for optimal application use.
- 110v or 230v available.

**APPLICATIONS:**

Tool and patternmaking, aerospace and aircraft industry, precision mould and die-maker shops, engine tuning, dental labs, wood modelling, glass engraving, etc for use with tungsten carbide burrs, mounted points, flap wheels (up to 40mm dia), circular wire brushes (up to 40mm dia), felt polishing bobs & non woven fibre brushes.

MINIFIX 25-R	
ACCESSORIES	
FH4 Straight Handpiece c/w 6mm collet	✓
Wi4 90 deg Handpiece c/w 3mm collet	✓
Complete Shaft NA4 x 1250mm	✓
Collets for FH4: 3/32" 1/8" 3mm 1/4" 6mm	✓
Collets for Wi4: 1/8" 3mm 6mm	✓

**ROTOMAX 2.0**

**The most powerful drive - for your coarse grinding tasks.**

The suhner flexible shaft ROTomax 2.0 is a powerful and universal unit, in which the drive and the tool are run separately using a flexible shaft.



Suhner flexible shaft machine – ROTomax 2.0 – Complete with stand and FH10 handpiece with a 6mm collet.

SUHNER ROTOMAX 2.0	
SUHNER-ROTOMAX2.0	✓

**PERFORMANCE DATA:**

- Speed range: 500 – 13,000 rpm
- Power input: 2,000 W
- Power output: 1,650 W
- Mains voltage: 1 x 230 / 240 V (50 / 60 Hz)
- Overload protection: yes
- Weight: 28 kg
- Sound pressure level: 77 dB(A)



**FLEX RANGE OF GRINDERS & POLISHERS**  
Excellent value for money and great features



**BURNISHING TRINOXFLEX**  
**FLEX-BSE14-3100-240V** ✓

**BSE14-3 100**  
Power: 700w  
Weight: 2.9kg  
No load speed: 1000-3500 rpm

There are a range of accessories for this machine making this a truly universal tool.

## ACCESSORIES FOR THE ABOVE

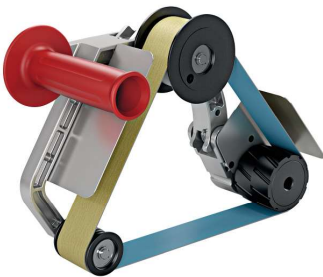

**SANDING ATTACHMENT, PIPE BELT:**  
Tool free fitting via quick change system  
Belt size: 760x40mm

**BR 125 PIPE BELT**



**SANDING ATTACHMENT, BELT FILE**  
Includes 9mm and 30mm sanding arms.  
Belt size: 533x9mm

**BF 140 BELT FILE**



**SANDING ATTACHMENT, BURNISHING**  
Tool free fitting via quick change system  
MAX wheel size Ø110x100mm

**BS 100**

TOOLS & EQUIPMENT



**FILLET WELD GRINDING ATTACHMENT**  
Tool free fitting via quick change system  
MAX wheel size: Ø152mm

**LK 152**



M14 taper cone sold separately, this is necessary for use with polishing mops, lap disc mops etc.

**PLUS GUARD, HANDLE ETC**  
**FLEX-LP1503VRPLUS** ✓



PNEUMATIC DRUM	
Dimensions	
<b>90 X 100 X 19mm</b>	✓
ORDER REF - BLOWUPTYRE90X100	
ARBOR	
Dimensions	
<b>FG M14 (19 X 100mm)</b>	✓
ORDER REF- BLOWUPTYRE-ARBOR	



**GRINDERS & POLISHERS**

All are available in 230V and 110V

TOOLS & EQUIPMENT

**SG6 VARIABLE SPEED STRAIGHT GRINDER**  
1600 W 1,600 - 4,800 rpm also comes with taper cone  
**Replacement for the EDX SG30.**

SG6 STRAIGHT GRINDER	
<b>110V OR 230V</b>	✓
ORDER REF - SG6	



**FOREDOM BENCH LATHE M.BL**

An excellent polisher for smaller items, particularly jewellery, dental and precision items.

- 1/6 horsepower, high torque motor
- 230 Volt
- **Speed Range: 500-7,000 rpm**
- 125 Watts (continuous rating)
- Motor shaft diameter: 5/16" (8mm)
- Height: 5 1/8" (130mm)
- Width: 13" (330mm) between spindles
- Weight: 7.5 lbs (3.4 kg)
- CSA Certified
- CE rated



<b>FOREDOM BENCH LATHE M.BL</b>	
<b>230 volt - 1/6 horsepower</b>	✓
<b>ORDER REF - FOREDOM-MBL</b>	

**FOREDOM DUST COLLECTOR HOODS - MADCH-1**

For collecting dust and residue created from polishing and grinding materials. These compact hoods are constructed from heavy gauge sheet metal, with non-skid pads on the bottom. Has a 64mm adapter that fits most dust collection system hoses. Measures 165mm h. x 219mm d.



<b>FOREDOM FILTER DUST HOOD</b>	
<b>TYPE</b>	
<b>MAFH25 110 or 220</b>	✓
<b>MADCH-1</b>	✓
<b>ORDER REF - FOREDOM</b>	

TOOLS & EQUIPMENT

**6" HEAVY DUTY BENCH GRINDER**

450 WATT

Takes a 13mm Pigtail

This 6" Bench Polisher is ideal to be converted into a polisher for all metal finishing and deburring. This heavy duty model is good for constant use for general workshop use. Recommended for use as a grinder and comes with stones. Can also be used with deburring wheels which is ideal for deburring edges of metal components. Also attaching a spindle or pigtail will convert this bench grinder into a polisher – so allowing mops to be wind on and off easily.



8" Version also available

<b>6" HEAVY DUTY XD199</b>	
	✓
<b>ORDER REF - BENCHGRIND-BG150XD/99</b>	
<b>8" HEAVY DUTY BG200/99</b>	
	✓
<b>ORDER REF - BENCHGRIND-8"SPECIAL</b>	





**DSM200**

Heavy Duty Industrial Bench Polisher.

- 1.2 HP
- 900 Watts
- Single Phase
- Takes 20mm tapers



See Page 155 for more options.

**AEG POLISHING MOTOR**

Specification

A range of robust bench polishers complete with tapered spindle ends



1 - Phase or 3-Phase  
On/Off Power Switch  
See pages 155 for alternative detachable Spindle Ends

TOOLS & EQUIPMENT

DOUBLE-ENDED BENCH POLISHER			
HP	RPM		Recomended Taper
1.5	2820	✓	No 2
2	2815	✓	No 3
3	2815	✓	
<b>Slow Speed Polisher for Plastics</b>			Taper
0.75	1395	✓	No3
1.5	1435	✓	
<b>TAPER NOT INCLUDED</b>			
All above c/w direct on-line starter			
<b>ORDER REF -POLISHER(HP)</b>			
<b>FLOOR STANDING PEDESTAL</b>			
<b>Optional Extra</b>	✓	ORDER REF -POLISHER-BENCHSTAND	

Two speed polisher, allows slower speeds for temperature sensitive parts

BENCH STANDS & HOODS	
Motor with Bench stand	Bench mounted Hoods with 4" Dia outlets
✓	✓
<b>ORDER REF - POLISHER...</b>	



## P-200M

Double ended bench polisher.

- Medium Duty
- 0.9 HP
- Single Phase
- 6" Mops
- 2800 RPM



OPTIONAL  
EXTRA



## P-10

Double ended polisher

- 1 HP
- Single Phase
- 8" mops
- Extraction ready
- 2800 RPM
- Optional extra pedestal



Hp	W	RPM	Brushes mm ø mm	weight
6,00 3~	4400	2800	300x35x25/30	188,0

## PA-8

Double ended polisher with dust extraction.

- Up to 12" Mops
- 6.0 HP
- Extraction ready
- 3 Phase
- 2800 RPM



**SLA4**

- 2.03 H/P
- RPM 1400
- Belt size: 2000mmx50mm
- 24v power switch BT1
- 3 phase



**SL-3**

- 1.6 H/P
- RPM 2800
- Belt size: 1500mmx120mm
- 1200w



**SL-1**

- 1 H/P
- RPM 2800
- Belt size: 100mmx50mm
- 750w
- Single phase
- Adjustable arm

**MORE OPTIONS AVAILABLE - Please Enquire.**

**FLOOR FIXED PEDESTALS**



**MOP GUARDS**



**FLOOR TYPE IDLER BACKSTAND No. 2641**



**TOOLS & EQUIPMENT**

**VERTICAL TYPE IDLER BACKSTAND No.3596**

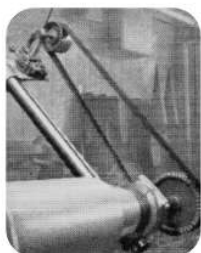

**BELT GUARDS**

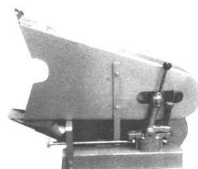

**FLOOR STANDING CANNINGS MACHINE**



**H/D BACKSTAND IDLER**

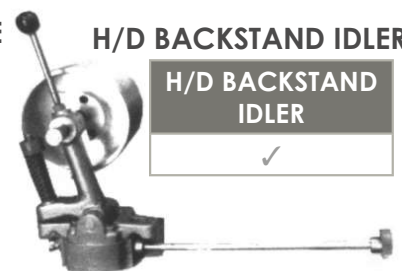

**H/D BACKSTAND IDLER**



**MM506**  
Reverse Threaded  
on 6mm Shank



**MM304D**  
1/8" Shank



**MM301**  
3/32" Shank



**MM17**  
6mm Shank



**MM32**  
6mm Shank



**MM304DM**  
3mm Shank



**MM504**  
3mm Shank



**PB 38**  
6mm Shank



**PB 39**  
6mm Shank



**MM39**  
6mm Shank



**MM305D**  
1/8" Shank



**MM5**  
1/8" Shank



**MM503**  
3/32" & 3mm Shank

**MANDRELS**  
On various spindles to suit a range of felts and wheels. **Sold Per Mandrel**

MANDRELS						
Order Ref.	Type	Shank	For bore	For wheel	For use with	
			size	thickness		
MMNo.6	Small Point	1/8"	1/8"	1/2"	Small felt wheels	✓
MM304D	Small Straight	1/8"	1/4"	1/8"	MX & slitting wheels 1" dia. Felt wheels	✓
MM503-2.35	Small Straight	3/32"	1/16"	1/4"	Rubber bonded wheels	✓
MM503	Small Straight	3mm	1/16"	1/4"	and diamond discs	✓
MM304DM	Small Screw Top	3mm	3mm	2mm max	25mm Diamond Discs	✓
MM305D	Small Tapered	1/8"	1/16"	1"	Very small felt wheels	✓
MM301	Small Tapered	3/32"	1/16"	1/2"		✓
MM506	Straight Threaded with Bolt and 2 Washers	6mm	6mm-8mm	Up to thread capacity	Habras, felt, unitized, mx etc	✓
MM17	Tapered	6mm	1/4"	1" to 2.5"	Small felts & dollie mops	✓
MM32	Tapered	6mm	1/4"	3" to 6"	Large mops up to 6" dia.	✓
PB38	Extended Tapered	6mm	1/4"	1/2" to 3"	Small felts & dollie mops	✓
PB39	Tapered	6mm	1/4"	1/2" to 4"		✓
MM39	Straight	6mm	1/4"	1/2"	Larger felt wheels	✓
MM504	Small Taper	3mm	~	~	Small Wheels	✓
MM5	Small Straight	1/8"	~	~	Cut Off Wheels	✓



MM11



MM14



MM15



MM13

### SPLIT PIN MANDRELS

A really simple way to smooth inside bores. Simply wrap with a strip of wet and dry paper. Very popular in the jewellery trade.

2.35mm Spindle

**Sold Per Mandrel**



SPLIT PIN MANDRELS			
Order Ref.	Head Size	Slot Length	
	(mm)	(mm)	
MM11	4.5 dia x 25	20	✓
MM14	3.1 dia x 25	20	✓
MM15	2.35 dia x 12	12	✓
MM13	5-2 dia x 25	18	✓



## SPECIAL PIGTAIL

This pigtail features an 'end hole' with grub screw for taking small mounted bobs and wheels. Takes up to 3mm spindles.

**Sold Per Pigtail (choose Left or Right hand)**

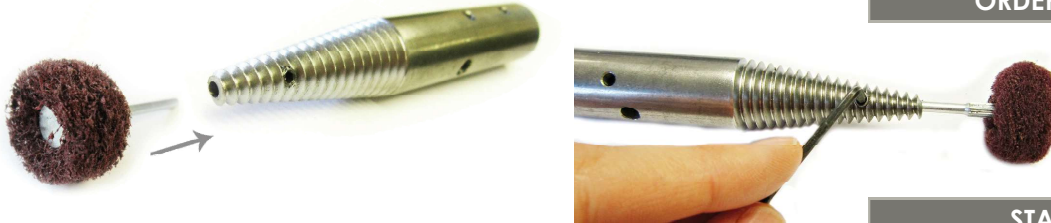

PIGTAILS WITH END HOLE		
Size	Side	
12mm with end hole	R/H & L/H	✓
16mm with end hole		✓
ORDER REF - PIGTAIL(SIZE)		

## STANDARD PIGTAIL

Standard pigtails available in a couple of sizes to suit popular sizes of grinder. Used to adapt a grinder into a polisher for using mops. Has **no** end hole for mounted products.

**Sold Per Pigtail (choose Left or Right hand)**



STANDARD PIGTAILS		
Size	Side	
12mm	R/H & L/H	✓
13mm		✓
16mm		✓
20mm		✓
ORDER REF - PIGTAIL(SIZE)		

## TAPER CONE WITH M14 INTERNAL THREAD

The taper cone allows a range of items to be wound onto the end. Available in other sizes. Mainly designed for Angle Grinders.

**Sold Per Taper Cone**



TAPER CONE	
SIZE	
M14 THREAD	✓
ORDER REF - TAPERCONE	

## DETACHABLE SPINDLE ENDS

TYPE 'A'

For use with taper screw.



TYPE 'B'

For mounting mops or wheels between plates on parallel shaft and smaller mops on taper screw.



TYPE 'C'

For mounting mops between plates on parallel shaft.

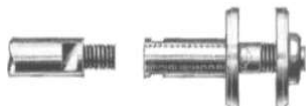

TYPE 'D'

Similar to 'B' but with detachable taper screw.

When ordering, please state:

- 1) Type of spindle end required;
- 2) RH, L.H, or both ends;
- 3) Diameter, and thread per inch (of axel) if required.



## LARGE TAPER SPINDLE ENDS

To suit larger polishers.

LARGE PIGTAILS		
Size	Internal dia	
No1	14mm	✓
No2	19mm	✓
No3	24mm	✓
ORDER REF - TAPERSPINDLES(No)		





**PUMA AIR BELT SANDERS**  
B10 & B20 Air driven belt sanders



**B20 SANDER**  
20mm Belt Sander  
16,000 RPM



**B10 SANDER**  
10mm Belt Sander  
16,000 RPM

**BELTS FOR B10 & B20 BELT SANDERS**  
Sold per 50

**DUAL ACTION ORBITAL SANDER**  
75mm or 50mm diameter  
With a soft ergonomic handle



ORBITAL SANDER	
SA701	✓
ORDER REF - AIRORBITAL	

PUMA BELT SANDERS						
MODEL	AIR INLET	AIR HOSE	Avg. Air	Working Air	Suggest Air	
	(PT)	(ID)	Consumption (cfm)	Pressure (psi)	Compressor (HP)	
B10	1/4"	3/8"	6	90	2	✓
B20	1/4"	3/8"	6	90	2	✓

ORDER REF - B10 (OR B20)

SPARE BELTS					
PER 50	BELT SIZE	40g	60g	80g	100g & finer
B10	330 X 10MM	✓	✓	✓	✓
B20	520 X 20MM	✓	✓	✓	✓

ORDER REF - AB(SIZE)

CONSUMABLES FOR 2" ORBITAL SANDER				
2" Dia. Velcro Backed Al/Ox Sanding Discs (per 100)				
Grits	60	120	180	240 & 400
	✓	✓	✓	✓
2" Dia. Scotchbrite Surface Condition Discs (per 20)				
Grades	Coarse - Brown	Medium - Red	Fine - Blue	
	✓	✓	✓	
2" Dia. Wet & Dry Velcro Backed Discs (per 50)				
Available in all grits down to 3000. Please contact us for Prices				
2" Dia. Felt Discs - Velcro Backed (per 20)				
Grades	Soft / Medium 6mm thick			✓

PUMA AIR ENGRAVER			
AT6062	✓		
49.7Hardened Needles for Engraver			
Medium	✓	Fine	✓
ORDER REF - AIRENGRAVER			

PUMA AIR TOOL CONSUMABLES	
CONSUMABLES	
3MM COLLETES FOR TYPE G ONLY	✓
1/8", 6MM, 1/4" COLLETS	✓



**HARDENED NEEDLES FOR ENGRAVER**  
Available in Medium & Fine

### AT-7033

6mm Straight Die Grinder  
22,000RPM



#### STRAIGHT DIE GRINDER

**AT-7033** ✓

ORDER REF - AIRDIE

### AT-7033L

6mm Extended Die Grinder  
25,000RPM



#### EXTENDED DIE GRINDER

**AT 7033L** ✓

ORDER REF - AIRDIE

### AT-7032

6mm Mini Die Grinder  
25,000RPM



#### MINI DIE GRINDER

**AT-7032** ✓

ORDER REF - AIRDIE

### AT-7034

6mm Angle Die Grinder  
20,000RPM



#### ANGLE DIE GRINDER

**AT-7034** ✓

ORDER REF - AIRDIE

### AT-7136M

115 Deg. Angle Die Grinder  
Comes with 6mm collet  
20,000RPM



#### 115 DEG DIE GRINDER

**AT-7136M** ✓

REF - AIR-AT7136M

### TYPE G - AT3170

3mm Micro Pencil Grinder  
58,000RPM. Comes with airtight hose,  
over hose and 3mm collet.  
(Will take 3/32" and 1/8" collets)



#### TYPE G

**AT-3170** ✓

ORDER REF - AIRMICRO

### TYPE G - AT3180 (HIGH SPEED)

3mm Micro Pencil Grinder  
70,000RPM. Comes with a 3mm  
collet. (Will take 3/32" and 1/8"  
collets)



#### TYPE G - HIGH SPEED

**AT-3180** ✓

ORDER REF - AIRMICRO

### PUMA AIR TOOL SPECIFICATIONS

MODEL	AIR INLET	AIR HOSE	Avg. Air	Working Air	Suggest Air
	(PT)	(ID)	Consumption (cfm)	Pressure (psi)	Compressor (HP)
<b>Type G &amp; AT-3180</b>	1/4"	3/8"	2	90	1
<b>7032</b>	1/4"	3/8"	4	90	1
<b>7033</b>	1/4"	3/8"	5	90	1.5
<b>7033L</b>	1/4"	3/8"	5	90	1.5
<b>7034</b>	1/4"	3/8"	5	90	1.5
<b>7136</b>	1/4"	3/8"	5	90	1.5



## SUPER PRECISION AIR GRINDERS

Top quality air tools for high precision work.

NSP601				
Speed	Weight	Air Consumption	Drive Air Pressure	Hose Length
60,000 rpm	165 kg	160NL/min.	4~6kg/cm2	1.5m
Std.Eqpt.	3mm collet, 1 grinding stone with axis, 1 set wrenches			
Very Strong, excellent value, quiet and high torque				

NSP-601	
	✓
ORDER REF - NSKNSP-601	



NA45-230				
Speed	Weight	Air Consumption	Drive Air Pressure	Hose Length
23,000 rpm	190 kg	160NL/min.	4~6kg/cm2	1.5m
Std.Eqpt.	3mm collet, 1 special grinding stone axis, 1 Topcut stone, 1 rubber pad, 8 self-adhesive discs, 1 set spanners			
	All Topcut stones are available			
Use as 45° air tool, very powerful with high torque				

NA45-230	
	✓
ORDER REF - NSKNA45-230	



NA90-230				
Speed	Weight	Air Consumption	Drive Air Pressure	Hose Length
23,000 rpm	190 kg	160NL/min.	4~6kg/cm2	1.5m
Std.Eqpt.	3mm collet, 1 special grinding stone axis, 1 Topcut stone, 1 rubber pad, 8 self-adhesive discs, 1 set spanners			
	All Topcut stones are available			
Use as 90° air tool, high torque for use with velcro or self-adhesive discs & grinding wheels				

NA90-230	
	✓
ORDER REF - NSKNA90-230	



NA45-400				
Speed	Weight	Air Consumption	Drive Air Pressure	Hose Length
40,000 rpm	210 kg	160NL/min.	4~6kg/cm2	1.5m
Std.Eqpt.	3mm collet, 1 grinding stone with axis, 1 set wrenches			
Use as 45° air tool, very fast for use with mounted points				

NA45-400	
	✓
ORDER REF - NSKNA45-400	



## DG65

### HEAVY DUTY RIGHT ANGLE DIE GRINDER

Better quality right angle die grinder.

- 19,000 RPM at 90 psi
- Vibration levels - less than 2.5m squared
- 6mm collet
- 0.5 hp

If you currently use the Puma right angle die grinder this tool will be of interest. It is better quality and higher power

SECO R/A DIE GRINDER	
DG65	✓
ORDER REF - SECO-DG65	





**NSK ROTUS PNEUMATIC SYSTEM**

- One of the only options available for complete flexibility in an air system.
- Similar to the Eneska 3-2 it forms a modular system with interchangeable handpieces
- For an economical and simple system where finer handpieces are necessary.
- Unusually for an air system comes complete with a foot pedal control



NSK ROTUS SYSTEM	
STANDARD SET	✓
ORDER REF - NSKROTUS	

**IM-301 AIR MOTOR**  
3,000-30,000 RPM



**ALL ENESKA 3-2 HANDPIECES**

Please call for more information.



**OTHER HANDPIECES**



**TOOLS & EQUIPMENT**

## AIR FILTERS & REGULATORS

A must for the long life and efficient running of high speed grinders.  
Precision high speed die grinders require dry/clean and lubricated air to enhance the life of your tool and prevent erosion.

### SA-2001 FILTER/REGULATOR LUBRICATOR

This air filter is ideal for the **PUMA** and **TURBO LAPPER** range of Air Tools

A daily check should be carried out to ensure water container is empty and the lubricator is topped up with tool oil.



SA-2001



ORDER REF - AIRSPSA-2001

### NORGREN BL72-201G

High quality air filter / regulator  
Has a finer mist and particle filter  
Keeps your tools cleaner so giving longer life and less down time.



NORGREN BL72-201G



ORDER REF - AIRFILTERREG

### NSK AIRLINE HI207F

Airline only for the Rotus System



AL-H1207F



ORDER REF - NSKALH1207F

### NSK AIRLINE KIT AL-H1206

Connect to the air line for steady air flow with automatic lubrication of the air tool.  
Used with the **NSK Impulse Series air grinders**.  
(See Page 158)

This unit can be wall mounted or carried between jobs using the integral handle



AL-H1206



ORDER REF - NSKALH1206

We supply High grade and Medium grade airline/tool oil for all pneumatic tools



### DIPROFIL MINI FILING MACHINE

Lightweight and a complete ergonomic design, results in more effective finishing and polishing work, especially in narrow and confined spaces.

**FITS ONTO MICROMOTORS AND FLEXIBLE SHAFT MACHINES**

#### TECHNICAL INFORMATION

**Tool Holder :** max. diameter 3.5 mm  
**Stroke Length :** 0.5 or 1.0 and 1.5mm  
**Speed :** max. 10,000 rpm  
**Dimensions :** diameter 24 mm  
**Weight :** 120g  
**Noise :** <70dB(A) at 7000 rpm

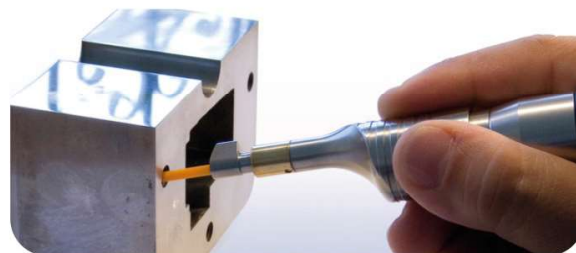

DIPROFIL MINI FILING MACHINE	
FMR MINI FILER c/w key & lubricating oil (Optional stroke 0.5 or 1.0 and 1.5mm)	✓
ORDER REF - DIPROFILFMR	

#### ORDERING INFORMATION:

Each available in 5 (0.5mm Stroke length)  
 10 (1.0mm Stroke Length) or 15 (1.5mm Stroke Length)

**FMR/N5 or N10 or N15** - for connection to Diprofil, NSK & Eneska motors 4:1 & 3:2

**FMR/G5 or G10 or G15** - for connection to Urawa, Gesswein & Argofile micromotors

**FMR/B5 or B10 or B15** - for connection to Ball-Joint flexible shafts

**FMR/S5 or S10 or S15** - for connection to Slip-Joint flexible shafts

### FOR FLEXIBLE SHAFTS DIPROFIL FPK/R

#### FPK/R SPECIFICATION

**TOOL HOLDER-** 2-6.4mm Ø  
**STROKE** - 0-6 mm  
**SPEED** - Max. 8,000 strokes/min  
 5,000 - 6,000 recommended  
**TOOL RECEPTACLE** - Ø 2 - 6.4mm  
**DRIVE SOURCE** - Flexible Shaft/Slip Joint



DIPROFIL FOR FLEXSHAFTS	
FPK/R	✓
ORDER REF - DIPROFILFPK/R	

TOOLS & EQUIPMENT

### AIR DRIVEN DIPROFIL FPL/R

#### FPL/R SPECIFICATION

**TOOL HOLDER** - Max. 3.5mm dia.  
**STROKE** - 0-6mm continuously adjustable  
**SPEED** - Max. 8,000 strokes/min  
 5,000 - 6,000 recommended  
**LUBRICATION** - continuously by oil mist  
**DRIVE SOURCE** - Air Driven  
**TOOL SUPPORT** - Ø 2 - 6.4mm  
**AIR PRESSURE** - 4 bar, Air consumption 65 l/min at 8,000 strokes/min



DIPROFIL AIR DRIVEN	
FPL/R	✓
ORDER REF - DIPROFILFPL/R	

## AIR DRIVEN DIPROFIL FXL/N



**New Technology**  
- Counterweight  
reduces the risk of  
white finger (also  
available on flexshaft,  
micromotor versions)

### FXL/N SPECIFICATION

For use with Air Source

**STROKE LENGTH** - 0 – 6 mm,  
continuously adjustable

**NO. OF STROKES MAX.** - 7,000 strokes/min  
(5-6,000 strokes/min recommended)

**TOOL SUPPORT** - Ø 2 - 6.4mm

**AIR PRESSURE** - 4 bar, Air consumption  
60 l/min at 7,000 strokes/min

**LUBRICATION** - continuously by oil mist

### DIPROFIL AIR DRIVEN

Di-Pro FXD



ORDER REF - DIPROFIL-DO-PROFXD

### DIPROFIL ACCESSORIES AVAILABLE



### STRAIGHT TURBO LAPPER

0.3mm, 0.7mm or  
3mm stroke length

### AIR (TURBO) LAPPERS

Straight and Swing Lappers

**STRAIGHT LAPPER:** 35,000 Strokes a minute.

**Stroke Lengths :** 0.3mm, 0.7mm or 3mm

**SWING LAPPER:** 15,000 Strokes a minute.

**Stroke Lengths :** 0.7mm

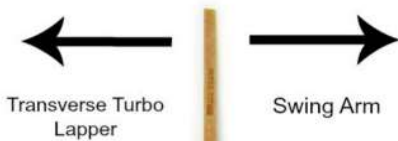

Both options come complete with all the  
holders to take 1/4 x 1/8" stones, 1x4 ,1x6 or  
3mm dia. ceramic stones

### SWING - TRANSVERSE TURBO LAPPER

0.7mm Stroke Length



They are low noise, low vibration but have a  
strong pulse. One of the best tools on the market  
for doing slots and ribs.

### TURBO LAPPER

TYPE	STROKE LENGTH	
SWING (TRANSVERSE)	0.7MM	
STRAIGHT	0.3MM, 0.7MM OR 3MM	✓

ORDER REF - AIRLAPPER



## HIGHER SPEC PENCIL GRINDER GP-380

Better quality pencil grinder with sturdy steel housing.

- 80,000RPM
- 3mm collet

PENCIL GRINDER	
GP-380	✓
ORDER REF - AIR-PENCIL-GP380	



# DOTCO®

Premium quality air tools for heavy duty work. Long lasting - well made tools.

All tools (except pencil grinder, type A) supplied with a 'lock off' lever. This minimises the risk of accidental start. Easy one hand operation.



**TYPE F  
RIGHT ANGLE**

All tools come with a range of collets



**TYPE A  
PENCIL GRINDER**



**TYPE C  
5" EXTENDED  
MEDIUM DUTY**



**TYPE E  
5" EXTENDED  
HEAVY DUTY**



**TYPE H  
TURBINE  
(FAST SPEED)**

TOOLS &  
EQUIPMENT

DOTCO AIR TOOLS					
Type	Speed	Capacity	Motor		
Type A - Pencil Grinder	60000	1/4"	0.1HP	✓	
Type H - Turbine	100000	3/16"	0.06 HP	✓	
Type C - 5" Extended Medium Duty	28000	1/2" or 1"	0.3hp	✓	
Type E - 5" Extended Heavy Duty	22000	1", 1.1/2"	0.9HP	✓	
Type F - Right Angle	20000	1/2" 1"	0.4HP	✓	

## AIR FILING MACHINES

Our new air filing machines have very little vibration. They are excellent for deburring, chamfering, grinding and polishing

**SHL-40** For deburring of die cast aluminium products and machined parts.  
Stroke Speed - 9,000  
Stroke Length - 4mm  
File Shank Size - 3mm



## MAH-16

For fine reciprocating, especially on precision parts.  
Stroke Speed - 11,000  
Stroke Length - 2.2mm  
File Shank Size - 3mm

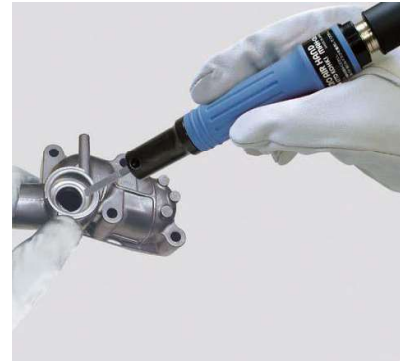

BIAX DEBURRING TOOLS				
MODEL	BEW309	BEW605	BE309	BE805
Valve	lever	lever	push-start	push-start
Rotational speed (min.-1)	900	500	900	500
Performance (watt)	20	80	20	80
Max. tool mounting (mm)	3 Skt.	6	3	8
Max. bore hole dia. (mm)	10	25	6	25
Counterbore dia. (mm)	6\10	15\25	6	15\25
Collet included	x	x	ZG5 3mm	ZG7 8mm
	✓	✓	✓	✓

ORDER REF - BIAX-(MODEL)



BE309



BEW309



BE805



BEW605

## PNEUMATIC STRAIGHT GRINDER

SRD3-55/2 - 55,000RPM  
Rear Exhaust – Twist Valve on/off  
100 Watt  
Includes 1.5 metre Air Hose & 1 metre Exhaust Hose  
Complete with 3mm



TOOLS & EQUIPMENT

**BEW309, BEW605, BEW606** - This angular designed machine makes possible the deburring of bore holes in difficult to reach areas, eg slanted bore holes that need to be deburred from the inside.

**BE309, BE805** - The straight drilling deburrer is available in two different sizes for various bore holes. The push-start feature eases handling. It is also possible to regulate the rotational speed. To improve handling the attached hoop can be used to hang the machine on a spring pulley.

## BIAX QUICK-RELEASE 'ONE HAND' COUPLING

(311-366-706) Threaded connector. Type 6  
N 3667 – male thread R 1/4"



## BIAX COLLETS

Various collets available:  
1mm, 1.5mm, 2mm,  
3mm, 3/32" & 1/8"





## ENESKARECOAT 85

The new Eneska carbide coating unit. A carbide coating is applied by burning a tungsten Carbide electrode at 280 deg C. which generates a surface hardness of 82 HR 30N.

This system has higher voltage (54 volts) and offers stronger and better coating than ever. As well as an optional foot control the ergo handpiece has an operating switch giving much greater control of the plating process. More software development has taken place allowing auto tuning which gives automatic balancing of the ignition timing.

Overall this new unit with higher voltage allows for, thicker carbide layers, faster application, better surface finish and reduction in handpiece vibration.



TUNGSTEN ELECTRODES	
ROUND	1 Ø X 50
ROUND	1.3 Ø X 50
ROUND	1.8 Ø X 50
ROUND	2.3 Ø X 50
SQUARE	1.1 Ø X 50
SQUARE	1.6 Ø X 50
SQUARE	2.1 Ø X 50
THREE SQUARE	2.1 Ø X 50

Micro-section magnified 250 times

uncoated                      coated



Tungsten carbide layer up to 82 HR 30N hardness  
Steel layer up to HR 30N rehardened  
Base material (steel) unaltered

Set of tungsten carbide electrodes (24 pieces)  
3 tungsten carbide electrodes, per shape and size.

## EW COMBI KIT INCLUDES;

- The control unit
- Wand assembly to operate brush
- Wand assembly to operate paddle and sock
- Earth lead with crocodile clip
- Mains lead – 110v or 240v
- 1 x pack of EW-500 pads (pack contains 20 pads)
- Stainless steel insert (paddle)
- Long life brush (2 x supplied)
- 0.5 litre of Electro-Wand solution
- Spill proof reservoir for solution

EW-Combi	
Complete kit	✓
ORDER REF - WELDCLEANINGMACHINE	



## ENESKAlaser 1000

The ENESKAlaser is particularly suitable as a mobile workstation, above all for smaller repairs and joining processes, with excellent results. The entire control of the laser system is performed by means of a convenient touchscreen interface. Open laser welding systems can be operated using a joystick in combination with the 3-axis welding table pictured right. The laser output, pulse length, repetition rate and beam diameter can be conveniently adjusted on the display. Furthermore, it is possible to follow the welding process via the eyepieces, the touchscreen or an external monitor. The software has a program management, under which various machining parameters can be stored (over 100 memory locations).

## 3-AXIS WELDING TABLE

X-Y-Z travel unit for precise positioning of the workpieces and for receiving the open laser devices ENESKAlaser 750/1000. The 3-axis table is equipped with 3 sturdy castors and is therefore mobile. Furthermore, the open ENESKAlaser together with the 3-axis table forms an optimum technical unit.



ENESKAlaser1000	
ENESKAlaser	✓
ORDER REF - 4910800	
3-AXIS WELDING TABLE	✓
ORDER REF - 4910501	



## ENESKAlaser 1500 MOBILE

The laser welding system is suitable for repairing medium and large-size moulds/workpieces. Ideal for mould shops. Simple and functional. Allows a wide range of repairs to be carried out directly on site. The extension arm, pivotable through 180° makes alignment with the workpiece very easy and flexible. The high quality 10 x stereo microscope with integrated safety filters and a very rapid, eye-friendly LCD shutter provides a perfect view and safety for the operator. The welding head is equipped with motorised beam diameter adjustment, dimmable LED workpiece lighting and a flexibly adjustable gas supply. A generously dimensioned colour touchscreen for configuring all the necessary laser parameters simplifies operation and control.

ENESKAlaser1500 MOBILE	
ENESKAlaser 1500	✓
ORDER REF - 4910880	



**ENESKAmarker 300**

Laser markings generated with an ENESKAmarker 300 guarantee optimally durable component identifications. The markings are created quickly without the application of force or contact. This makes it easy to mark thin-walled, ground and finished components. The sealable, screened working area of the ENESKAmarker 300 ensures safe operation. The graphic user interface makes the operator software very easy for users to handle. Furthermore, electrical height adjustment on the front of the ENESKAmarker makes it easy to adjust the laser head to bring a wide range of workpieces into the correct focus. In combination with the laser preview function, the projection process enables every type of marking to be created on a component. That ensures reliable production and eliminates a reject rate. For example, the markings may be QR codes or images.

The marking device can be used on many different materials, such as metal and some plastics.



**ENESKAmarker 300**  
✓  
**ORDER REF - 4920800**



**ENESKAimpulse 230**

With the new ENESKAimpulse 230 welding system, joke combines the accuracy and precision of repair welding with the advantages of state-of-the-art control technology and user-oriented ergonomics.

Intuitive control logic:

A neatly structured control unit with a bright colour display and a central rotary pushbutton make it easy to select the appropriate functions. Quick selection buttons let you retrieve your own or built-in favourite settings even faster at the touch of a button. It couldn't be quicker or more effective!

Presets:

Everything is backed by the experience and competence gained through decades of user support. Every task needs the right device settings - the ENESKAimpulse guides the user through the whole welding process and automatically selects the best settings for the respective selected welding tasks.

- The ENESKAimpulse 230 has a powerful output of max. 230 A
- Versatile and mobile use - robust yet light: only 7.3 kg
- Compatible with joke MultiSpot3 accessories
- Hand torch connections compatible with Multispot and Easyspot.
- This means that all gas-cooled hand torches from the joke range can be used.

**ENESKAimpulse 230**  
✓  
**ORDER REF - 4906230**



## WELDING WIRES

Extensive range of laser and TIG welding wires in spool and straight length. 0.1mm up to 1.6mm (larger diameters on request)

## NEW RANGE

More types, more diameters and better prices

### P20: FILL W-10 OR SLIGHTLY HARDER H-55- EXCELLENT FOR EDGE WEAR

**FILL W-10** available in .2,.3,.4,.5,.6 in reels .2,.3,.4,.5,.6,1.0,1.2,1.6,2.4 in rods

**FILL H-55** available in .2,.3,.4,.5,.6 in reels .2,.3,.4,.5,.6,.8,1.0,1.2,1.6 2.4 in rods

### H13: FILL M-40 OR HARDER W-22 OR VERY HARD M-45

**FILL M-40** available in .2,.3,.4,.5,.6 in reels .2,.3,.4,.5,.6,.8,1.0,1.2,1.6, in rods

**FILL W-22** available in .2,.3,.4,.5,.6 in reels .2,.3,.4,.5,.6,.8,1.0,1.2,1.6 in rods

### 1.2767: FILL W-25 OR FILL H-55 EXCELLENT FOR EDGE WEAR

**FILL W-25** available in .2,.3,.4,.5,.6 in reels .2,.3,.4,.5,.6,.8,1.0,1.2,1.6 in rods

**FILL H-55** available in .2,.3,.4,.5,.6 in reels .2,.3,.4,.5,.6,.8,1.0,1.2,1.6,2.4 in rods

### D2: FILL W-22 OR SLIGHTLY HARDER FILL H-65 OR FILL H-55

**FILL W-22** available in .2,.3,.4,.5,.6 in reels .2,.3,.4,.5,.6,.8,1.0,1.2,1.6 in rods

**FILL H-65** available in .2,.3,.4,.5,.6 in reels .2,.3,.4,.5,.6,.8,1.0,1.2,1.6 in rods

**FILL H-55** available in .2,.3,.4,.5,.6 in reels .2,.3,.4,.5,.6,.8,1.0,1.2,1.6,2.4 in rods

### ALUMINIUM: FILL A-50 OR HARDER A-70

**FILL A-50** available in .3,.4,.5,.6 in reels .3,.4,.5,.6,1.0,1.6,2.4 in rods

**FILL A-70** available in .3,.4,.5,.6 in reels .3,.4,.5,.6,1.0,1.6,2.4 in rods

### STAVAX: FILL M-50

**FILL M-50** available in .2,.3,.4,.5,.6 in reels .2,.3,.4,.5,.6,1.2 in rods

### COPPER, BRONZE, ALLOYS: FILL G-10

**FILL G-10** available in .2,.3,.4,.5,.6 in reels .3,.4,.5,.6,1.0,1.2,1.6,2.4 in rods

### TITANIUM: FILL S-90

**FILL S-90** available in .3, .5mm reels



**MASS FINISHING**

- P168 - 171 - VIBRO FINISHING
- P172 - 173 - SHOT BLASTING
- P174 - MAGNETIC DEBURRING
- P175 - ULTRASONIC TANKS
- P176 - SURFACE TESTING



With over 30 years experience in Mass Finishing we offer both the right machine and media for the job, whilst also offering the on going support from our experienced team, backed up by the Rosler team in both the UK and Germany, "why settle for anything less".

Case studies have shown us that as customers look for consistency and quality, they are all asking questions about mass vibro finishing, and with the technology now we are able to offer finished parts in batch sizes of 100 within in 45 minutes deburred and polished.



**TOOLS & EQUIPMENT**



MINI BOWLS			
MODELS	AV25	AV40	AV75
Outside dia.	355mm	430mm	530mm
Bowl depth	152mm	175mm	240mm
Capacity	5 litre	9 litre	23 litre
Work load	X	15 kg	30 kg
	✓	✓	✓

ORDER REF - AV(25, 40 or 75)

## MINI BOWLS FOR FINISHING & POLISHING

- Small rumbling bowls are a very inexpensive way of mass finishing. They are capable of working small to moderate batches of components. They can be used for deburring, polishing, texturing, machine line removal on any metal or plastic part. Acoustic lid effectively reduces noise to make this machine highly suitable for small factory space.

Available in 3 sizes.

## LIQUID COMPOUND

The foundation of the modern surface finishing process.

- It removes contaminants such as metal and/or media fines from the process
- Keeps components and media clean
- Ensures media performs properly

These are the two most popular types



### FC120 (Green)

Universal cleaning & polishing - best for polishing especially with plastic media.

### FC115 (Pink)

Corrosion protection for ferrous metals- Ideal with ceramic media for grinding

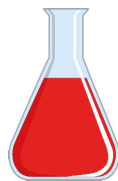

VIBRO LIQUID			
	1 Litre	5 Litre	25 Litre
FC120	✓	✓	✓
FC115	✓	✓	✓

ORDER REF - FC...

These small bowls are very popular for small scale parts particularly jewellery, aerospace parts, motorbike & car parts, laser cut parts etc

- Small batch sizes
- Delicate processing with less aggressive media, through to heavy duty deburring
- Ideal for cleaning up castings and rust removal
- Simple to use and time efficient
- Speed up production with an automated system
- Dry polishing processes for mirror finishing



## CHOOSING ROSLER MEDIA

**MATERIAL** - Ceramic, Porcelain, Plastic or Walnut Shell & Maize

- **Ceramic** media offers more cut, normally used for deburring and cleaning metals. We also offer a pre-polishing media which is ideal for flattening metal prior to polishing. It is often less expensive compared with plastic media. Suited to harder metals such as steel.
- **Plastic** media is more suitable for aluminium and softer materials. The characteristics are more variable than ceramic. Smoother finishes can be achieved.
- **Porcelain Pins** can be used for effective polishing, ideal for any metal.
- **Dry Organic Media** is used for polishing, often it is impregnated. (Walnut shell & Maize)





**We are running trials for customers everyday.**

RÖSLER - Specialist in surface technology, also providing total finishing solutions, for mass finishing.

Please Call us for more details, alternatively you can visit our website to see the range of media we offer.



**RÖSLER**<sup>®</sup>  
*finding a better way ...*

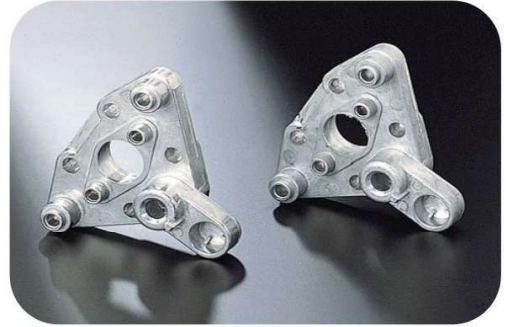
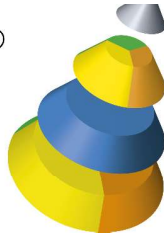

Rosler mass finishing machines offer an ideal solution to automation of processes. Deburring and creating a uniform surface finish on any metal or plastic component



**HIGH ENERGY FKS**  
Centrifugal Machines



Vibro bowls available in a range of sizes with or without media/ component separation

**WASTE WATER CENTRIFUGAL SYSTEMS**  
Re-circulation systems available



**WHEEL POLISHING MACHINE**  
Ideal for both cut and polish



MASS  
FINISHING



**DRAG FINISHING MACHINE**

The most powerful mass finishing process.  
Very popular for medical implants



**TUMBLE BELT SHOT BLASTER**

Particularly good for castings



**CENTRIFUGAL MACHINES**

With a two step process



Send us your samples for polishing/deburring  
OR CALL FOR A QUOTE TODAY  
See how cost effective this can be..  
01722 711988

We have a Rosler demonstration area with a range of Rosler Eco machines in a variety of sizes to suit a spectrum of production volumes.

Please call us to make an appointment to visit





**CABINET 50**

**CABINET 25**

**CABINET 10**



## BLAST MEDIA/AIR WASH GUN

Trigger operated blast gun c/w tungsten carbide nozzle. Option of 3 nozzle sizes 4mm, 6mm, 8mm. Media flow "Off" facility gives operator an air wash facility.

## INTEGRAL EXTRACTION \*

Efficient extraction is the key to successful blasting etc. Integral extraction eliminates trunking and being compact requires less floor space.

## EXTERNAL LIGHTING

Ensures maximum visibility, enclosed in its own housing and protected by the viewing window, minimises any possible accidental damage to the light.

## MEDIA DOOR RELEASE

Simple and extremely fast media change ensuring minimum downtime.

## SIDE DOOR ENTRY

Large side door entry allowing easy loading of large components.

## POWDER COATING

All machines are degreased and powder coated for maximum life and durability.

\* Not included in Cabinet 10



Accessories available – details on request spare guns & nozzles, acetate sheets, shotblast gauntlets

## ABRASIVE BLASTING MACHINES

For surface texturing & cleaning

**CABINET 10**

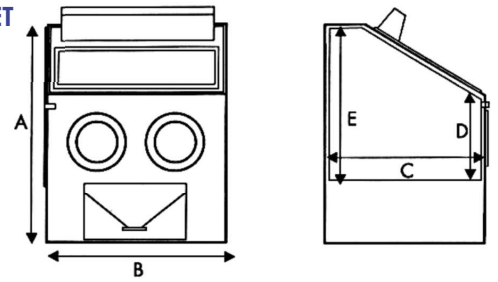

**CABINET 25**

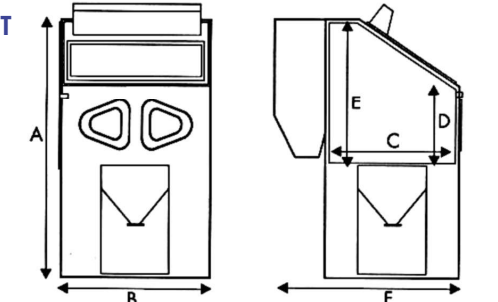

**CABINET 50**

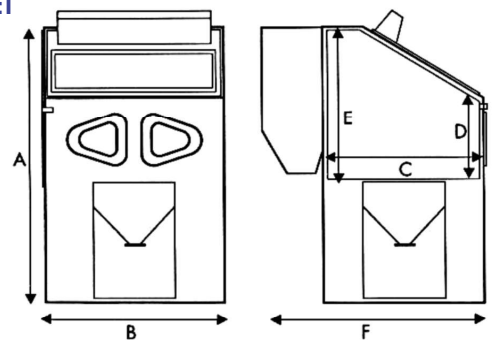

CABINET 10	
Dimensions	
A	820
B	770
C	540
D	300
E	520
	✓
ORDER REF - BLASTCAB10	

CABINET 25	
Dimensions	
A	1680
B	815
C	610
D	460
E	760
F	915
	✓
ORDER REF - BLASTCAB25	

CABINET 50	
Dimensions	
A	1680
B	915
C	760
D	455
E	770
F	1070
	✓
ORDER REF - BLASTCAB50	



## PVC SHOT BLASTING GAUNTLETS

See glove page 184



**SHOT BLASTING MEDIA**

For use with abrasive blasting machines.

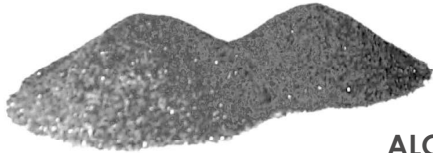

**ALOXITE GRIT**  
Please ask for more details  
Sold Per 25kg

ALOXITE GRIT	
Per 25 kg	
25kg	✓
50-100kg	✓
125-225kg	✓
250kg +	✓
ORDER REF - ALOXITE	

ALOXITE GRIT	
Grades Available	
12, 16, 24, 36, 46,	
60, 90, 100, 120,	
150, 180, 240, 320	

**PLASTIC MEDIA FOR WET OR DRY BLASTING**

**UREA** - most commonly used, middle hardness of the thermoset plastics. Random/Blocky/Angular shape.

**MELAMINE** - most aggressive and hardest.

**ACRYLIC** - least aggressive - ideal for delicate component cleaning. Does not shatter on impact, but wears down.

**POLYCARBONATE** - used for cryogenic deflashing or deburring of rubber or aluminium diecast products.



**GLASS BEADS**  
Leaves a shiny, bright finish.  
Sold Per 25kg

GLASS BEADS	
Per 25 kg	
25kg	✓
50-100kg	✓
125-225kg	✓
250kg +	✓
ORDER REF - GLASSBEAD	

GLASS BEADS	
Grades Available	
0/44 (Fine)	
50/100	
100/150	
150/300	
300/400	
400/600	



**JOKE SMALL BLASTING UNIT**

Bench top unit for really intricate blasting. Nozzles are 1.0mm and 1.2mm diameter. Cabinet is 550 x 520 x 400mm.

**JOKE OPEN MICRO FINE BLASTING UNIT**

Open system allowing detailed shot blasting to be done on a large component. Nozzle is 1.2mm diameter.



**ROSLER AUTOMATED SHOTBLASTING**

Rosler offers an impressive range of shotblasting units both manual and automated, suitable for all industries. Take out the time consuming hand processes and achieve a consistent finish on batches.

This particular unit features a rotating basket with adjustable shot blasting nozzles directed at the basket. A fully automated system.



INTRODUCING .....

the **SPINner**

## A NEW CONCEPT IN DEBURRING AND FINISHING

- A magnetic deburring and polishing machine for small precision parts in medical, electronics and aerospace industries.
- Eliminates costly and timely hand deburring processes in minutes.
- Rotating and magnetic discs under the surface of the machine activate the media where the components are immersed in a processing liquid.



- Eliminates the inconsistency of hand deburring.
- Creates a uniformity to the surface of the components in a single cost-effective operation.

Non ferrous metals including aluminium, brass, stainless steel and titanium can be deburred and fine finished, however, most steels, certain plastics and precious metals can also be processed without any effect on tolerances or damage to delicate areas and as a result will achieve a bright smooth finish.

- The gentle process means that it does not degrade corners or edges of components
- Ideal for use on external and internal threads, slots, chamfers and intersecting holes
- The shape and size of the media means it will not lodge or jam in or around the features of the component.
- The machines can be programmed at a slow speed for deburring or sped up for finishing and polishing. Processes can be tweaked to suit individual requirements.



MASS  
FINISHING

## ULTRASONIC CLEANERS

Ultrasound means vibration generated by frequencies inaudible to the human ear (above 20 kHz). In liquids this causes small bubbles which break within a fraction of a second. This imploding results in high liquid movement which rapidly removes contaminations from the surface.

All types of unit are made from stainless steel and have the added benefit of having heaters and timers.

### MAIN FEATURES

- Industrial grade cleaners
- Built in heater
- Stainless Steel basket and lid included
- Degas feature
- Timer (0-60mins)
- Ultra quiet operation
- Stainless Steel tank
- Full CE and RoHS approval
- 24 month warranty

**Multiple Usages: Jewellery, Dental, Optics, Laboratory, Watches, Electronic, Small Machine Parts**



### SONIC 6 CLEANER

General purpose cleaner, added to the water for degreasing.



SONIC 6 CLEANER	
5 Litres	✓
ORDER REF - CLEAN	

## JOKE RANGE OF ULTRASONIC CLEANERS

We can offer a full range of Joke ultrasonic cleaners ranging in size internally from 190x85x60 to 700x600x500 (up to 200 Litres)

**ELMASONIC** - The powerful and versatile Elmasonic Select ultrasonic cleaning devices are equipped with a frequency of 37 kHz, 5 ultrasonic modes and the possibility to save up to 4 cleaning programmes. Elmasonic Select is available with tank volumes from 3 to 90 litres.

**THE ECO-CLEAN SERIES** are particularly durable. The sweep function ensures optimum sound distribution in the cleaning bath by electronic oscillation of the sound field. Powerclean offers an aggressive cleaning mode while switching to Softclean allows gentle action on more sensitive and delicate components.

The **MULTI-FREQUENCY** units offer complete control over the cleaning process but also allows both sweep and degassing modes. Degassing is required to get the optimum cleaning effect, as if air is on the surface of the parts the bubbles become too big and rather than implode, escape from the liquid.

In addition, industrial units can be custom manufactured to practically any shape and dimensions. Larger industrial units are powered by using ultrasonic submersible transducers and external generators, which are welded stainless steel units with braided stainless steel hoses connecting power to the generators.

### MOORE & WRIGHT SURFACE ROUGHNESS TESTER - MTR110

The Surfmatic MTR110 is a pocket sized surface roughness measuring instrument ideally suited to rapid on-the-spot surface measurements. Conforms to ISO Class 3.

Features:

- Back-light LCD
- Dynamic Test Display: progress of cut-off length during testing
- Li-ion rechargeable batteries
- Protection slide on pick-up
- Auto-off after 90 seconds
- Pocket-size and economically priced
- Both Ra and Rz parameters in one instrument
- Features external calibration specimen
- Large measuring range suitable for most materials
- Piezo-electric pick-up stylus for external surfaces
- Includes steel test piece
- Includes charger unit
- Measurements of shafts above 40mm diameter using the Vee groove in base



**Please contact us for price and availability**

### SURFTEST SJ-210

This is a portable measuring instrument that allows you to easily and accurately measure surface roughness.

#### THE SURFTEST SJ-210 OFFERS YOU THE FOLLOWING BENEFITS:

Skid system gives you user friendly and intuitive menu navigation.

It works independently of mains power, allowing you to make on-site measurements.

The 6.0 cm [2.4"] colour graphic, back-lit LCD gives you excellent readability.

It performs roughness analyses conform to various international standards (EN ISO, VDA, ANSI, JIS) and customized settings.

Different drivers expanding the range of applications.

Calculation results, assessed profiles, bearing and amplitude curves can be displayed.

Support of 21 languages.

Operation by keys on the front and under the sliding cover.







## SAFETY & INSPECTION

- P178 -179 - LIGHTING
- P180 - OPTIVISORS
- P181 - 182 - EXTRACTION
- P182 - 183 - WORKSHOP EQUIPMENT
- P184 - PPE

With safety always being top of our minds we have aligned ourselves with some of the top manufacturers in the UK to offer you a range of PPE to keep you safe in the work place.

Also in this section you will find all of the equipment needed to light up your inspection area and magnify the work piece.



## MAGNIFIER FLUORESCENT BENCH LIGHTS

Combined 5" diameter magnifier lens and circular fluorescent tubes, gives even, shadow-free light. Creating a daylight effect without reflection. Excellent for colour matching, electronic ballast built into arm. Accept 22, 28 and 30 watt fluorescent tubes. 220 volt supplied, complete with 1.8 metre cable and 22 watt tube. Easy positioning and adjustment. Optional bench clamp.



### MODEL M1 - MEDIUM ARM

525mm arm reach. Fully adjustable for rotational direction and reach.

<b>M1 LIGHT LED</b>	
	✓
<b>ORDER REF - LIGHT-M..</b>	



### MODEL M3 - LONG ARM

1230mm arm reach. Fully adjustable for rotational direction and reach.

<b>M3 LIGHT LED</b>	
	✓
<b>ORDER REF - LIGHT-M..</b>	



### MODEL M4 - SHORT ARM

Constructed with a wide, stable base making it easily portable. Fully adjustable, easily suited for inspection lighting purposes.

<b>M4 LIGHT FLURO</b>	
	✓
<b>ORDER REF - LIGHT-M..</b>	



## FLEXIBLE INSPECTION LIGHT LED

This 370mm long and 6.4mm Diameter flexible LED light is perfect for lighting-up hard to reach areas. It can be immersed in water, gasoline and oil. Perfect for engines, tools, machinery etc.

<b>FLEXIBLE INSPECTION LIGHT</b>	
<b>Length of Flexy</b>	
<b>370mm long Flexy</b>	✓
<b>REF - LIGHT-FLEXINSPEC-2PL</b>	



<b>LIGHTING ACCESSORIES</b>	
<b>Portable Bench Clamp</b>	✓
<b>Replacement Daylight Tube</b>	✓
<b>ORDER REF - LIGHT</b>	

## JOKE LOUPE WITH LED LIGHTS

6 LED's ensure shadow-free illumination. The 21mm lens system consists of 3 glass lenses which guarantee colour error-corrected and distortion-free images. The LED's are supplied by 3 x LR927 button cell batteries.



<b>LED LOUPE</b>	
	✓
<b>ORDER REF - JOKE-0200538</b>	

**QUARTZ HALOGEN LAMPS**

Glare-free bench lamps, concentrates light onto work piece through the reflection lens built into the luminaire lamp head. Can be fitted to existing low power supply- 24 volt only. Models fitted with transformer connect direct to standard 220-240 volt supply. Complete with 1.8 metre cable

Easily bolted to work bench– optional surface bench or side clamp for portable use, a movable side bench clamp, strong magnetic base or metal table base

**Please state voltage/watts required**

**DAY LIGHT LAMP D35500**

- 51cm (20") wide shade gives even spread of light over a large area
- Colour temperature 6,000°Kelvin
- CRI 80
- 2 step dimmer
- Head joint holds multi-positions allowing to direct the light where it is needed
- Long reach arm 108cm (42.5") with internal springs



DAY LIGHT LAMP	
<b>D35500</b>	✓
REF - LIGHT-DAYLIGHT	



MODEL H1T LED	
<b>H1T</b>	✓
ORDER REF - LIGHT-H1	

**MODEL H1 (H1T) - MEDIUM ARM**

445mm arm reach. Fully adjustable for rotational direction and reach. 240v with transformer and LED bulbs



LIGHTING ACCESSORIES	
<b>Magnetic Base</b>	✓
<b>Table Base</b>	✓
<b>Replacement Bulbs:</b>	
<b>PLEASE CONTACT US</b>	
ORDER REF - LIGHT	



MODEL H2T LED	
<b>H2T</b>	✓
ORDER REF - LIGHT-H2	

**MODEL H2T - LONG ARM**

830mm arm reach. Fully adjustable for rotational direction and reach. 240v with transformer and LED bulbs



MODEL H3 HA	
<b>H3</b>	✓
ORDER REF - LIGHT-H3	

**MODEL H3 - SHORT ARM**

H3 – Without transformer, requires 24 volt supply with 75 watt bulb, or 12 volt supply with 55 watt bulb.



MODEL H4	
<b>H4T LED</b>	✓
ORDER REF - LIGHT-H4	

**MODEL H4 (H4T) - FLEXIBLE ARM**

500mm arm reach. H4T – With transformer. Bulb power 20 watts or 35 watts.

## DONEGAN OPTIVISOR

- Lenses made from ground glass
- Adjustable head band
- Tilts up for convenience
- Light weight and comfortable
- Interchangeable lens plate



DONEGAN OPTIVISOR	
<b>COMPLETE</b>	✓
ORDER REF - OPTIVISORDA..	

## OPTILOUPE

An auxiliary lens which may be fastened either side of the Optivisor for additional magnification (up to 6 x).



OPTILOUPE	
<b>UP TO 6X MAGNIFICATION</b>	✓
OVOL	



## VISOR LIGHT

Hands Free - Clips onto the Optivisor and gives 6000 candle power- 5 to 6 hours of battery life.

VISOR LIGHT	
<b>COMPLETE VISOR LIGHT</b>	✓
<b>REPLACEMENT BULB</b>	✓
ORDER REF - OPTIVISOR-LIGHT	

## LENS PLATES

Lens plates can easily be removed and changed.



LENS PLATES	
<b>ALL MAGNIFICATIONS</b>	✓
ORDER REF - OVLPCA..	

## VISOR ONLY OV12

No lens plate included.

OV12 OPTIVISOR	
<b>WITHOUT LENS</b>	✓
ORDER REF - OPTIVISOROV-12	

Order OptiVISOR® in any of these six lens options:

OptiVISOR

As seen by normal vision

OptiV

Item No. DA-2  
Magnifies 1 1/2X  
at 20'

OptiV

Item No. DA-3  
Magnifies 1 3/4 X  
at 14'

Opti

Item No. DA-4  
Magnifies 2 x  
at 10'

Opt

Item No. DA-5  
Magnifies 2 1/2 X  
at 8'

Op

Item No. DA-7  
Magnifies 2 3/4 X  
at 6'

On

Item No. DA-10  
Magnifies 3 1/2 X  
at 4'

iV

OptiLOUPE Option  
Item No. LP1  
Monocular attachable lens, adds 2 1/2 X to all models



**BOFA EXTRACTION SYSTEMS**

High Quality **British Made** Extraction Systems

We offer the full range of Bofa fume and dust extraction systems to suit a number of industries. From very simple to highly specialised, these systems are easily tailored to meet your health and safety requirements.



BOFA DUST EXTRACTION	
<b>DUSTPRO 400</b>	✓
ORDER REF - BOFA-DP400	



**DUST EXTRACTION**

Customisable systems to suit deburring and polishing operations. Bofa offer a great range of accessories to suit your working set up.

## The ENESKApostprocess

The safest extraction posts process workstation on the market. This allows you to work with the freedom and ease of an open workbench, but with the safety to allow powder removal. Support removal and surface finishing, release of residual powders and dusts that may be respirable, carcinogenic, skin-irritant, and in some cases even explosive.

This is being sold in Europe and the States, with recent sales into F1, Abrasive Manufacturers, engineering workshops, and universities.



## Deburring box JK19

Deburring box JK 19 for connection to an extraction system

With integrated lighting, air gun and access openings with vertical blinds. Large working area with small external dimensions.

Technical data:

Dimensions (W x D x H): 600 x 400 x 300 mm

Supply voltage: 230 V, 50 Hz

Exhaust air connector: rear

Weight: 15 kg

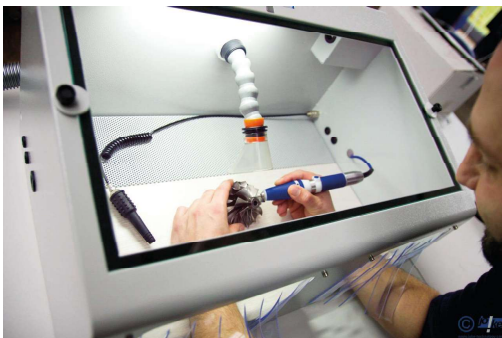

**DEBURRING BOX JK19**  
ORDER REF - 0200894

## Worktable joke Ergo-Work



**WORKTABLE JOKE ERGO-WORK**  
ORDER REF - 0200850



**METAL HOOD WITH EXTRACTION FITTING**  
ORDER REF - DUSTHOODSFLOORM.



**MAGNETIC CLAMPING BALLS**

Comfortable and ergonomic 3-dimensional working. Ideal for polishing and welding. The powerful magnetic chuck of the Magic-ball is activated using the key supplied (partial activation is also possible for positioning). Excellent quality - German made



MAGNETIC CLAMPING BALLS			
MAGNET DIMENSIONS (MM)	BALL DIMENSIONS (Ø X H) AT 0°		ORDER REF
80mm Ø	Ø 128 X 104 mm	✓	JOKE-0200323
100mm Ø	Ø 158 X 129 mm	✓	JOKE-0200324
130mm Ø	Ø 188 X 145 mm	✓	JOKE-0200325
160mm Ø	Ø 218 X 164 mm	✓	JOKE-0200326

**POSITIONER**

For flexible polishing of smaller workpieces: the ball joint can be rotated in all directions and fixed with a clamping lever. In addition, the magnet can be rotated by 360° and fixed through a clamping lever. Freely rotatable ball joint, rotation range magnet: 360°  
Magnet dimensions: Ø 125 x 48 mm  
Pivot Range: 0-55°



POSITIONER	
Positioner Joke Junior	✓
ORDER REF - JOKE-0200049	
DS 300 CLAMPING TABLE	
540 x 420 mm	✓
ORDER REF - JOKE-0200300	
ROUND MAGNETS FOR DS300	
MAGNET DIMENSIONS	
Ø 160 x 75mm	✓
ORDER REF - JOKE-0200314	

**CLAMPING TABLE**

With 300mm Ø support plate to hold different magnetic chucks. Grid holes M10 4 x 90° for mechanical clamping without magnetic chucks.

**CLAMPING TABLE DS 300**

Workpieces up to 200kg can be clamped and pivoted within a range of 0 - 100° and rotated by 360° on the turntable.

**SMALLER SIZE - ROTATING AND REVERSIBLE CLAMP 1B WITH PLASTIC JAWS**

Jaw width: 46 mm  
Clamping length: 50 mm  
Clam depth: 35 mm



ROTATING & REVERSIBLE CLAMP	
VICE 1B	
With Plastic Jaws	✓
ORDER REF - JOKE-0200002	
VICE 2B	
With Aluminium Jaws	✓
ORDER REF - JOKE-0200015	

**LARGER SIZE - ROTATING AND REVERSIBLE CLAMP 2B WITH ALUMINIUM JAWS**

Jaw width: 80 mm  
Clamping length: 100 mm  
Clamping depth: 52 mm



JUNIOR BALL JOINT VICE	
For Clamping	✓
ORDER REF - JOKE-0200055	

**JUNIOR BALL JOINT VICE**

With rippled hardened steel jaws  
Jaw width: 80mm  
Clamping length: 65mm  
Clamp depth: 50mm

**SAFETY & INSPECTION**



# PROTECTIVE CLOTHING/GLOVES



APRONS	
LEATHER APRONS	
Heavy duty, with patch	✓
ORDER REF - LEATHERAPRON-PATCH	
PVC APRONS	
Black, 48 x 36"	✓
ORDER REF - APRON	



**LEATHER APRON**  
Full chrome leather apron with front patch– heavy duty

## LATEX GLOVES

## STOCKINETTES

## COTTON/CHROME GC116

## STANDARD RIGGER

Excellent quality leather gloves



## S5 TIGER RIGGER

Reflective safety strip  
Comfort and safety  
Value and quality



## S6 HEAVY DUTY RIGGER

Deluxe quality side split red leather gauntlet with contrasting welt. Fully lined and welted with Kevlar Stitching



## LEATHER GLOVES

Double Palm



## RED PVC GAUNTLETS

High quality gauntlet offering superior resistance to chemicals, oils and greases. Smooth finish for sensitive and flexible handling.



## SHOTBLASTING GAUNTLETS

24" Rubber

GLOVES		
STOCKINETTE GLOVES		
STOCKINETTE	Per 10 Pairs	✓
COTTON/CHROME GLOVES		
GC116	Per Pair	✓
RIGGER GLOVES		
Red S6	Per Pair	✓
Standard	Per Pair	✓
Tiger S5	Per Pair	✓
LEATHER GLOVES		
Double palm	Per Pair	✓
PVC GAUNTLETS (Red)		
M606 560mm size 10	Per Pair	✓
SHOTBLASTING GAUNTLETS (Black)		
24" Rubber	Per Pair	✓
LATEX GLOVES		
Powdered latex gloves 100 per box	Per box	✓
ORDER REF - GLOVES		





**RÖSLER**<sup>®</sup>  
*finding a better way ...*

**ROSLEER VIBRATORY FINISHING MACHINERY**

We have an excellent range of Rosler Vibratory Finishing Machines available to view on site.

We also have the facility to run samples to find the best process for you.

**PLEASE CALL TO MAKE AN APPOINTMENT OR TO DISCUSS RUNNING SAMPLES**

You will receive the unique benefit of our experience in both mass finishing and hand deburring.



**HAND FINISHING ADVICE**

We offer the unique combination of experience in mass finishing and hand finishing to provide the best possible finish.



We often host demonstration days in various areas such as

- Hand Finishing
- Jewellery Finishing
- Vibratory Finishing



## YOU CAN ALSO ORDER ON THE MOLERODA ECOMMERCE WEBSITE

- It is now easier than ever to find the products you require on our website.
- Each product now has a detailed description, recommendations and some even have instruction videos.
- There is now an (optional) account feature for regular customers making it quicker to buy.
- Payments are taken either by RBS Worldpay or Paypal.

## OUR WEBSITES



**www.moleroda.com**

Search products

Browse by Industry: Power Tool Accessories, Finishing Compounds, Grinding & Polishing Tools, Machines & Equipment, Mass Finishing, All

Categories: Casting Finishing, Fabrication Industry, Jewellery Making, Mould Tool Finishing, Plastic & Non metals, Precision Engineering, 3D Printed & AM Tech, Browse All Products

**ENESKA**  
High quality micromotor systems for polishing, grinding and deburring. [More](#)



**www.polishingjewellery.co.uk**

Search

Shopping Cart £0.00

Home, Hand Tools, Maps & Mounted Accessories, Machinery, Compound, Workshop Essentials, All Products

**JEWELLERY MAKING TOOLS & EQUIPMENT**  
Manufacture and supply of tools & equipment for the jewellery making industry and hobbyists.

[Click to Shop](#)

MADE BY US, WHOLESALE PRICES, FAST DELIVERY, READY TO HELP

- Everything you need**  
We manufacture and supply everything you need for the creation and finishing of all types of jewellery.
- Jewellery Online Shop**  
Tools, consumables and equipment for the trade and hobbyists alike. Manufacturer and stockist of over 5,000 products.
- Worldwide Shipping**  
We export to over 20 countries worldwide. If you're not sure, get in touch and we'll do our best to help!

### LOOKING FOR OFFERS..

Our ebay shop is the place to find excellent kits and regular deals.

<http://stores.ebay.co.uk/polishit>



**OUR PRODUCTS CAN ALSO BE FOUND ON AMAZON**  
Simply search for 'moleroda' in the search bar



**MOLERODA FINISHING SYSTEMS LTD**  
**UNIT 5 WHADDON BUSINESS PARK**  
**SALISBURY, WILTSHIRE**  
**SP5 3HF**  
**TEL: 01722 711988**  
**FAX: 01722 711820**

## TERMS AND CONDITIONS OF SALE

1. Payment terms are strictly nett at the end of the month following the month of invoice. We reserve the right to charge interest at 3% per month on any account not paid within our terms of trading. Such interest will be calculated from the last day of payment permissible within our terms.
2. On any account not paid within our terms of trading, we reserve the right to add to the account any costs incurred by us in instructing an agent or solicitor to act on our behalf in the recovery of the account.
3. **RISK & PROPERTY:** Goods supplied by the Seller (Moleroda Finishing Systems Ltd) shall be at the Buyer's risk immediately on delivery to the Buyer or into custody on the Buyer's behalf (whichever is the sooner) and the Buyer should therefore be insured accordingly. Property in the goods supplied will only pass to the Buyer when the goods which are the subject of the contracts have been paid for in full. When payment has become due and has not been received in full by the Seller, the Seller shall have the right at his absolute and sole discretion to treat the contract as discharge and to repossess the goods supplied thereunder. In the event of the Buyer becoming insolvent or of a liquidator or receiver being appointed to administer the Buyer's affairs prior to payment in full to the Seller, the Seller shall have the right at his absolute and sole discretion, to forthwith treat the contract as discharged and to repossess the goods.
4. Any complaint as to goods supplied, work done or services rendered is to be notified to us in writing or by facsimile within seven days.
5. All orders below £25 nett will carry a surcharge of £5 to cover handling and documentation costs.
6. **PAYMENT BY CREDIT CARD (OR PAYPAL) IS ACCEPTED.**

## PRODUCT INFORMATION

1. Orders are accepted subject to the Company's Terms and Conditions of Sale, above. Whilst the Company has made every effort to ensure that details and information given in this catalogue are accurate at the time of publication, full technical specifications are not included and furthermore, the Company's policy is one of continuous improvement and the right is reserved to alter details and information as the need arises. Accordingly, the customer should check any details, information or prices they wish to rely on with the Company at the time of purchase.

The Company cannot accept liability in respect of any errors herein contained or for any loss or damage, malfunction or consequential loss arising from reliance upon this catalogue.

2. All rights reserved. No part of this publication may be reproduced or transmitted in any form or by any means, including photocopying and recording, without the written permission of Moleroda. Every reasonable care has been taken to ensure that the description of items are accurate, however, specifications may change.

THE INFORMATION CONTAINED IN THIS PUBLICATION IS OF A GENERAL NATURE AND DOES NOT COVER ALL POSSIBLE FINISHING APPLICATIONS. FOR ANY SPECIFIC INFORMATION REQUIRED, PLEASE CONTACT US.







**MOLERODA FINISHING SYSTEMS**

Manufacturers & Suppliers of Deburring & Finishing Tools

**POLISHING | FINISHING | DEBURRING | TOOLS | EQUIPMENT**

**FAST, EASY ORDERING!**

**CALL - 01722 711988**

9-5.00 MON- FRIDAY

**EMAIL - [sales@moleroda.com](mailto:sales@moleroda.com)**

SHOP ONLINE 24/7 at

**[www.moleroda.com](http://www.moleroda.com)**

**VISIT**

UNIT 5 WHADDON BUSINESS PARK,  
WHADDON, SALISBURY, WILTSHIRE. SP5 3HF