



**Pro-Watch® 4.x**

**Honeywell**

**Pro-Watch Basic Certified Installer**

**Course Manual Ver. 12**

**Sept 2013**

# Contents

- I. Accessing instructor-led class exam in Discover: ..... 4
- Pro-Watch Architecture..... 7
- Types of Pro-Watch ..... 8
- 1 Pro-Watch 4.0 Installation ..... 9
  - User Account Control ..... 9
  - IE Enhanced Security ..... 9
  - Web Client ..... 12
  - Sample Reports..... 13
- Backwards Compatibility Patch ..... 14
- Lab 1 ..... 14
  - Lab 1 – Part 1 - Install Pro-Watch 4.0. .... 14
  - Lab 1 – Part 2 – Fix Pro-Watch Server Service ..... 14
  - Lab 1 - Part 3 – Do an Immediate Backup ..... 16
- 2 - HID and License ..... 18
  - HID File..... 18
  - Install License..... 19
  - Voucher ..... 19
  - Lab 2 – Generate an HID File on the Desktop and License the software. .... 19
- 3 - Workstations ..... 20
  - 17 – Classes..... 22
  - 18 – Users ..... 26
  - 19 – Users from Roles instead of a class. .... 28
    - Lab - Users from Class..... 29
    - Lab - User Roles from Permissions ..... 29
- 4- Time Zones ..... 31
- 5 - Holidays ..... 33
  - Lab 3 – Create Time Zones and Holidays..... 33
- 6 - Site, Channel , and Panel ..... 39
  - Site ..... 40
  - Channel..... 41
  - Panel ..... 44

Lab 4 – Site, Channel, Panel.....45

Site .....45

Channel.....45

Panel .....46

7 - Logical Devices.....48

Adding a reader .....48

Adding an Output .....50

Adding an Input Point.....51

Lab – 5 Logical Devices .....52

Inputs.....53

Output .....53

8 – PW panel Options .....55

Lab 6 - Panel Options.....57

Time Zones.....57

Holidays .....57

Card Formats .....58

9 – Status and Downloading.....59

Lab – 7 Status and Downloading .....60

10 – Device Status Filtering .....61

11 – Status Groups.....62

Lab 8 – Status Groups .....63

12 – Routing Groups .....65

13 – Clearance Codes.....66

14 – Companies .....69

Lab – 9 Clearance codes and Companies.....71

Clearance Codes .....71

Companies .....73

15 – Badging .....76

Companies .....79

Company Types .....80

Linked Badge Fields .....80

Linked Null Fields.....80

Batch modify .....80

16 – Compliance Reports – See Compliance Reporting Guide for more info ....82

20 – Archiving .....90

    Lab – 10 Manual Archive .....92

21– Auto-Archive .....94

    Lab – 11 Auto-Archiving.....97

22 – Backup and Restore .....98

    Backups.....98

    LAB – 12 Backup and Restore .....101

        Backup the Database .....101

        Restore the Database .....102

Appendix.....103

    PW6000 series panel Hardware .....103

        .....109

        .....110

        .....110

    IO Boards .....111

    Jumpers and DIP switches .....111

    16 Input board .....116

    16 Output Board .....119

    Enclosers.....121



    Wiring .....122

# Honeywell Discover Online Training Class Registration

## Quick Start Guide

### I. Accessing instructor-led class exam in Discover:

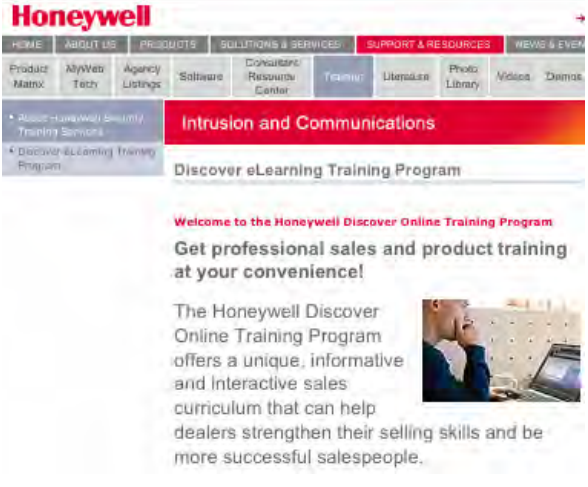
1. Log in to Discover using your User ID and Password (they are case sensitive) at <http://honeywelldiscovertraining.com>

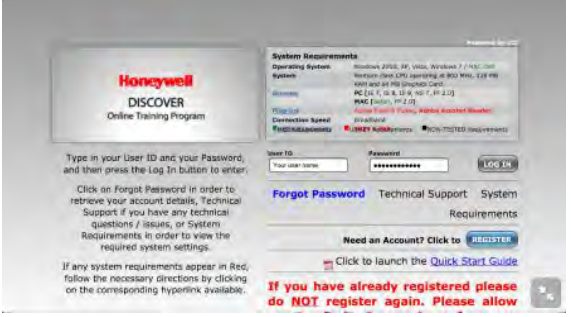
	<p>Navigate to Discover by entering the following address into internet explore.</p> <p><a href="http://www.honeywellsecurity.com/discover">www.honeywellsecurity.com/discover</a></p>
	<p>Look for the blue link called "Point, Click &amp; Learn".</p> <p>Clicking this will take you to the Discover login page.</p>
	<p>If you have a login then enter it, otherwise you can register from here. You <b>MUST</b> have an account for yourself or we will not track your learning and certification.</p>

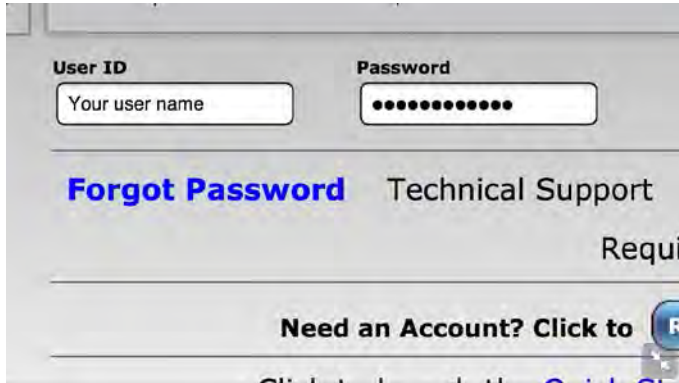

Enter your User ID and Password.

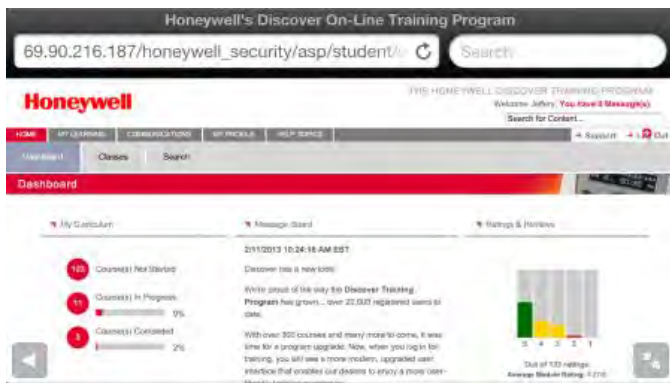

Discover will open at a page that displays your account.



Clicking on "My Learning" will open "My Courses".

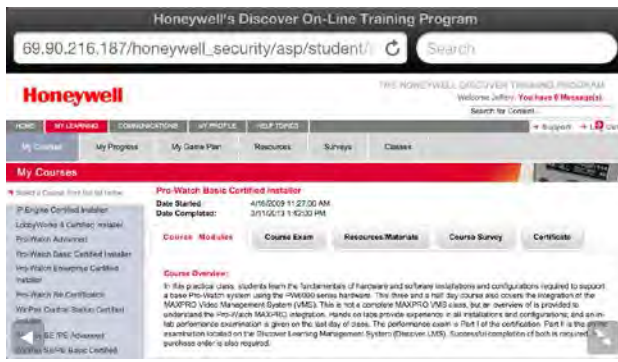

Scroll down the left hand gray menu to find the course you are taking.



**Pro-Watch Basic Certified Installer**  
 Date Started: 4/16/2009 11:27:00 AM  
 Date Completed: 3/11/2013 1:42:00 PM

Course Modules | **Course Exam** | Resources/Materials | Course Survey | Certificate

**Exam Overview:**  
 The Pro-Watch Basic Certified Installer exam consists of approximately 20 questions. You have 3 attempts to achieve a passing score of 80%. Upon completion of the exam your corresponding results will display on the screen and the course material will be available for review. If you do not achieve a minimum of 80% it is recommended that you review the course material once again before making any additional attempts.  
**Exam length:** 20 Minutes.

Click the Exam link to begin

Exam	Attempts	Score
Exam Complete	2	85%

Selecting the second tab, after you have completed the course will give you the link to the Online Exam.

Date Started: 4/16/2009 11:27:00 AM  
 Date Completed: 3/11/2013 1:42:00 PM

Course Modules | Course Exam | Resources/Materials | **Course Survey**

Please answer the following questions and then submit your response.

1 Overall Evaluation

- Excellent
- Good
- Average
- Fair
- Poor

Once you have completed the exam with a passing score, click the "Course Survey" tab and make your selection.

**Pro-Watch Basic Certified Installer**  
 Date Started: 4/16/2009 11:27:00 AM  
 Date Completed: 3/11/2013 1:42:00 PM

Course Modules | Course Exam | Resources/Materials | Course Survey | **Certificate**

Honeywell's  
 Discover On-Line Training Program

Jeffery Schwartz

You can then click the last tab, the "Certificate" tab, and print your certificate. You can come back and print it as many times as you need to.

Still having challenges with Discover? Check out the Quick Start Guide on Discover's home page, or contact customer service at (800) 223-9436 and someone will be available to assist with registrations and general questions.

# Pro-Watch Architecture

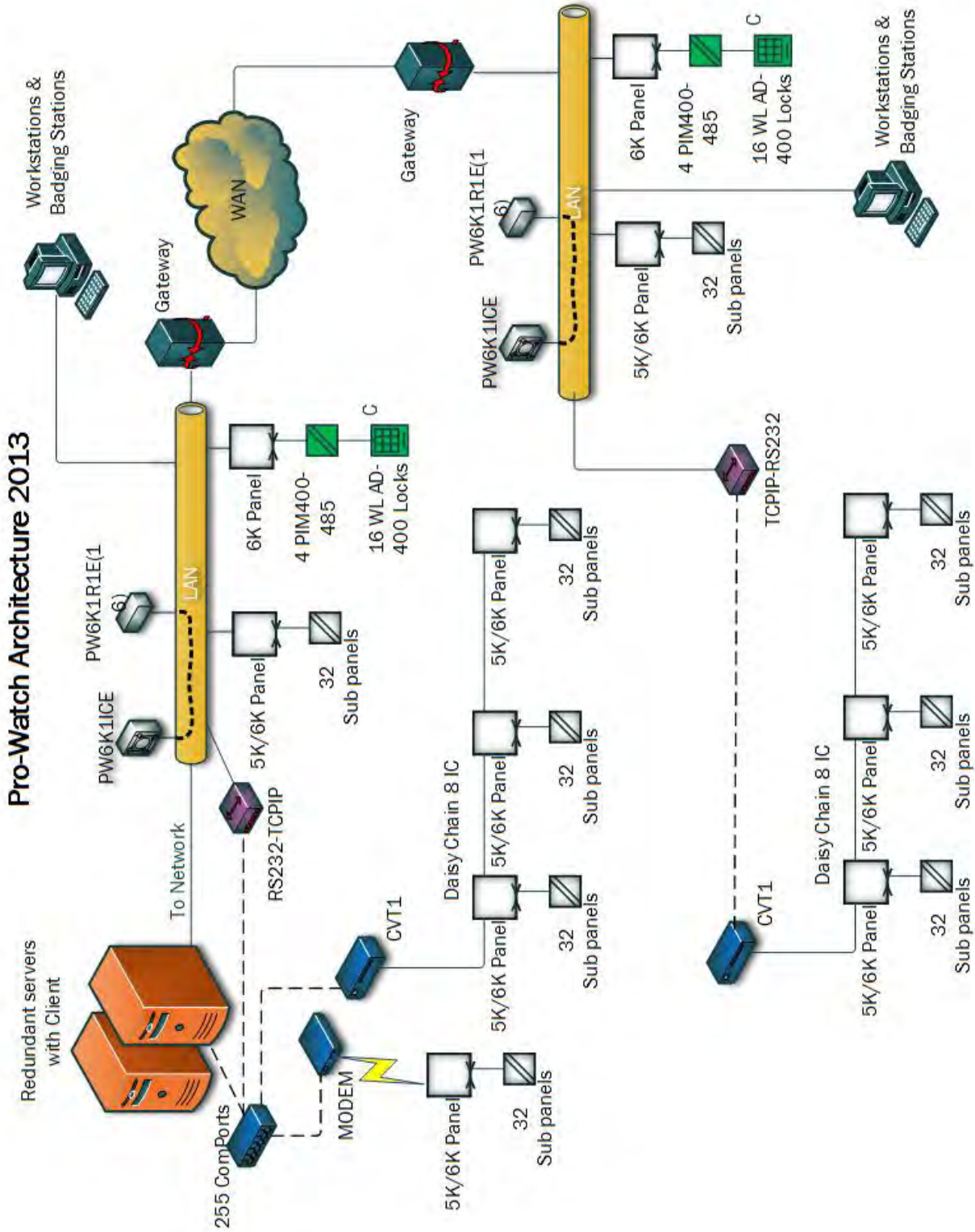



## Types of Pro-Watch

### The Different Versions of Pro-Watch

	PW Lite	PW Professional	PW Corporate
Readers	32	32 - 64	96 - 20,000
Clients	1 - 3	1 - 5	1 - unlimited
Badging Clients	0	1 - 5	1 - unlimited
Clearance Codes per Badgeholders	12	32	32
SQL2005 express	X	X	No Schedule 4GB
SQL2008 Express	X	X	No Schedule 4GB
SQL2005			X
SQL2008			X
<b>Win XE 563</b>			
Win Vista Business 32 bit	X	X	X
Win 7 Professional /Ultimate 32 or 64 bit	X	X	X
Win 2003 Server	X	X	X
Win 2008 Server 32 or 64 bit	X	X	X
Elevator Control			128 Floors



Not X Clients

Stand alone

# 1 Pro-Watch 4.0 Installation

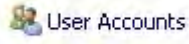

The installation of 4.0 is very close to the installation of 3.80 and 3.81. The biggest difference is the installation of the Web Client. Pro-Watch 4.0 only requires dotNet3.5 BUT the Web client requires dotNet4.0 (dot-NetFx40\_Full\_x86\_x64). If you feel you will be using the Web Client then install dotNet4.0 before you start the Pro-Watch install.

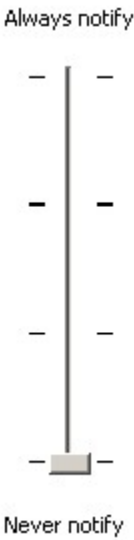

## User Account Control

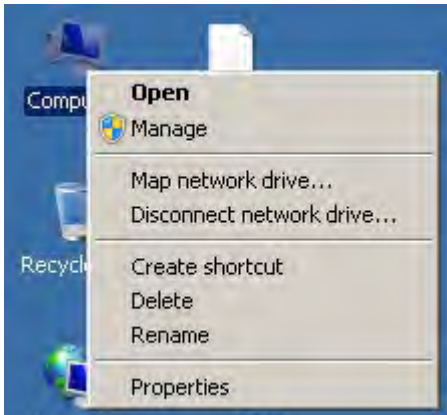
	<p>Open the Control Panel and click on User Accounts.</p>
	<p>Locate and click on "Change User Account Control Settings"</p>
	<p>Move the slider to "Never notify" at the bottom of the scale.</p> <p>REBOOT to make this take effect.</p>

## IE Enhanced Security

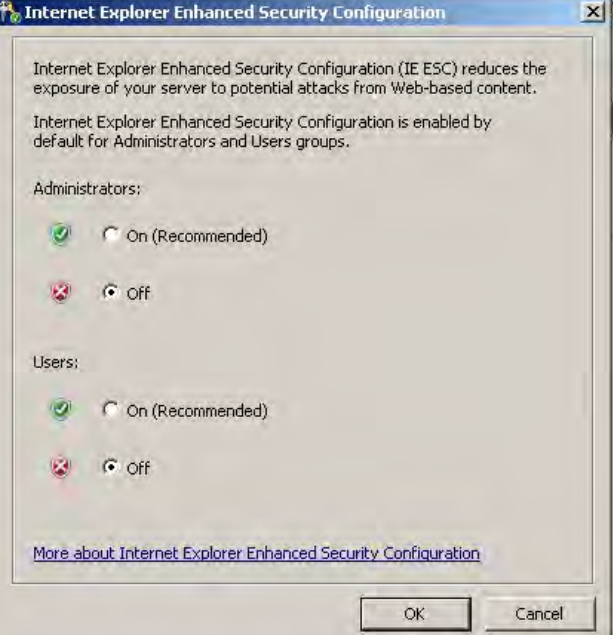
	<p>Next you have to turn off IE Enhanced Security or you will not be about to edit the PW6000 IC option when you log in to set the static IP address.</p> <p>Right click on Computer and select Manage.</p>
---	---

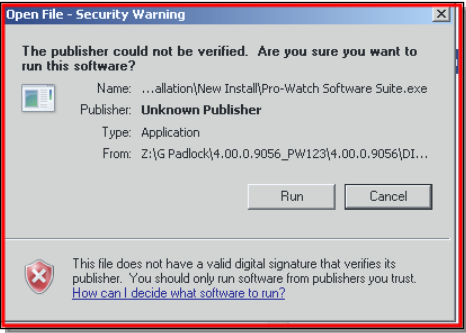
	<p>When the Server manager opens, highlight the top selection that says "Server Manager"</p>
	<p>On the right hand side you will find a menu. From the menu select "Configure IE ESC"</p>
	<p>Turn Enhanced security off for both Administrators and Users.</p> <p>Click OK</p>
<p>You should be able to install Pro-Watch.</p>	

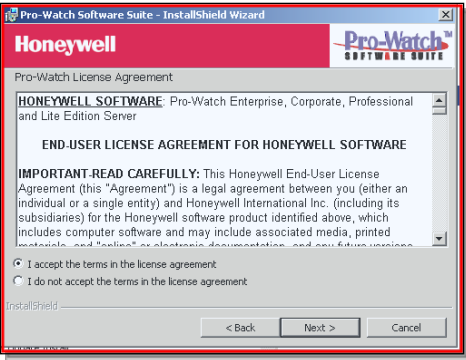
	<p>Step 1 – Navigate to the New Install folder and run the Pro-Watch Software Suite exe file. Make sure that the User Account Control Settings are turned completely down.</p>
	<p>Step 2 – Click Run</p>
	<p>Step 3 – Click Next</p>
	<p>Step 4 – Accept the license agreement and click the Next button</p>

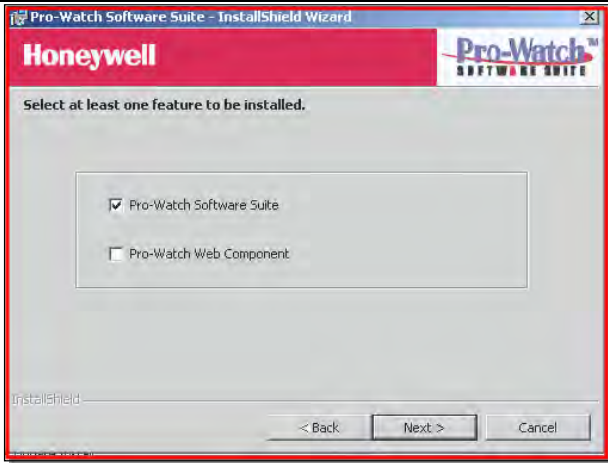

Step 5 – Select the features to be installed. If you go ahead and select the web client as well as the software suite, Pro-watch will install the necessary files and then you can decide later whether to use it or not.

Click Next

### Web Client

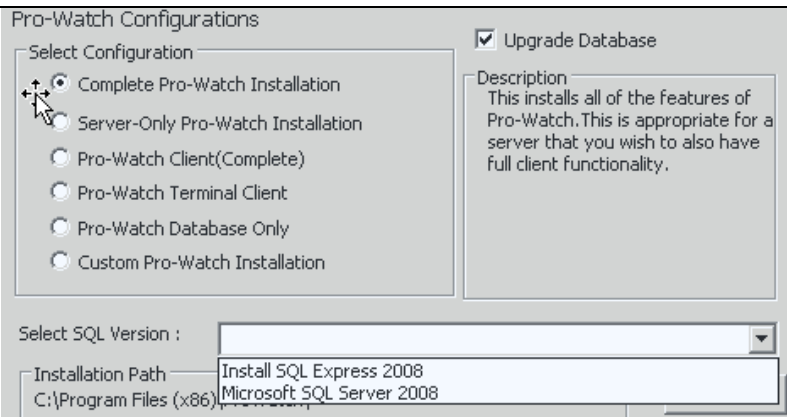

Step 6 – Select the Configuration you want, and select the type of SQL that is going to be used.

Click Next.

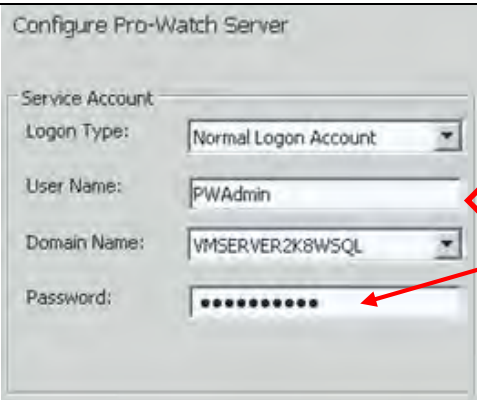

You're Login Name and Password

Step 7 – For now select the “Normal Logon Account” type, enter the administrator that is logged in presently, pick your Pro-Watch server name (the dropdown will list your server name), and enter the administrators password.

Click Next.

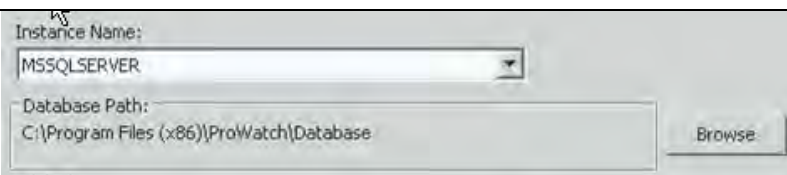

Leave the check mark in the box for “Use Local Database Server”. Choose the SQL Instance Name that you will be using. Use the Browse button to locate where the database will be stored.



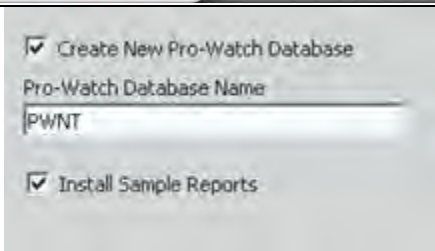

Step 9 - On the database name screen, leave the name at PWNT and click the Install Sample Reports check box.

**Sample Reports**

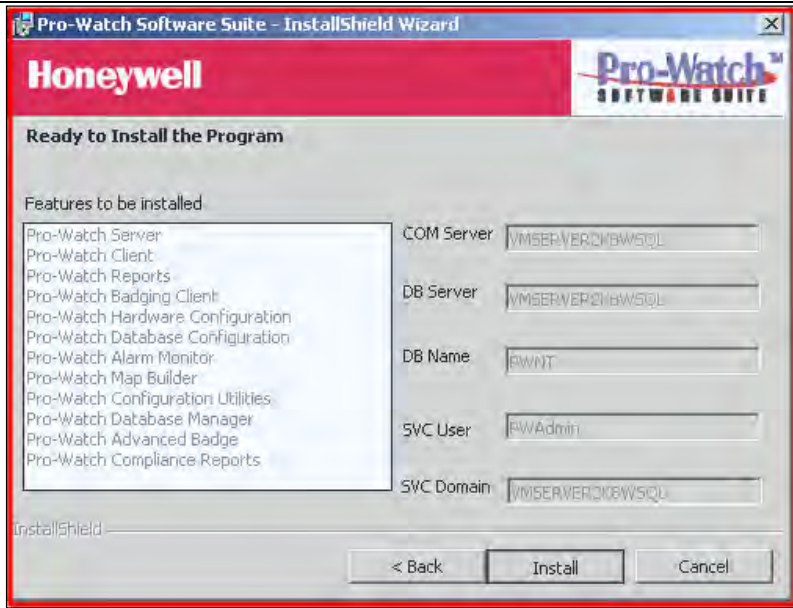

Step 10 – Click the Install button.

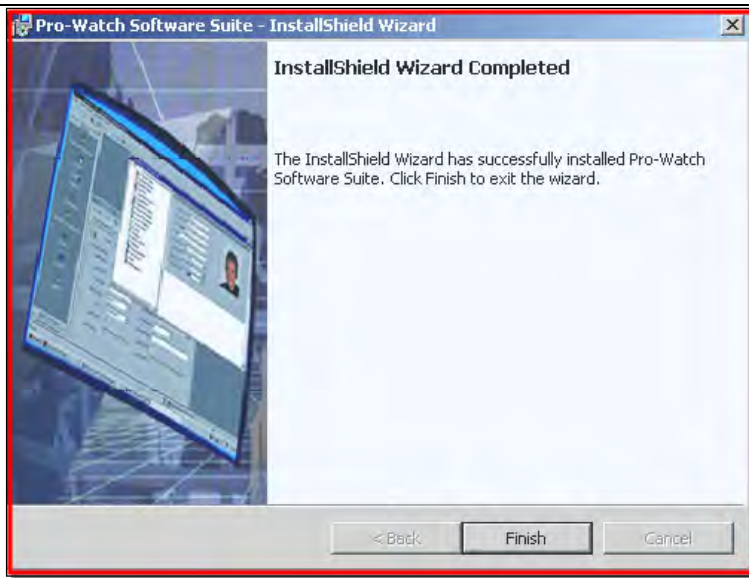

Step 11 – Let the install finish.

When the installation completes, be sure to reboot the server. After the server reboots you may find that you get a message that says that the client cannot connect to the server. This indicates that the Pro-Watch Server service is not started. There is also a problem with the service startup type and user. SEE Lab 1 – Part 2



**Backwards Compatibility Patch** - Install the SQL Backwards Compatibility Patch and reboot again. (Disk 1/ 64-bit updates to Server/ 64-bit Enterprise Manager Fix/ SQL 2005 Backwards Compatibility/Pick the package(IA64,x64,or x86) that matches your installation. NOTE: If you pick the wrong one it will tell you before it runs. Go back and pick the correct one.



**Lab 1**

**Lab 1 – Part 1 - Install Pro-Watch 4.0.**

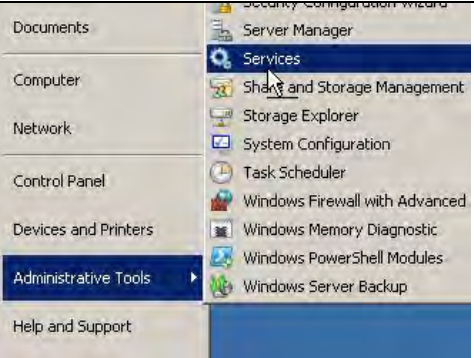
- a. Install with Sample Reports but not the Pro-Watch Web Component.
- b. Install the SQL Backwards Compatibility Patch and reboot again.

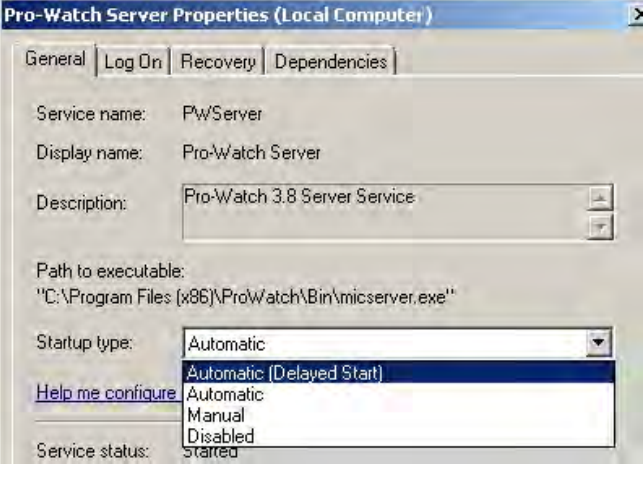
**Lab 1 – Part 2 – Fix Pro-Watch Server Service**

	<p>Navigate to the Pro-Watch Server service.</p>
	<p>Double click the service</p>
	<p>On the general Tab, set the Startup Type to “Automatic (Delayed Start)”.</p> <p>The reason is to let the SQL services get started before the Pro-Watch service tries to start.</p>

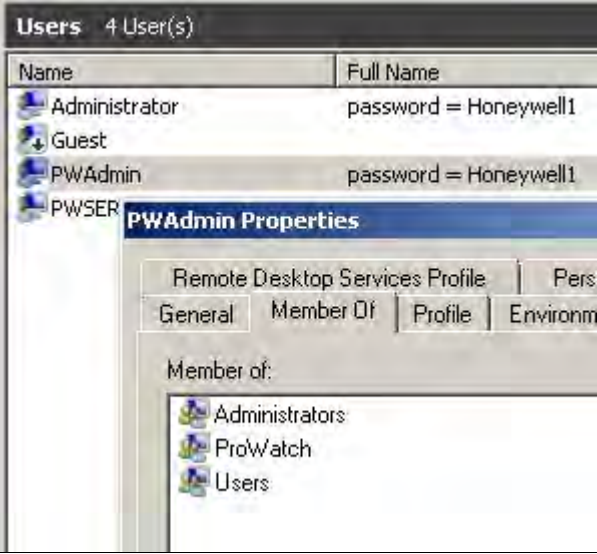
	<p>Next on the Log On tab you will find the name of the user that you were logged in with when you installed Pro-Watch. IT will probably disable you as an administrator. Enter the user name and password that IT wants you to use.</p>
	<p>Be sure that the user is a member of the Pro-Watch user group.</p>
	<p>Check the general tab of the Windows Pro-Watch User Group. If the startup user for the service is not in this user group, then the service won't start.</p>
	<p>You can also check by looking at the "Member Of" tab of the user.</p>

**Lab 1 - Part 3 - Do an Immediate Backup.** Put the backup file on the Desktop.

Select the Pro-Watch Enterprise Manager menu item

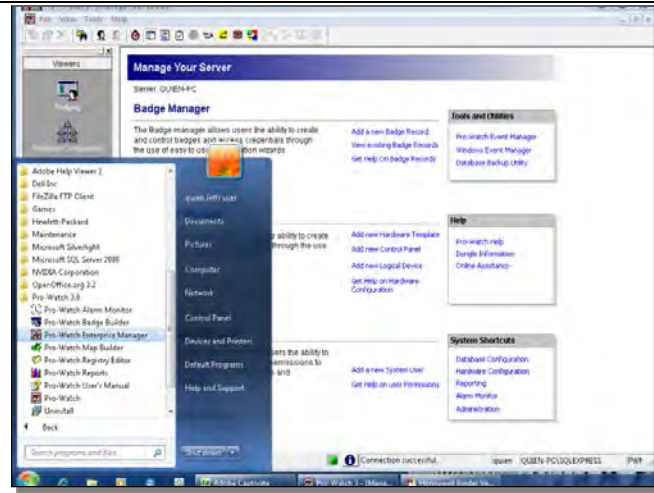

Expand the menu and select the Backup Database item. By default the Complete Backup radio button will be selected. Enter a description for your backup. Decide if the backup will be a complete or a differential. Click the Next button.

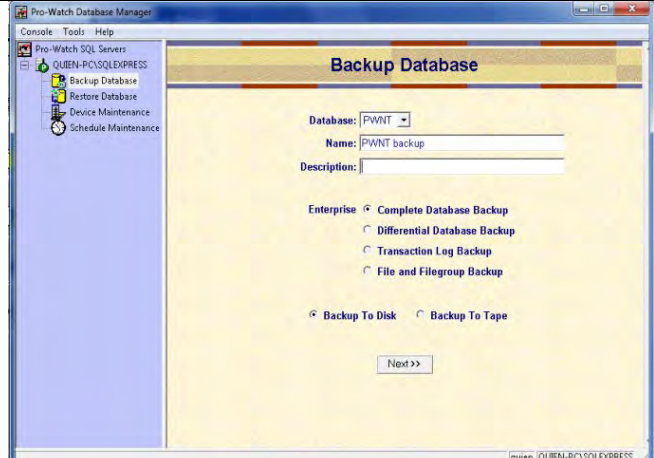

Use the ellipses browse button to locate the place you want to store the backup and then give the backup a name. Use the file extension of .bak. You also want to decide if this backup is going to be appended, or added to the previous backup, or whether it will replace the previous backup.

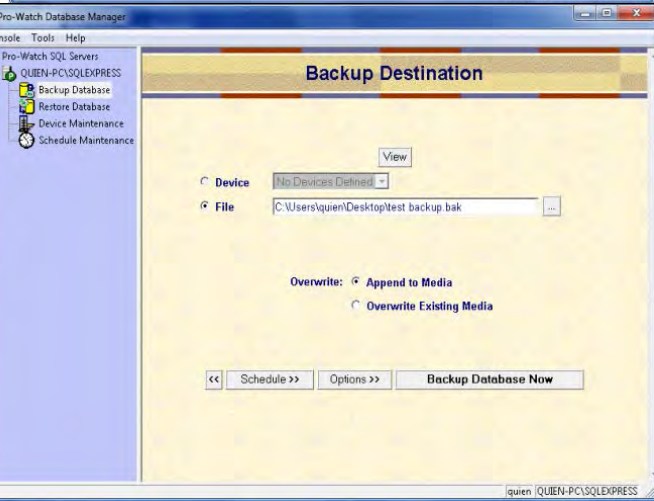



If you click the Backup Database Now button, it will immediately start backing up the database. The other option would be to schedule the backup to run repeatedly at a certain day or date, and time.







## 2 - HID and License

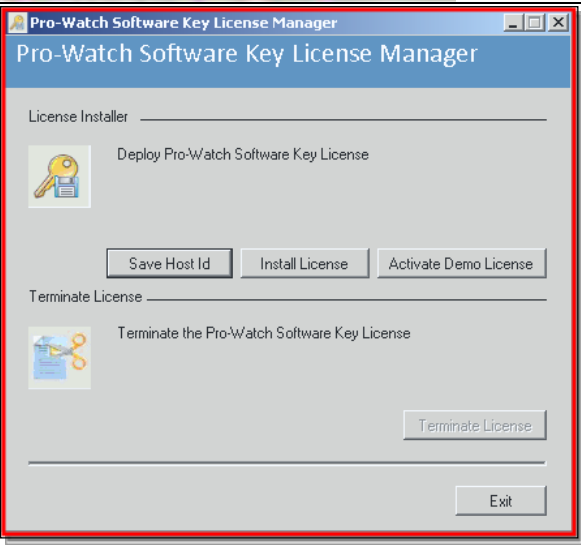

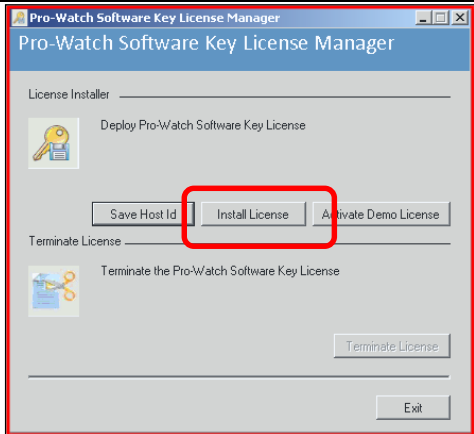
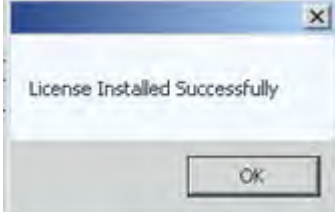
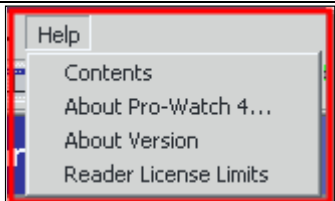
The Licensing process is very simple. Create an HID file, email it to Honeywell, Honeywell will email back a .cert file. Run the license utility to install the .cert file, and then reboot.



	<p>Step 1 – From the Start button select “All Programs”, Pro-Watch 4.00 / and then choose “Pro-Watch Software Keys Manager”.</p>
	<p>Step 2 – Click the “Save Host ID” button.</p> <p>HID File</p>
	<p>Step 3 – Save the file somewhere and email it to Honeywell. Honeywell will then create a file with the extension of “.cert” and email it back to you.</p>

	<p>Step 4 – Copy the .cert file to a location on the server and click the “Install License” button.</p> <p><b>Install License</b></p>
	<p>The license will install and an information dialog will indicate the success.</p>
	<p>Step 5 – Reboot the server.</p>
	<p>Step 6 – Open Pro-Watch and open the Help file.</p> <p>Click the About Version menu selection.</p>
	<p>Step 7 - Check to see that the Voucher No. does not say “Evaluation”. If it does then the license did not install correctly.</p> <p><b>Voucher</b></p>

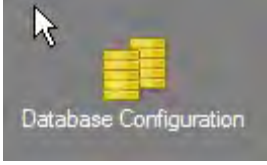
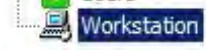

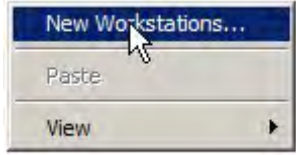
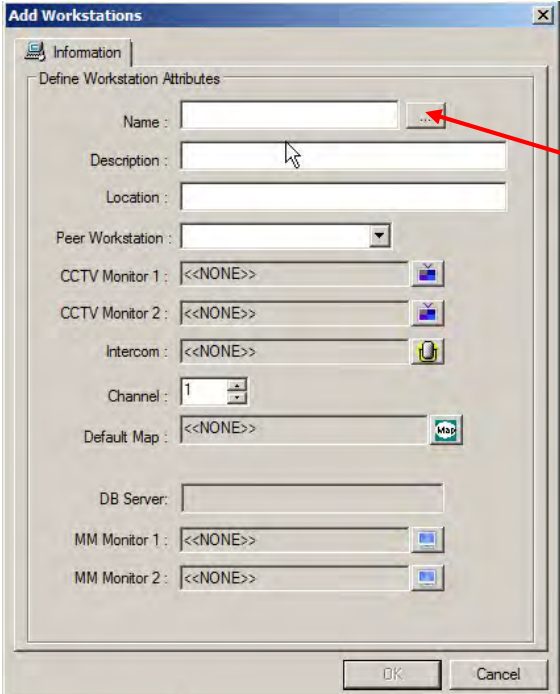
**Lab 2 – Generate an HID File on the Desktop and License the software.**

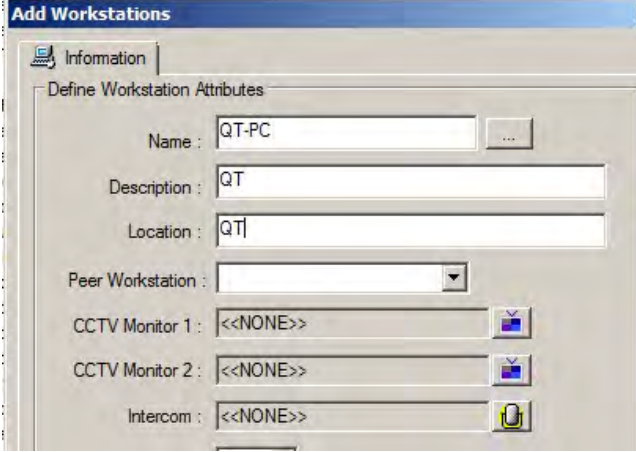
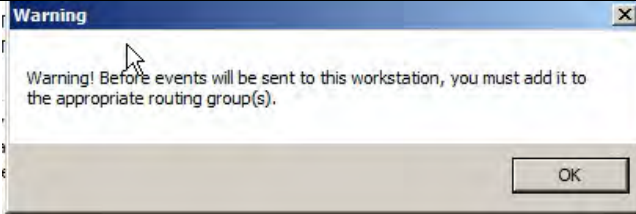
### 3 - Workstations

 <p>Database Configuration</p>	<p>Select Database Configuration</p>
 <p>Workstation</p>	<p>Select Workstations</p>
 <p>pwserver VMSERVER.2K3 WSQL</p>	<p>In the default installation, you will find a bogus workstation called "pwserver", and the workstation you were at when you installed the software.</p>
 	<p>Right click in the right hand window and select New Workstation.</p> <p>An empty workstation dialog box will open.</p> <p>Use the browse button to browse the network and find the workstation names that you want to be able to log into Pro-Watch at.</p>

	<p>Highlight the workstation and click OK.</p>
	<p>The top box will be filled in with the selected workstations name. You must fill in the boxes for "Description", and "Location".</p> <p>Nothing else is needed, click the OK button.</p>
	<p>A warning will popup. Ignore it for now.</p>
	<p>You will see your new workstation.</p>

## 17 - Classes

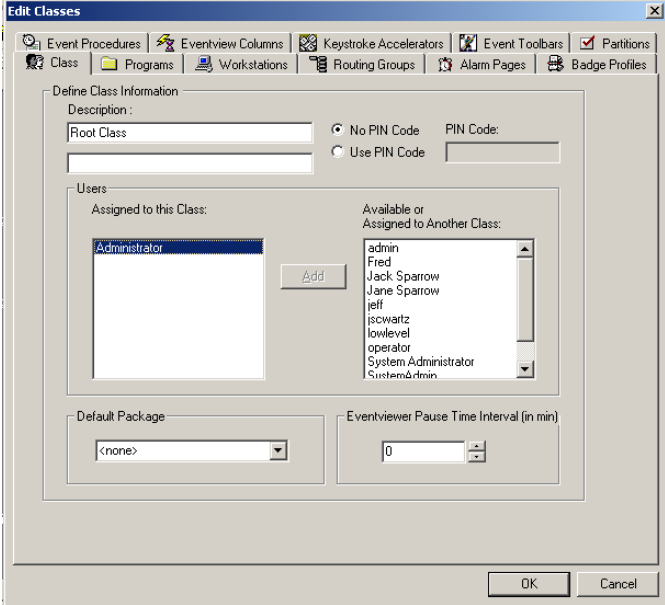
	<p>Classes could also be called user groups. A class will contain the privileges that a user receives if the user is assigned to a class. It also defines other aspects of the user. This module will explain the basics of a class. To view or edit a class click the <b>Database Configuration</b> icon in the viewer bar on the left.</p>
	<p>Select the Classes item</p>
	<p>To open a class to view it or edit it, you can double click it, or right click it and select properties from the menu. The Root class is the default administrator class. Open the Root Class.</p>
	<p>The first tab is the Class tab. It defines the name of the class and indicates which users are assigned to the class. The window next to the "Assigned to this Class" window is a list of users that are available to be assigned to the class. Be careful when using these windows. Pro-Watch does not warn you if the user you are moving from "Available" to "Assigned" is already assigned to a different class. It will allow you to move any user in and out of any class. This is a problem since you could move a user with few rights into a class with admin rights, and you can also move your administrators out of the Root class into a class without any rights.</p>
	<p>The <b>Event viewer Pause Time Interval (in min)</b> text box lets you set the number of minutes that you can</p>



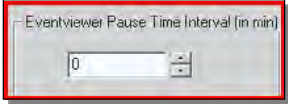

Eventviewer Pause Time Interval (in min)

0

pause the Event viewer. By default the event viewer continuously scrolls events down the screen as they occur. You can pause the screen. This setting determines how long it will stay paused.

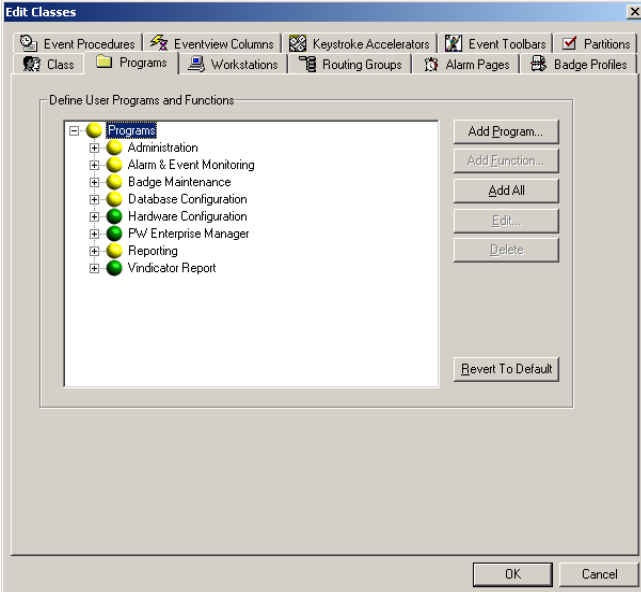

Edit Classes

Event Procedures | Eventview Columns | Keystroke Accelerators | Event Toolbars | Partitions

Class | Programs | Workstations | Routing Groups | Alarm Pages | Badge Profiles

Define User Programs and Functions

- Programs
- Administration
- Alarm & Event Monitoring
- Badge Maintenance
- Database Configuration
- Hardware Configuration
- PW Enterprise Manager
- Reporting
- Vindicator Report

Add Program...  
Add Function...  
Add All  
Edit...  
Delete

Revert To Default

OK Cancel

The programs tab defines what a user can do in Pro-Watch. Each of the topics was many options so that you can precisely define what a user can do. There are three colors associated with the tree. Red means no rights, yellow means partial rights, and Green means that everything is enabled. You don't necessarily want everything to be green. Some of the things that are turned off by default are things that limit, or cause the user to fill out data in a note when they do things.

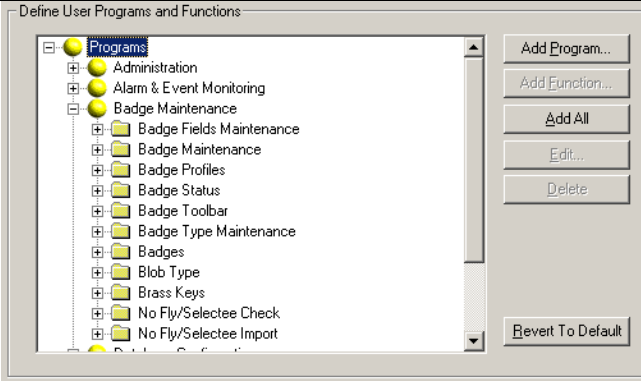

Define User Programs and Functions

- Programs
- Administration
- Alarm & Event Monitoring
- Badge Maintenance
  - Badge Fields Maintenance
  - Badge Maintenance
  - Badge Profiles
  - Badge Status
  - Badge Toolbar
  - Badge Type Maintenance
  - Badges
  - Blob Type
  - Brass Keys
  - No Fly/Selectee Check
  - No Fly/Selectee Import

Add Program...  
Add Function...  
Add All  
Edit...  
Delete

Revert To Default

If you expand a section it opens a list of the things that you can control.

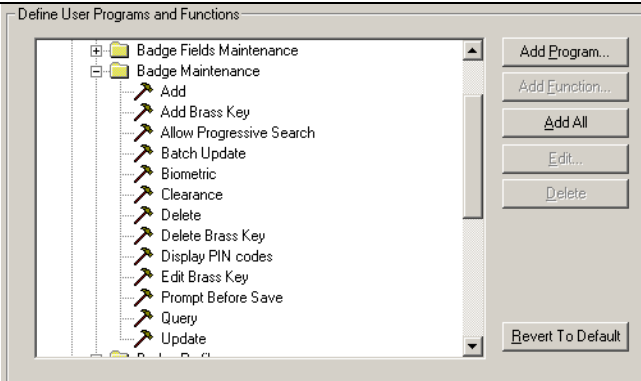

Define User Programs and Functions

- Badge Fields Maintenance
- Badge Maintenance
  - Add
  - Add Brass Key
  - Allow Progressive Search
  - Batch Update
  - Biometric
  - Clearance
  - Delete
  - Delete Brass Key
  - Display PIN codes
  - Edit Brass Key
  - Prompt Before Save
  - Query
  - Update

Add Program...  
Add Function...  
Add All  
Edit...  
Delete

Revert To Default

If you expand one of those you get a list of the things you can do with that selection. The things with a folder are Programs, and the things with a hammer are functions. To set the controls on a program you add or delete functions. Browse through the settings for the Programs to become familiar with them.

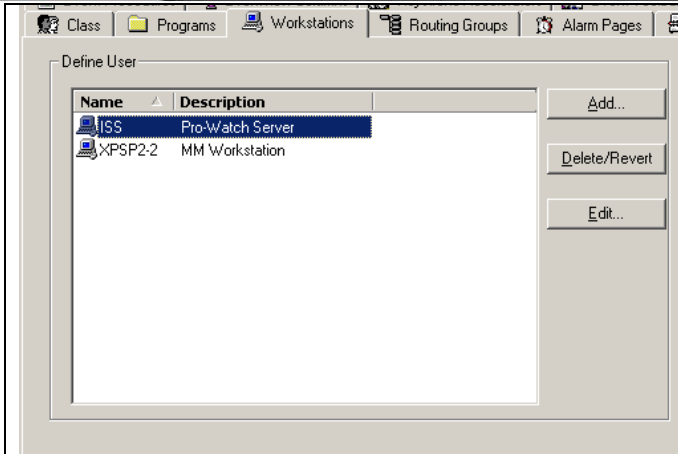

The Workstations tab displays a list of the clients that anyone with this class assigned to them can open Pro-Watch from. If the workstation is not in this list you will get an error that says "Invalid Workstation for Login".

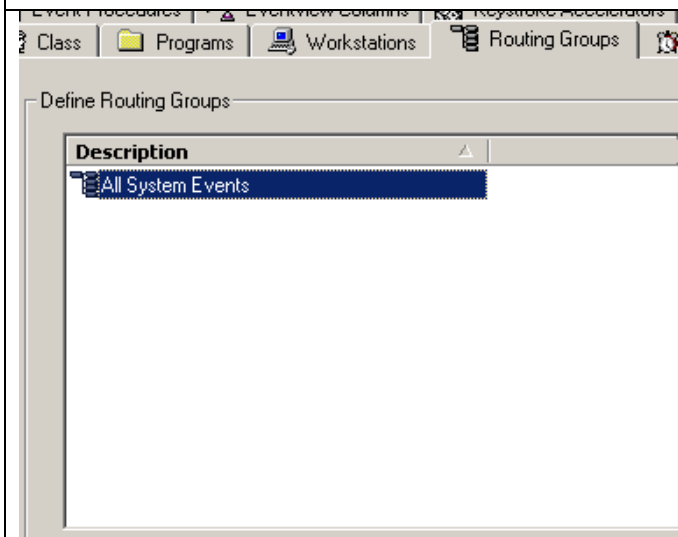

The Routing Groups tab defines what events you will be able to receive at your workstation. Routing Groups will be discussed in another module. This is where you assign the Routing groups that you make to the users you have.

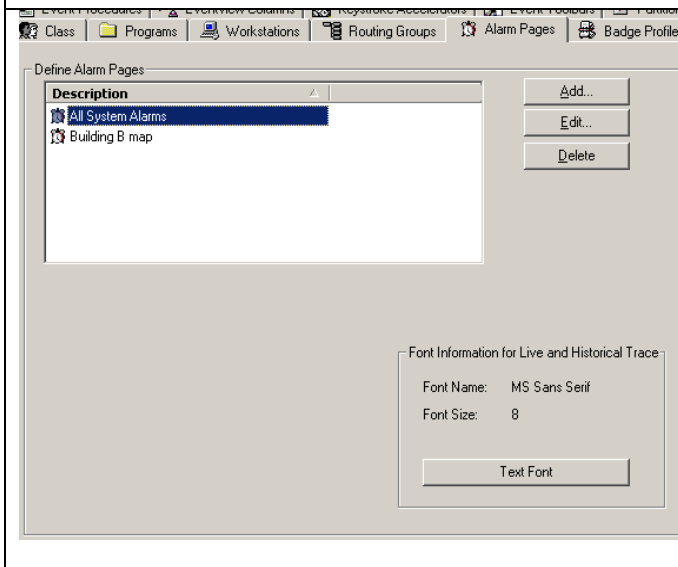

The Alarm Pages tab defines what type of alarm page you will get when you open the Alarm Monitor. By default everyone gets the All System Alarms page. This is a Text view with columns. Maps are also available. An Alarm page defines the events that come to your screen, as well as the style. It can be Text or Maps, or both.

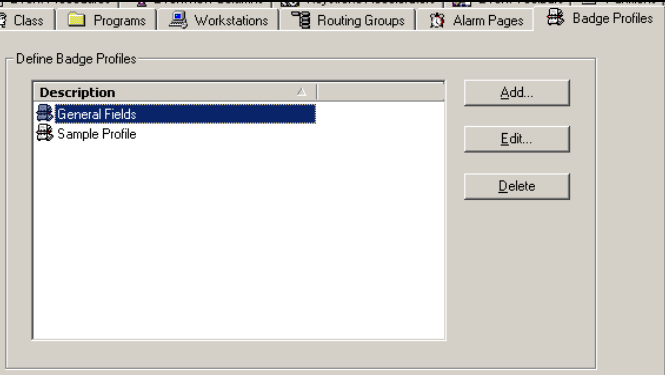
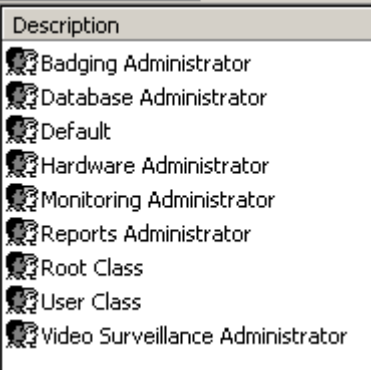
	<p>Finally, the Badge Profiles tab determines which Badge Profile you will have assigned to you as a user. A Badge Profile is a graphic layout of the data you can view when you look at the card holder data.</p>
	<p>There are several basic classes already setup in Pro-Watch. They lay out the abilities that are generally needed to perform the function they are named for. The only exception is the Default Class. This one should be left alone. Users that are not assigned to a particular class get the default class assigned to them. This will be discussed more in the module on Users not in a Class.</p>
<p>You are not limited to just these classes. You can make your own from scratch, or these can be copied and then edited to fill your specific needs.</p> <p>To make your own Class, Right click the window and select New Class from the menu. You will then need to fill out all of the data in the bottom row of tabs.</p>	

## 18 - Users

A User in Pro-Watch is a person who needs to open the software suite for any reason. Some users have administrator rights and some may only have the right to open the alarm monitor and watch alarms occur. The rights and options that apply to a user come from the Class that they belong to. The class passes down all of the settings for the user. You do have the ability to re-edit all of these settings at the user level. Any changes at the user level only affect the one user being edited.

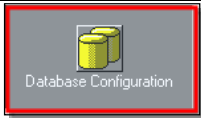

To add or edit a user, click Database Configuration in the viewer bar on the left.

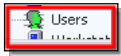

Select the Users item

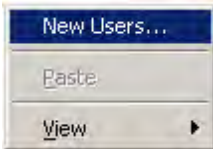

Right click the window on the right and select New User from the menu.

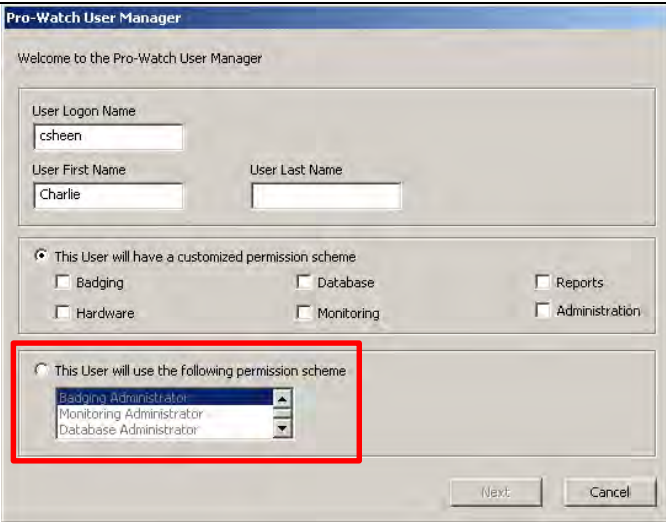

Select the "This User will use the following permission scheme" radio button. This will enable the list of Classes. Select the appropriate Class for this user. When the "Pro-Watch User Manager" dialog opens, enter the user's Windows' logon name in the "User Logon Name" box.

Click the Next button.



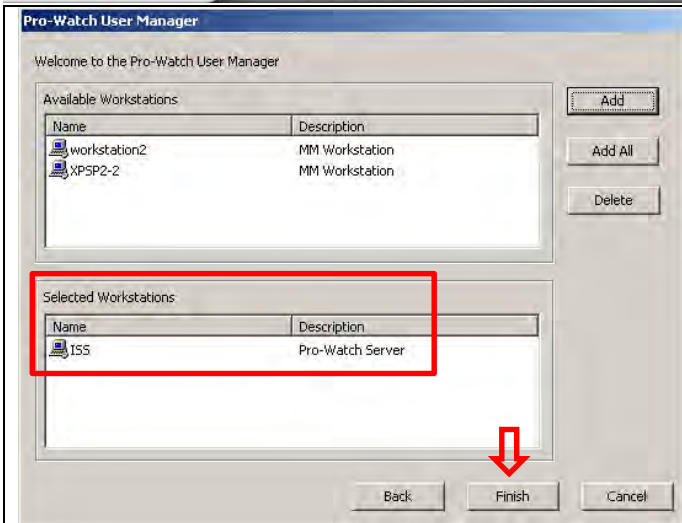

When the Workstation screen opens, select the client or clients that this user will be allowed to open Pro-Watch on.

Select the workstation and click the Add button. This will move the Workstation from the upper window to the lower window. The workstations in the lower window are the workstations that this user can use. Trying to open Pro-Watch on any other workstation will cause an error. The error is "Invalid Workstation for Logon."

Once the workstation has been added, click the Finish button

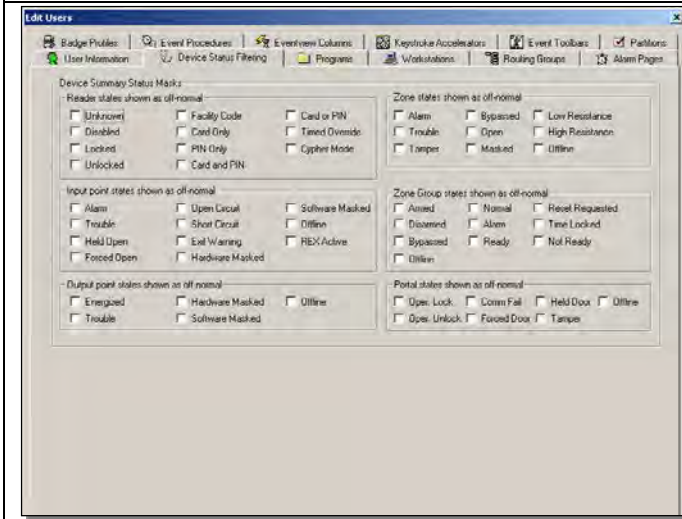

The only thing left is to reopen the user and place check marks in the events on the Device Status Filtering tab. These will be the events that will show changing icons for this user. If these are not checked then the logical device icons will not change to indicate the condition of the device.

This tab does not exist in Classes.



## 19 - Users from Roles instead of a class.

A User in Pro-Watch is a person who needs to open the software suite for any reason. Some users have administrator rights and some may only have the right to open the alarm monitor and watch alarms occur. The rights and options that apply to a user come from the Class that they belong to. The class passes down all of the settings for the user. You do have the ability to re-edit all of these settings at the user level. Any changes at the user level only affect the one user being edited.

Open the New User wizard the same way you did in the previous section. Fill out the Logon Name, User First Name, and the User Last Name. This time you will choose one or more of the roles in the section named "This User will have a customized permission scheme". These permissions are the "Roles" for this user.

Click Next and move the appropriate workstations from the "Available" workstations window to the lower "Selected" workstations window. After selecting the workstations, click the Finish button.

Reopen the User Properties. Notice the **Class Id** text box. The Default class is used for all users that use the Permissions roles. Do not edit the Default Class as it will affect all permissions users. If a Permissions user needs to be edited, do it at the user level, not the class level.

It is still necessary to check the boxes on the "Device Status Filtering" tab.

### Lab - Users from Class

1. Click Database Configuration.
2. Select the Users item
3. Select the **New Users...** menu item
4. Enter the Windows Logon Name of "jbourne".
5. Enter Jason for the User First Name.
6. Enter "Bourne" for the User Last Name.
7. Select the This User will use the following permission scheme radio button
8. Click the scroll bar
9. Select the Monitoring Administrator item
10. Click the **Next** button
11. Select the Workstation name that this user will be using.
12. Click the **Add** button
13. Click the **Finish** button
14. End of Lab

### Lab - User Roles from Permissions

1. Select the Database Configuration item.
2. Select the User item
3. Right click the right hand window.
4. Select the **New Users...** menu item
5. Enter "jdoe" for the User Logon Name.
6. Enter John for the User First Name.
7. Enter Doe for the User Last Name.
8. Under the heading of "This User will have a customized permission

scheme, Select the **Badging** check box

9. Select the **Database** check box

These Permissions are the "Roles" for this user.

10. Click the **Next** button

11. Select the workstation that this user will logon from.

12. Click the **Add** button

13. Click the **Finish** button

14. Double-click the **John Doe** item

15. Notice the **Class Id** text box. The Default class is used for all users that use the Permissions roles. Do not edit the Default Class as it will affect all Permissions users. If a Permissions user needs to be edited do it at the user level, not the class level.





16. Select the **Programs** tab and notice that the permissions you checked have now turned on certain programs.

17. Click the OK button.

18. End of Lab.

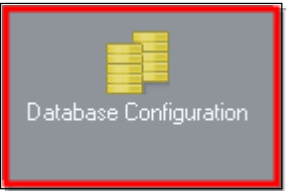
### 4- Time Zones

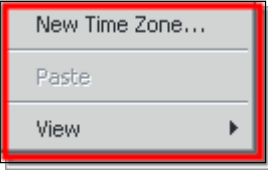
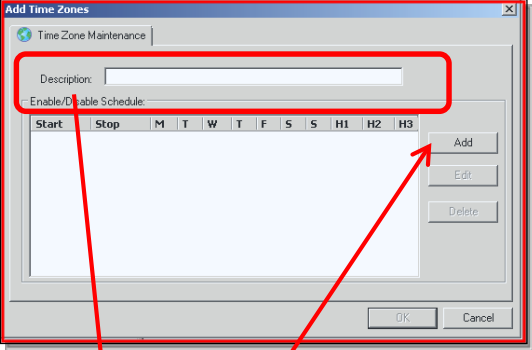
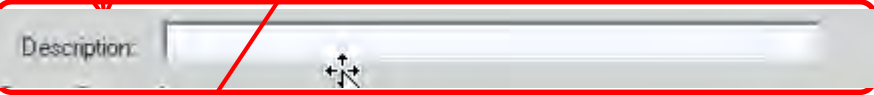
Time zones are used to automatically control devices and allow access to valid cards. These should be built before you build the panels since they have to be uploaded to the panels.

	<p>Step 1 - To create a Time Zone, click Database Configuration, and then Time Zones.</p>
	<p>Step 2 – Select the Time Zones database item.</p>
	<p>Step 3 – Right click in the right hand window and select “New Time Zone...”.</p>
 	<p>Step 4 – Fill in the Description. It should include the actual Start and End Times if possible.</p>
	<p>Step 5 – To add start and end times to the Time Zone, click the “Add: button.</p>
<p>A time zone will have at least one start and end time, but it can have up to 12 start and end times. It is designed this way because you can only assign one time zone to a device or a clearance code. If conditions for the operation of a device require different times for normal or holidays then all of those conditions need to be in a single time zone.</p>	

**Enable/Disable Time**

Define Enable and Disable Times

Start Time : 8:00:00 AM

Stop Time : 5:00:00 PM

In Use :

Define Enable and Disable Days

Monday       Tuesday

Wednesday       Thursday

Friday       Saturday

Sunday       Holiday 1

Holiday 2       Holiday 3

OK      Cancel

Step 6 – Set the start and end times and then put a check in the box next to the days of the week and holidays when the times are supposed to be valid.



Enable/Disable Schedule:

Start	Stop	M	T	W	T	F	S	S	H1	H2	H3
8:00:00 AM	5:00:00 PM										
9:00:00 AM	11:00:00 ...										

Step 7 – The blue days are the days when the times will be active. If additional time entries are needed then click the Add button and repeat the process. Click OK. The schedule will look like the one to the left. You can have up to 12 lines of time in each Time Zone.

## 5 - Holidays

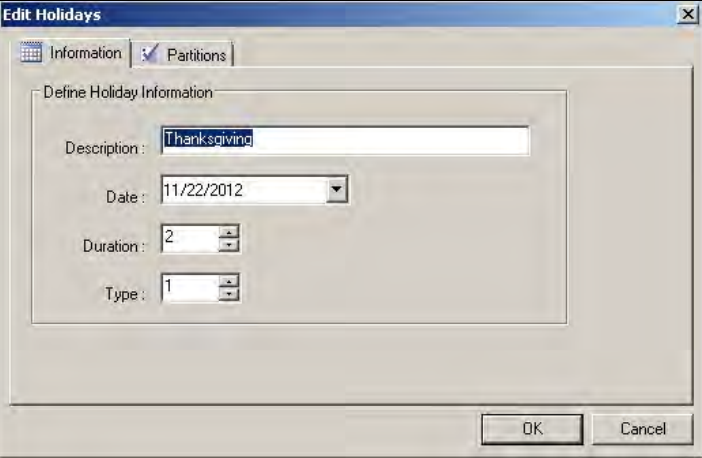
Holidays are actually just dates during the year that have been designated as an H1, H2, or H3 day. No matter what day of the week the holiday falls on the device will follow the time zone that has a blue mark in the H1, H2, or H3 line of time. It will ignore the normal times. A holiday starts at midnight and lasts a minimum of 24Hrs up to 365 days.

	<p>Step 1 - To setup a Holiday, select Holidays from the list under Database Configuration.</p> <p>Then right click "Holidays" and select "New Holiday..." from the menu.</p>
	<p>Step 2 – Give the holiday a description.</p> <p>Then use the drop down for Date: and select the start date of the Holiday.</p> <p>Holidays can be longer than one day. Use the "Duration:" box to determine how many 24hr periods long the holiday will be. The last thing is to set the Type:. Type is 1 for H1, 2 for H2, and 3 for H3. When finished click the OK button.</p>
 <p>Thanksgiving</p>	<p>Step 3 – There are two icons for holidays.</p> <p>If the holiday has not occurred.</p>
 <p>New Years Eve and Day</p>	<p>If the Holiday is past.</p>

All holidays can be opened and then edited for the next time the holiday occurs.

### Lab 3 – Create Time Zones and Holidays

To make a time zone select Database Configuration from the viewer bar at the right. Then scroll down until you locate the menu selection for Time Zones.



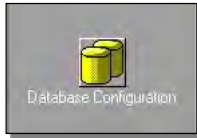

1. When you have highlighted the Time Zones menu selection, right click the right hand window.

2. Select the **New Time Zone...** menu item

A rectangular button with a light grey background and a thin black border. The text "New Time Zone..." is centered on the button in a black, sans-serif font.

3. When the Add Time Zones dialog opens it is necessary to enter the time zone description. In this case the description is 8am to 5pm Monday thru Friday. .

4. Click the **Add** button

A rectangular button with a light grey background and a thin black border. The text "Add" is centered on the button in a black, sans-serif font.

5. Enter the start and end times. In this case the start time is 8am and the end

time is 5pm.

A small dialog box with a light grey background and a thin black border. It contains two rows of time selection controls. The first row is labeled "Start Time:" and has a value of "8:00:00 AM" with a small dropdown arrow to its right. The second row is labeled "Stop Time:" and has a value of "5:00:00 PM" with a small dropdown arrow to its right.

6. Next select the days of the week that you want the time zone to be effective on.

7. Select the **Monday** check box

A rectangular button with a light grey background and a thin black border. It contains a small square checkbox followed by the text "Monday" in a black, sans-serif font.

8. Select the **Tuesday** check box

A rectangular button with a light grey background and a thin black border. It contains a small square checkbox followed by the text "Tuesday" in a black, sans-serif font.

9. Select the **Wednesday** check box

A rectangular button with a light grey background and a thin black border. It contains a small square checkbox followed by the text "Wednesday" in a black, sans-serif font.

10. Select the **Thursday** check box

A rectangular button with a light grey background and a thin black border. It contains a small square checkbox followed by the text "Thursday" in a black, sans-serif font.

11. Select the **Friday** check box

A rectangular button with a light grey background and a thin black border. It contains a small square checkbox followed by the text "Friday" in a black, sans-serif font.

12. After the start times, end times, and days of the week have been selected,

click the OK button to close the dialog.

A rectangular button with a light grey background and a thin black border. The text "OK" is centered on the button in a black, sans-serif font.

13. After creating the time zone, click the OK button to save and exit the Add

Time Zone dialog box.

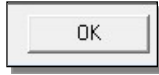

14. Add a second Time Zone. Right click the right hand window.

15. Select the **New Time Zone...** menu item

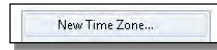

16. When the Add Time Zones dialog box opens, enter the Description. 8am-5pm M-F and Holidays

17. Click the **Add** button



18. After entering the times select the days of the week and which holidays to have this time zone effective.

19. Select the Monday check box



20. Select the **Tuesday** check box

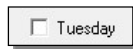

21. Select the **Wednesday** check box

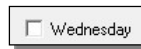

22. Select the **Thursday** check box



23. Select the **Friday** check box



24. Select the **Holiday 1** check box

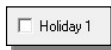

25. Click the **OK** button

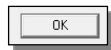

26. When the time zone is completed, click the OK button to save and close the window.

27. Add another Time Zone.

28. Right Click the Right Hand window

29. Select the **New Time Zone...** menu item

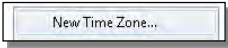

30. Make a Time Zone named Gate Operator

31. Click the **Add** button

32. Set the start time at 7am and the end time at 8am

Select the **Monday** check box



33. Select the **Tuesday** check box

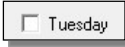

34. Select the **Wednesday** check box



35. Select the **Thursday** check box



36. Select the **Friday** check box



37. Click the **OK** button



38. Click the **Add** button



39. Set the start time to 4pm and the stop time to 5pm.

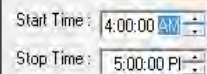

Start Time : 4:00:00 AM  
Stop Time : 5:00:00 PM

40. Select the **Monday** check box



41. Select the **Tuesday** check box



42. Select the **Wednesday** check box  Wednesday

43. Select the **Thursday** check box  Thursday

44. Select the **Friday** check box  Friday

45. Click the **OK** button

46. Click the **Add** button

47. set the start time to 8am and the end time to 9am.

48. Select the **Saturday** check box  Saturday

49. Click the **OK** button

50. Your window should look like this.

Start	Stop	M	T	W	T	F	S	S	H1	H2	H3
7:00:00 AM	8:00:00 AM										
4:00:00 PM	5:00:00 PM										
8:00:00 AM	9:00:00 AM										





51.

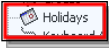
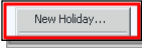
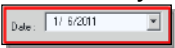

52. Click the OK button to close the window

53. End of Time Zone LAB

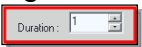
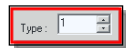
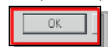
1. **Holidays** and Time zones work together. In Time Zones you saw the H1, H2, and H3 boxes. These refer to the three different types of Holidays that are supported in the PW series panels. The rest of the panels can only support

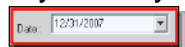
the H1 type of holiday. Having three different types of holidays gives you more flexibility.

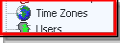
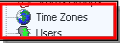
2.  From the viewer bar on the left select the Database Configuration menu item.
3.  Select the item  
After finding Holidays, right click the right hand window.
4. Right Click
5.  Click the New Holiday... menu item
6. Select the Description text box  
When the Add Holidays dialog opens give the Holiday a name. In this case it will be July 4th.
7.  The next step is to pick the starting date. Selecting the drop down box for the date will open a calendar.
8.  Using the calendar, locate the starting date for the holiday. It is the starting date because holidays can last for more than one 24 hour period.
9.  Using the duration box, select how long the holiday will last. The number represents days up to 365 days.
10.  The Type text box allows the user to select whether the date is an H1, H2, or an H3 type date.
11.  When you have added the description, the date, the duration, and the type, click the OK button to save and exit the Add Holidays dialog.
12. The new holiday has been added to the list and you can see that it is a calendar, while the other holiday is red. The calendar holidays are dates that have not occurred yet and the red ones are the past holiday dates.
13. The dates now have to be down loaded to the appropriate control panels. This has to happen every year because none of the dates in Pro-Watch can be setup as re-occurring dates. You do not have to create new holidays every year though. All that has to be done is to update the date on the existing holidays.
14.  Double-click the red holiday. In this case it's the New Year's Eve and Day Holiday.
15.  Select the Date dropdown list  
Every year some of the holiday dates change. There are two ways to update the expired holidays. Once they are opened you can click the date drop down and use the calendar, or select the part of the date that you want to update. In this case the month and days are the same, but the year is wrong so we just click the year part of the date. Now either type in the new year or use the up and down arrow keys to change the date.
16. We used the up arrow to change the year to the current year.

17.  The holidays can now be uploaded to the control panels.
18.  As a reminder of how to select the way holidays affect the system, open the time zone database.
19. Right Click
20.  Remember that there are three types of holidays. For each line of time you can determine how the time zone will function on the holiday. If you do NOT want anything to happen on the holiday then don't select any holiday types. If you DO want the line of time to be in effect ON the holiday then select the appropriate holiday type. 



As the system is being built it is necessary to organize the hardware in a manner that is logical. Pro-Watch uses the term “Site” as the top “folder” in the tree of hardware devices. The process is to build a site, then a channel and then a panel.

The Site references the Pro-Watch server. All of the sites will always reference the same server since it is the server for all of the sites that attach to it.

The channel is the communications path between the server and the field hardware. There are several types of communications paths available but only one type will be built for each panel, unless that panel is using redundant communications, in which case there will be two communications paths for each panel.

The panel is going to be of several types. An example of a panel would be a PW6000 IC and all of its’ down stream IO Boards.

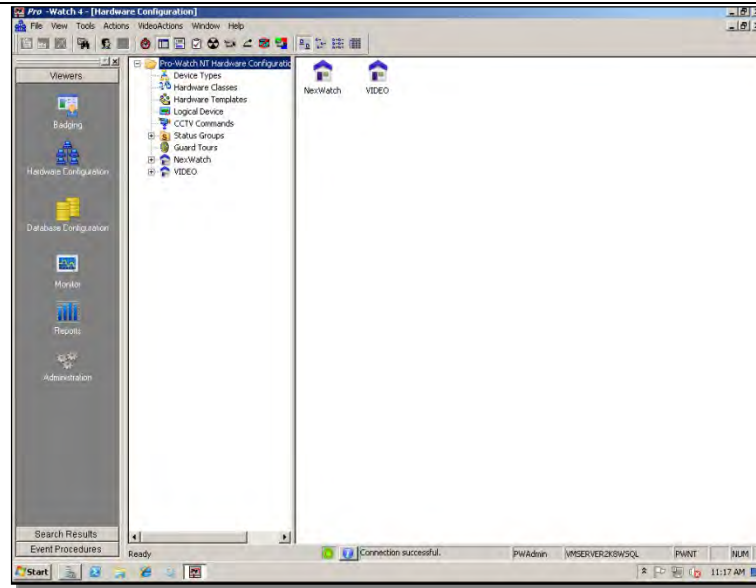

**Site**

Step 1 – To build a Site, right click on one of the existing sites and select “New / Site”.

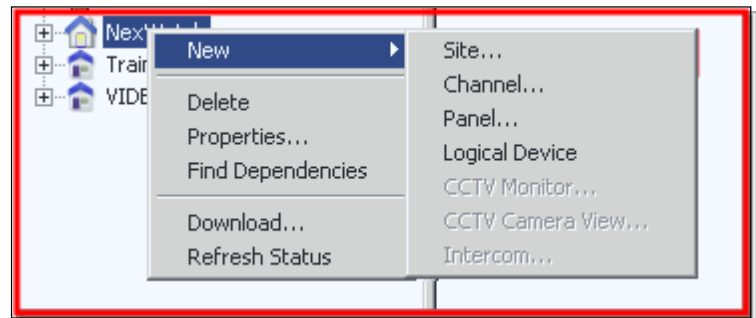
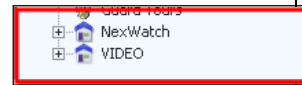

Right Click..., select “New / Site”

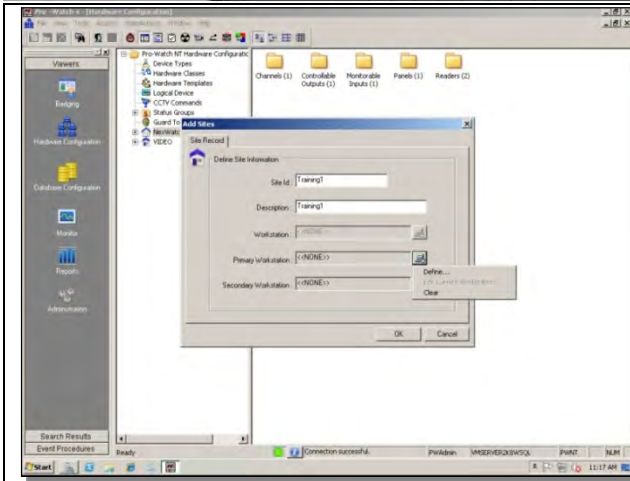

Step 2 – Click the computer icon next to the “Primary Workstation” and choose the server from the list of computers.

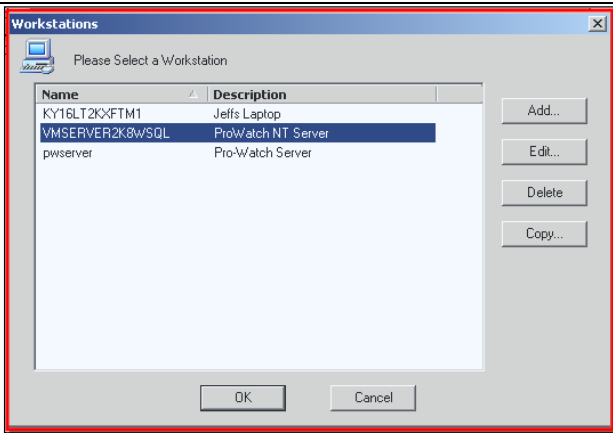
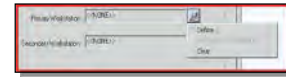

Step 3 – Choose the Pro-Watch server from the list.

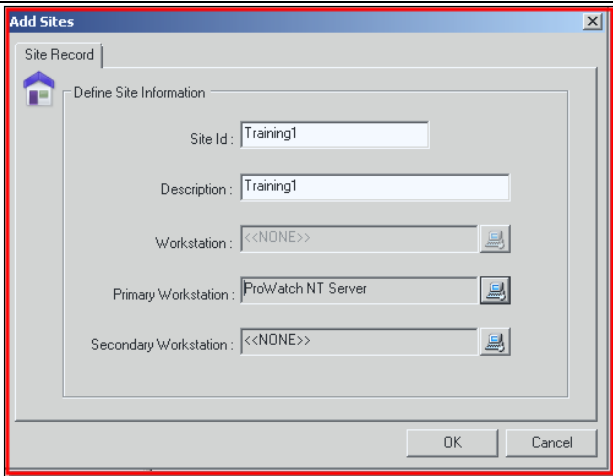

Step 4 - When finished click OK.

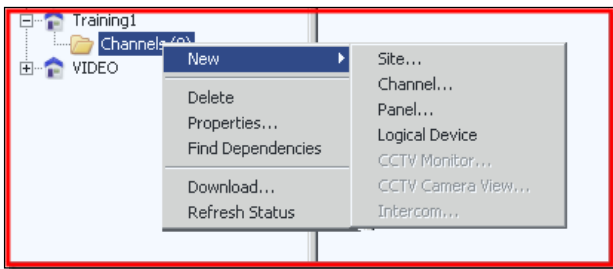

**Channel**

Step 5 - That completes the Site, now right click on the site and select “New / Channel”.

	<p>Step 6 -From the Channel Type drop down list, select the type of field device that this channel is going to connect to. This will determine the communications format.</p>
--	---

For this example select the PW-5000 for communicating to a PW3000, PW5000, PW6000, and a PW6100.



	<p>Step 7 – Click OK.</p>
--	---------------------------

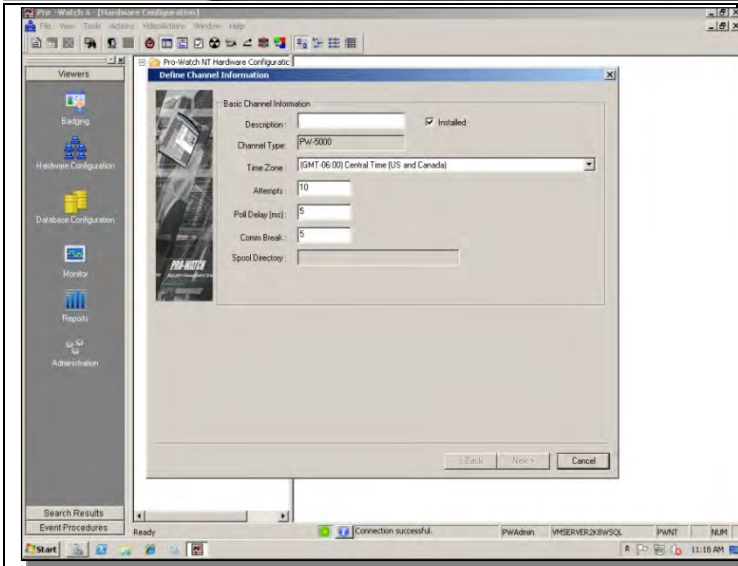

Step 8 – Next give the channel a description. The description should include the panel type that the channel is going to. Example – Building A- PW6000

Click the Next button

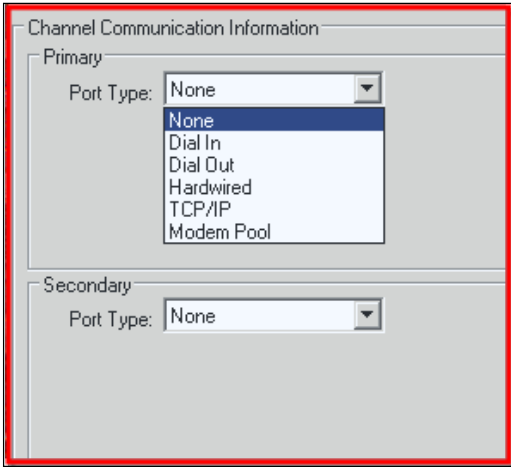

Step 9 – Now in the Port Type drop down, select how you are going to communicate. Our example will be TCP/IP.

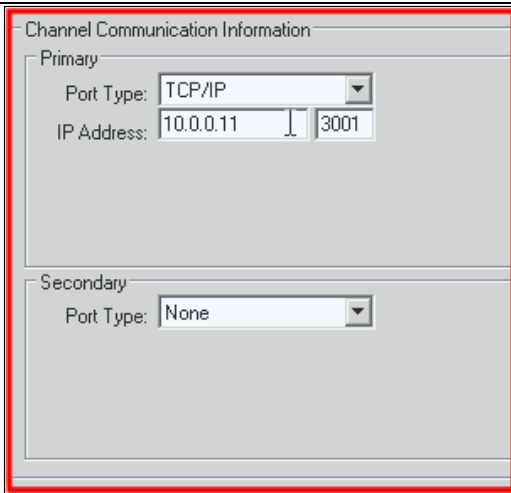

Step 10 – Enter the Panels TCP/IP address and set the default port to 3001.



Step 11 – Click Next. Skip the Encryption setup and click Next again.

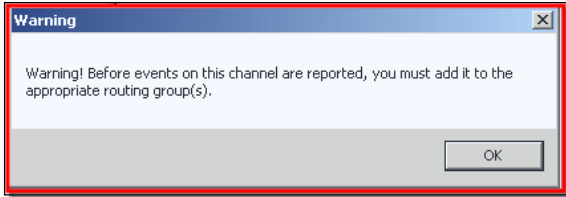
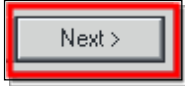

Step 12 – A warning box will appear. Click OK to continue.

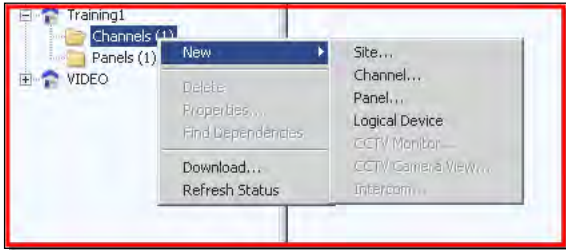

### Panel

Step 13 – Right click on the Channel and select “New / Panel”.

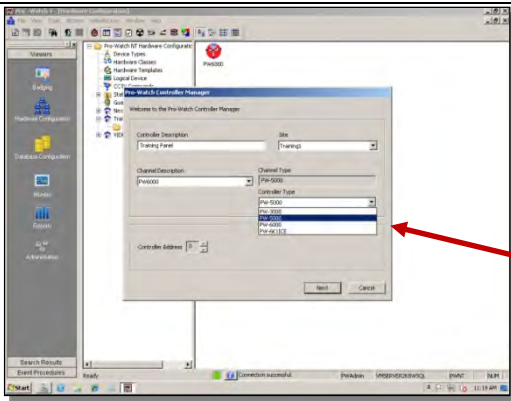

Step 14 – This will open another wizard. Give the panel a name and select the correct Panel Type.

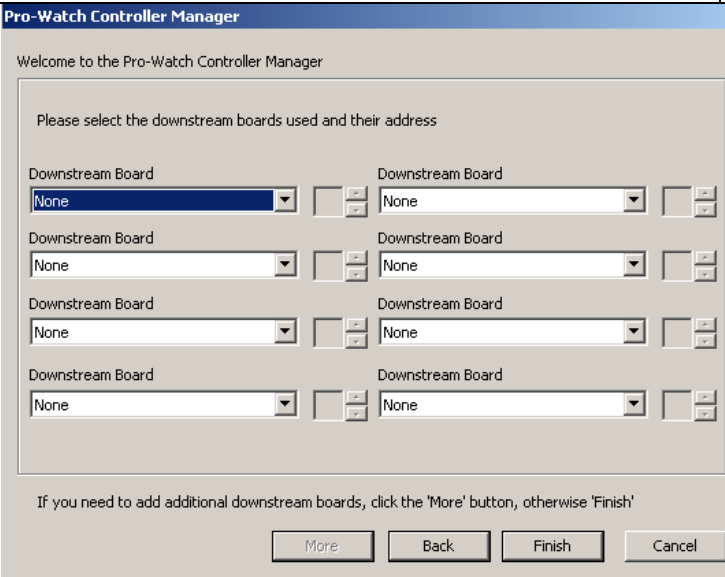
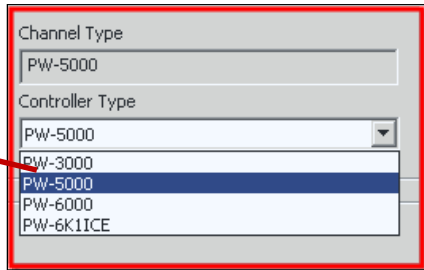

Step 15 – The last step is to indicate the type and address of the IC board’s IO boards. The IO board address is filled in automatically so if you enter the downstream board type for address 0 first, and 1 and so on, then the addresses will not have to be changed. The wizard assumes that you will start with the lowest numbered board.

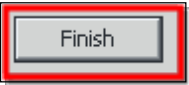
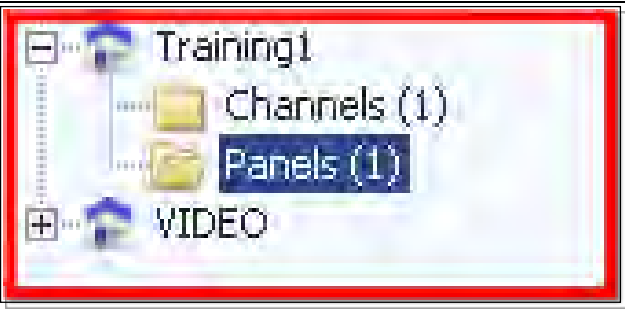
	<p>Step 16 – When you are done click the Finish button.</p>
	<p>Step 17 – You will see a new folder and it will indicate (1) for one panel.</p>
<p>This completes the section on creating a Site, Channel, and a Panel.</p>	

## Lab 4 - Site, Channel, Panel

### Site

1. Sites are found by clicking the Hardware Configuration icon in the viewer bar on the left.
2. A site is indicated by the little house symbol. If you right click any existing site, you will get a menu that allows the user to create a new site.
3. Select one of the existing sites
4. Right Click the Site
5. Select the **New** menu item
6. Click the **Site...** menu item
7. The Site ID is the SQL name so it is limited in characters and can not contain any spaces.
8. Type in a Site ID.
9. The Description is the name you will see in the hardware tree.
10. Type in a Description.
11. Click the icon of a computer on the right of the Primary Workstation text box to browse the list of workstations.
12. Select the **Define...** menu item
13. When the **Workstations** dialog opens, it will be a list of the workstations in the Pro-Watch database.
14. Select the **Primary Server** workstation.
15. Click the **OK** button

### Channel

1. A Channel in Pro-Watch is the path that communications takes from the



- server to the hardware. The channel types are named by the type of equipment they go to. Pro-Watch then knows what format the data will be in. That way Pro-Watch can interpret the data that is being transmitted.
2. To add a channel, select the channel folder in the site you are working with, and then right click it to open a menu.
  3. Next select "New" from the menu, and then select the Channel item from the menu.
  4. Use the dropdown for Channel Type, to find the appropriate one. In this case select the PW5000 channel type. Use the PW5000 even if you are connecting to a PW6000.
  5. Click the **OK** button
  6. Next, give the channel a Description. Remember that there can be multiple channels in this one folder, so a good description is imperative. Call this one Demo Channel.
  7. Use the Time Zone entry box to choose the time zone that the PW panel will be in. Use the Central Time Zone.
  8. Click the **Next >** button to continue.
  9. The drop down contains the possible communications paths, or channels, that can be used with a PW panel. Select the TCP/IP Port Type
  10. There are only two things that you need to know.
    1. What TCP/IP address is the panel going to be set to.  
and
    2. What port will it be communicating through.The port address goes in the second smaller box. Set the Panel Address to the address the instructor told you, and set the port to 3001.
  11. When the port communications are completed, click the NEXT> button to continue.
  12. We are not setting up encryption, so click the NEXT> button again.
  13. We are not putting this panel in a Partition. Click the NEXT> button.
  14. The warning is to remind you that if you have made any custom routing groups before you made this channel, then you will need to add this channel to the ones you have made.
  15. Click the OK button
- This is the End of the Channel LAB.



## Panel

1. The first step is to right click on the channel folder of the Site that this panel will belong to. This will open a menu.
2. Click the **New** menu item.
3. Select the **Panel...** menu item
4. Select the **Site** drop down box, and select the Site that your panel will be in.
5. Select the **Channel Description** drop down box, and pick the channel that was created for this panel.
6. After the channel is selected a new set of options appear. It is the Controller Type option. Here you will select what type of IC board you are going to

- communicate with. In our case it will be the PW6000 type controller.
7. Select the **PW-6000** item
  8. In the Controller Address box enter the PW6000 Communication Address of the IC. This would have been on the on the Host Port menu when logged into the PW6000 IC. The default is 0 in both the IC and Pro-Watch.
  9. In the **Controller Description** text box give this panel a name. Since Pro-Watch will allow duplicate names, you need to develop a naming convention before you start programming so that the user will be able to distinguish which item is which.
  10. Click the **Next** button
  11. This screen allows the user to assign IO, or, downstream boards, to this IC. At present you can only add 8 through the wizard. If there are more then they have to be added one at a time from the panel properties dialog box.
  12. Use the dropdowns to select the type of IO boards, and then select the addresses of them.
  13. After entering and addressing the IO boards, click the Finish button to close the dialog and create the panel.
  14. End of the Adding a PW6000 panel Lab.

## 7 - Logical Devices

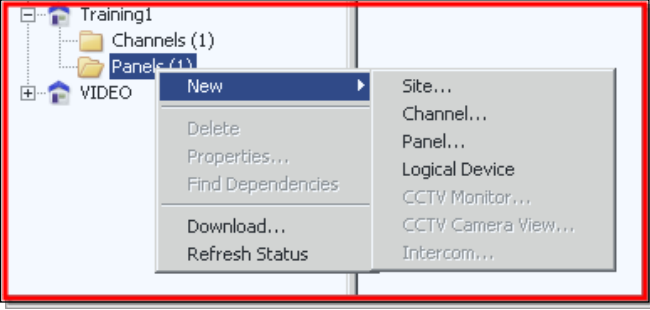
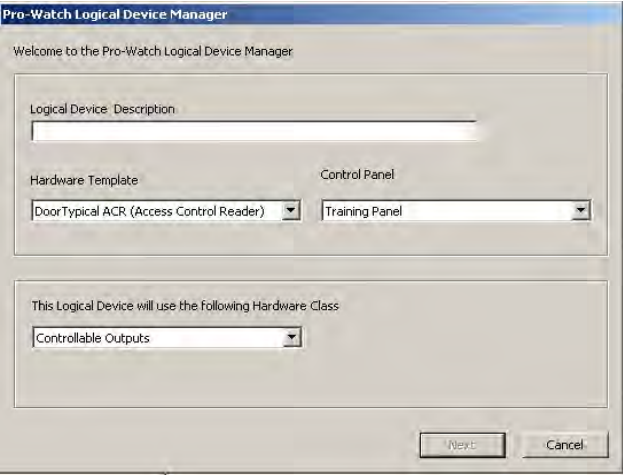
### Adding a reader

	<p>All systems need to have a reader attached. The following is an example of adding a reader to Pro-Watch</p> <p>Right click the panel and select New \ Logical Device.</p>
	<p>The Pro-Watch logical Device Manager will open. This wizard is used to add all of the logical devices.</p> <p>All logical devices are made from a hardware template. A template can contain one or more types of devices. If the device types are part of a normal door configuration then the wizard will pick the default inputs and outputs that are normally associated with a reader. If they are not part of a normal configuration then you will have to add the device types in the way described in the following two sections.</p>
	<p>Step 1 – Give the logical device a meaningful name. It is important to have a naming convention in place before you start to add Logical devices.</p>

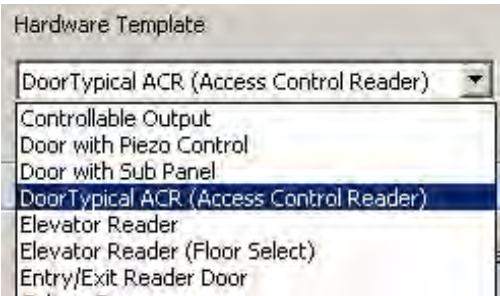
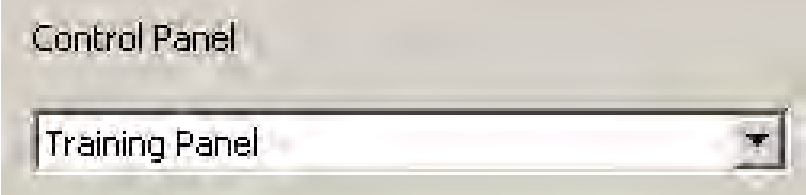
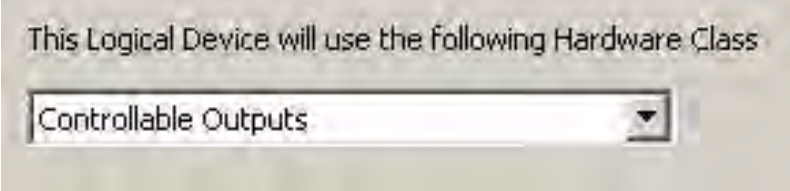
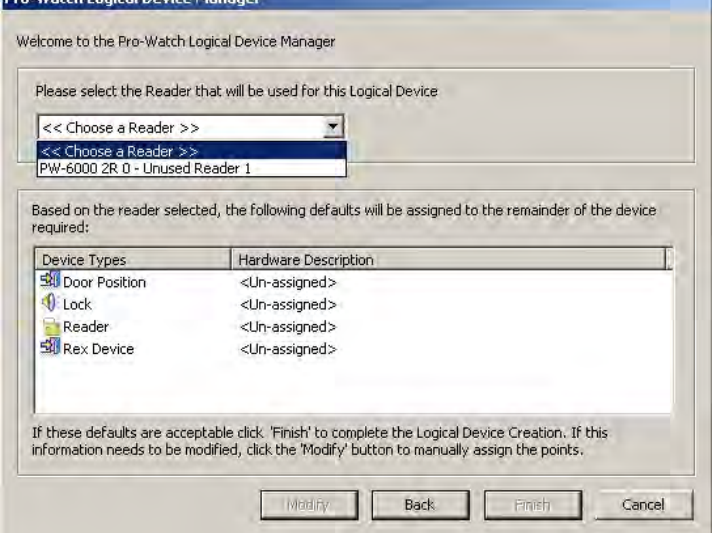
	<p>Step 2 – Select the template that has been created for the type of logical device you are creating.</p>										
	<p>Step 3 – Select the Control panel that the device will be wired to.</p>										
	<p>Step 4 – Select the Hardware class (folder) that the logical device will reside in. The Hardware classes that are in the drop down list were created before starting to create Logical devices. (see Hardware Classes in the Help files)</p>										
 <table border="1" data-bbox="269 1537 912 1705"> <thead> <tr> <th>Device Types</th> <th>Hardware Description</th> </tr> </thead> <tbody> <tr> <td>Door Position</td> <td>&lt;Un-assigned&gt;</td> </tr> <tr> <td>Lock</td> <td>&lt;Un-assigned&gt;</td> </tr> <tr> <td>Reader</td> <td>&lt;Un-assigned&gt;</td> </tr> <tr> <td>Rex Device</td> <td>&lt;Un-assigned&gt;</td> </tr> </tbody> </table>	Device Types	Hardware Description	Door Position	<Un-assigned>	Lock	<Un-assigned>	Reader	<Un-assigned>	Rex Device	<Un-assigned>	<p>Step 5 – The last step is to choose which unused reader port that this reader will be wired to. When you select the port from the drop down, Pro-Watch will fill in the rest of the points for you. After the points show as Assigned, click the Finish button. This will build the Logical Device and close the window.</p>
Device Types	Hardware Description										
Door Position	<Un-assigned>										
Lock	<Un-assigned>										
Reader	<Un-assigned>										
Rex Device	<Un-assigned>										

Finish

### Adding an Output

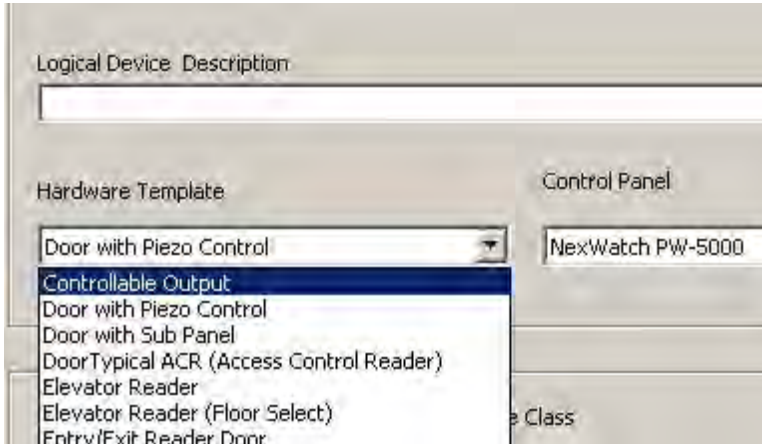

Steps 1-4 are the same to add an output as they are to add a reader. Just be sure to select the correct Hardware Template.

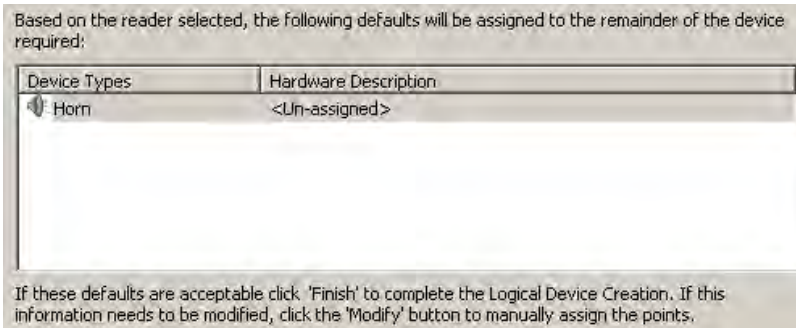

The unassigned output now needs to be assigned to an unused output point on the controller. Click the Modify button and select the unused point you want to assign to this device type.

Modify







The drop down will list all of the unused points.

Finish

Click the finish button to complete the process of creating this logical device.

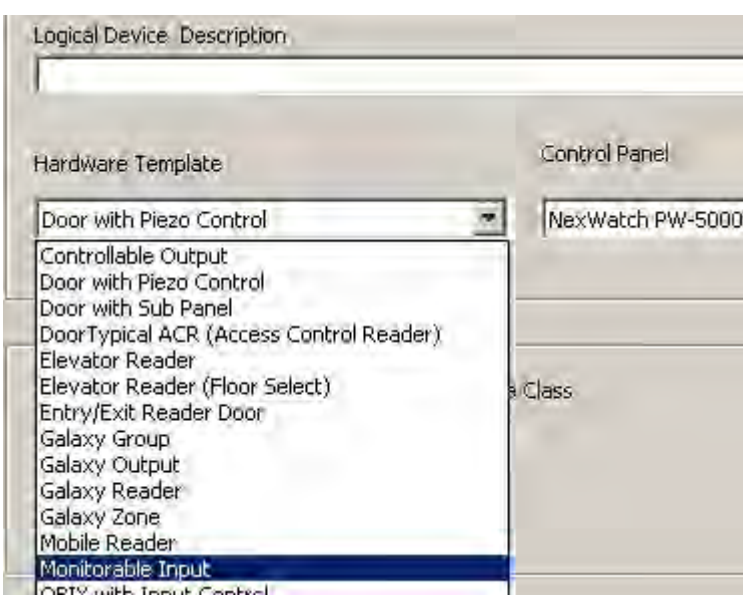

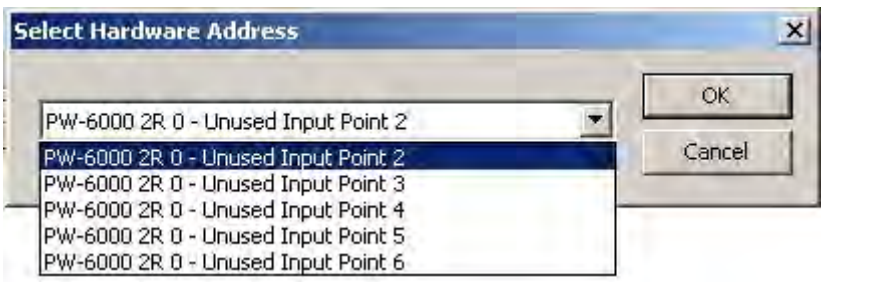
## Adding an Input Point

	<p>The steps to make an input point are the same as an output.</p> <ol style="list-style-type: none"> <li>1. Name the Logical Device</li> <li>2. Choose the Hardware Template</li> <li>3. Select the proper Control Panel</li> <li>4. Assign the unused input point to the device in the template.</li> <li>5. Click the Finish button.</li> </ol>				
<p>Based on the reader selected, the following defaults will be assigned to the remainder of the device required:</p> <table border="1" data-bbox="243 1029 1104 1260"> <thead> <tr> <th>Device Types</th> <th>Hardware Description</th> </tr> </thead> <tbody> <tr> <td>InputPoint</td> <td>&lt;Un-assigned&gt;</td> </tr> </tbody> </table> <p>If these defaults are acceptable click 'Finish' to complete the Logical Device Creation. If this information needs to be modified, click the 'Modify' button to manually assign the points.</p>	Device Types	Hardware Description	InputPoint	<Un-assigned>	<p>Highlight the input point to assign and click the Modify button.</p> <div style="text-align: center;">  </div>
Device Types	Hardware Description				
InputPoint	<Un-assigned>				
	<p>Select the unused input and click the Finish button when all of the devices in the template have been assigned.</p> <div style="text-align: center;">  </div>				

## Lab - 5 Logical Devices

All logical devices have to be created by referencing a panel, and a template. The template you select will determine what device types will be in the logical device. A Logical Device is made by mapping the unused points from the panels IO boards, to the device types in a template. In this case we are going to make a logical device for the lobby door. As with access control doors, the door will have a reader, a lock, a door position switch, and a request to exit button.

1. To create a logical device, select the panel it will be controlled from.
2. Right Click the panel to open a menu.
3. Click the **New** menu item
4. Click the **Logical Device** menu item
5. When the **Pro-Watch Logical Device Manager** dialog opens, give the logical device a meaningful name. Example: Lobby Door
6. Next use the drop down to find the correct template.
7. Select the DoorTypical ACR (Access Control Reader) item
8. From the Control Panel window, use the drop down to select the correct panel.
9. Now select the correct folder. Folders are called, Hardware Classes.
10. Select the **Readers** hardware class.
11. Click the **Next** button

The wizard for making logical devices that have a reader in them is a little different in functionality then other wizards. In the wizard for a logical device with a reader, all you do is choose the reader port that you want to use and the wizard will pick the rest of the points for you.

12. Select the PW-6000 2R 0 - Unused Reader 0 item

The system always chooses the corresponding points in a certain manner, so you know in advance what points will be chosen.

You can always highlight one of the selected points and use the Modify button to select a different unused point.

13. If you are satisfied, click the Finish button.
14. Click the **Finish** button
15. Add three more doors: Rear door, Warehouse Door, Employee Entrance.

That completes the process for creating a logical device for a door with a reader. There are still a couple of settings that need to be optioned that are not taken care of in the template. They are the options that require a time zone, and a card format.

16. To edit the last of the options, double click the logical device for the door.
  17. When the logical device dialog opens, go to the Logical Device Details tab.
  18. Double click the reader.
  19. Go to the Reader Settings tab and notice all the settings here. Set the Strike Time to 3 seconds and the Held Time for 20 seconds.
  20. Go to the Advanced Settings tab. The Override Time Zone is the setting that unlocks the door as per some schedule. Pick the Time Zone that controls that schedule. Example: Choose the 8am-5pm M-F time zone.
- End of LAB

## Inputs

1. To add a Monitorable input point right click the panels to open a menu.
2. Click the **New** menu item
3. Select the **Logical Device** menu item
4. When the **Pro-Watch Logical Device Manager** dialog opens, give the logical device a meaningful name.
5. Then select the Template that you are going to use.
6. Select the **Monitorable Input** item from the list.
7. Now select the panel that will control the input.
8. The last thing to do on this screen is to pick the folder that you want the input to reside in. The folders are called Hardware classes.
9. Select the Monitorable Inputs item
10. Click the **Next** button
11. Either select the Input point and click Modify or double click the input point.
12. Use the drop down list to pick the unused input point on one of the panels IO boards. Be careful that you pick the correct point because it is easy to get confused as to which point is which.
13. Click the **OK** button
14. Click the **Finish** button

You can now see that a new Hardware Class has been added and it contains our new Monitorable input point.

To view or edit the options for an input point, locate the logical device, double click it, or, right click it and select properties. Choose the Logical Device details tab. Now double click the input point that you wish to edit. These are the options for an input point. No matter how the input is used, these are the only options.

## Output

1. Right Click the Panel
2. Click the **New** menu item
3. Select the **Logical Device** menu item
4. When the **Pro-Watch Logical Device Manager** dialog opens, give the logical device a meaningful name. \*\*\*(Remember that Pro-Watch does not

require unique names so if you are not careful you could end up with multiple devices with the same name.)

5. Use the Hardware Template drop down to choose the appropriate template. Select the Controllable Output item.\*\*\*(No logical device can be made without using a template.)

6. Lastly select the Hardware Class, or folder, that this logical device will reside in. Select the Controllable Output item.

7. Click the **Next** button

8. Now you need to map an unused output to this device type. Double click the horn to choose an available point.

9. Select the PW-6000 2R 0 - Unused Output Point 5 item

10. Click the **Finish** button

11. Select the Controllable Outputs Hardware Class. You can see now that your output has been created.

12. Double click the logical device.

13. Go to the Logical Device Details tab and you will find the output.

14. Double click the output.

15. Set the Pulse Time to 4 seconds.

16. Click OK.

End of Lab

## 8 - PW panel Options

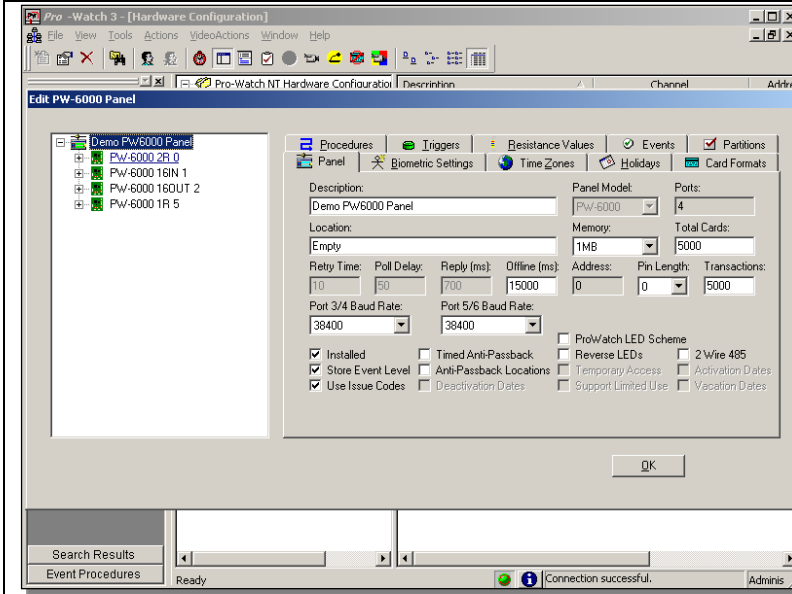

To open the options for a panel, either right click the panel, and select Properties, or, double click the panel.

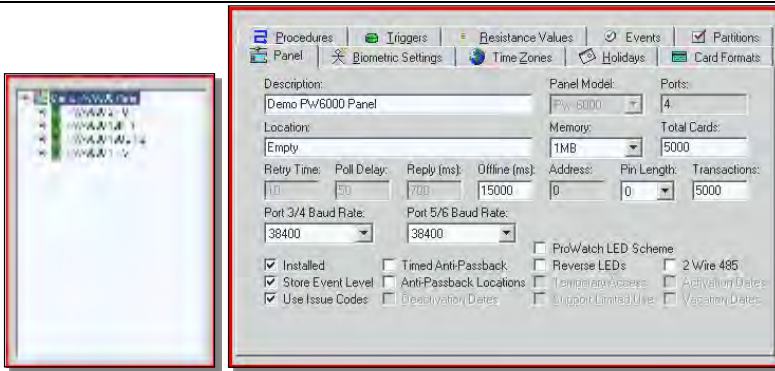

The panel option view has two parts. On the left is a listing of all of the parts of the panel. It includes the IC board, the IO boards, and all of the inputs, outputs, and reader ports on the IO boards.

On the right is a window that has the options for those parts. As you highlight something on the left the options for it appear on the right.

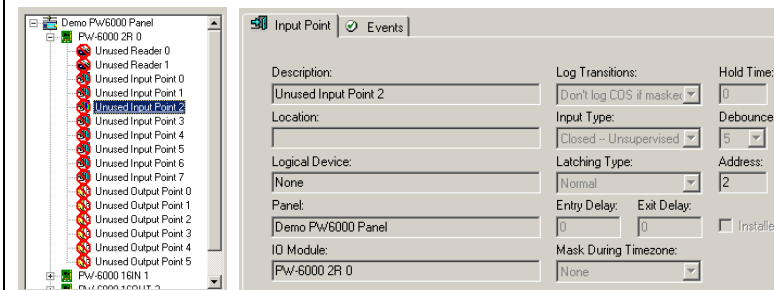

If you expand the plus sign on the IO board then you can see the inputs, outputs, and readers. Highlighting them will bring up their options.

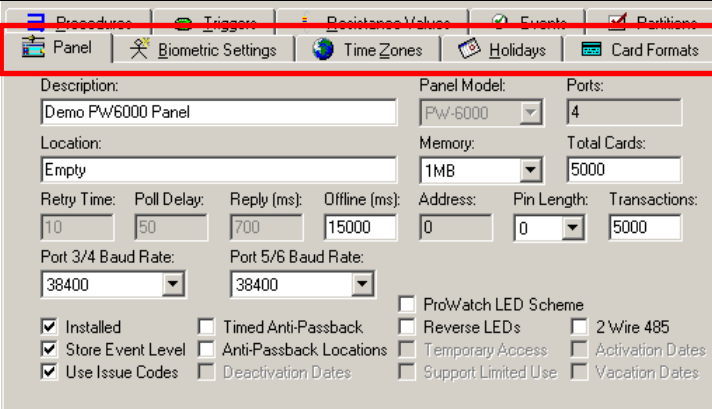

The bottom row of tabs MUST be filled out. The Panel tab is unique in that any changes on this tab have to be “Initial-ized” into the panel. This removes all of the current options so after the panel is initialized, it must be downloaded.

The Biometric tab is used for the hand geometry readers and has a separate document so it will not be covered here.

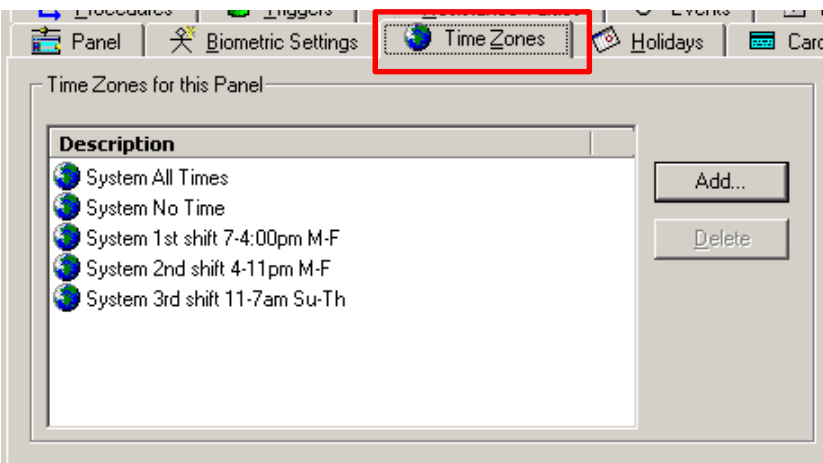

On the Time Zone tab you need to add ALL of the time zones that this panel will need to operate. Include any time zones that the Logical Devices will need and ALL of the time zones that the clearance codes will need.

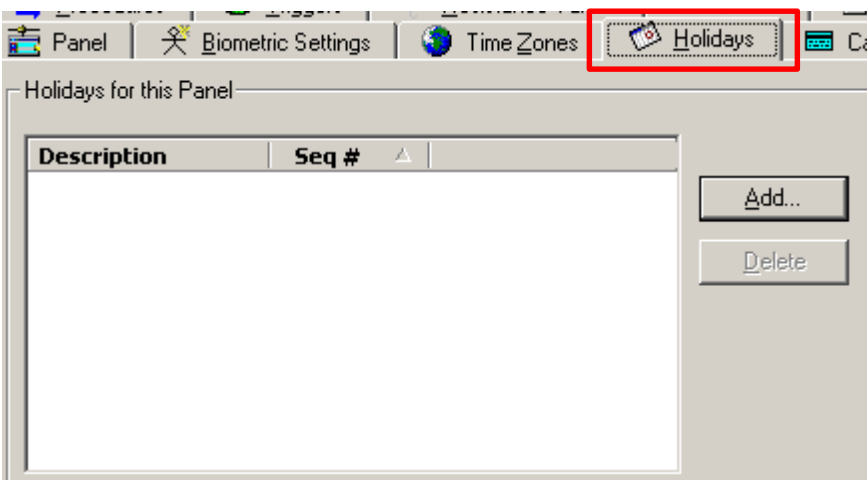

The Holidays tab also needs all of the dates that the panel needs to recognize as Holidays.



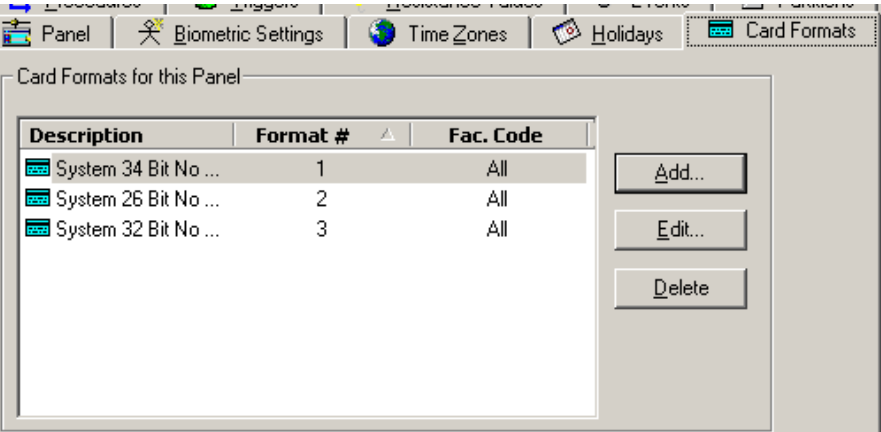

Description	Format #	Fac. Code
System 34 Bit No ...	1	All
System 26 Bit No ...	2	All
System 32 Bit No ...	3	All

The Card Formats Tab MUST include any card formats that this panel will be using. It also is where you list the Site codes (facility Codes) that the cards in this panel have. The total number of formats and site codes cannot exceed eight (8).

## Lab 6 - Panel Options

### Time Zones

1. Select the Demo PW6000 Panel item
2. Right Click the **Demo PW6000 Panel** item
3. Select the **Properties...** menu item
4. The Edit PW-6000 Panel dialog opens
5. Select the **Time Zones** tab
6. Click the **Add...** button
7. Select the 8am - 5pm M-F time zone.
8. Click the **OK** button
9. Click the **Add...** button
10. You can add more than one time zone at a time to the panel Time Zone list.
11. Hold down the Ctrl button and select the last two time zones.
12. Click the **OK** button

### Holidays

13. Select the **Holidays** tab
14. Click the **Add...** button
15. Holiday Drop Down box.
16. Select the **Define...** menu item
17. The **Holiday List** dialog opens
18. Select the **July 4th** item
19. Click the **OK** button
20. Click the **OK** button
21. Click the **Add...** button
22. Holiday Drop Down box.
23. Select the **Define...** menu item

24. The **Holiday List** dialog opens
25. Select the New Years Eve and Day item
26. Click the **OK** button
27. Click the **OK** button

### Card Formats

28. Select the **Card Formats** tab
29. Click the **Add...** button
30. Click the Card Format Drop Down box.
31. Select the **Define...** menu item
32. The **Card Formats** dialog opens
33. Select the 32 bit with Facility item
34. Click the **OK** button
35. Select the **Facility Code** text box
36. Enter a sample Facility Code.
37. Click the **OK** button

You cannot have a card format with No Facility code and the same card format with a facility code in the unless the formats are used on different readers.

38. Select the System 32 Bit No Facility item
  39. Click the **Delete** button
  40. Click the **Add...** button
  41. Click the Card Format Drop Down box.
  42. Select the **Define...** menu item
  43. The **Card Formats** dialog opens
  44. Select the 32 bit with Facility item
  45. Click the **OK** button
  46. Select the **Facility Code** text box
  47. Enter a sample Facility Code
  48. Click the **OK** button
  49. Click the **OK** button
- End of Options LAB

## 9 – Status and Downloading

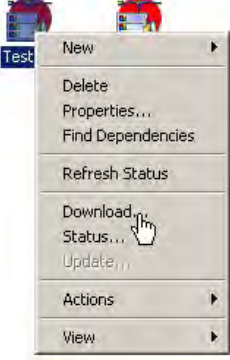
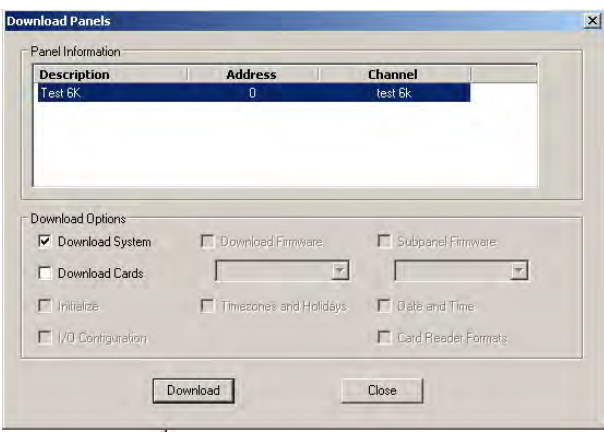
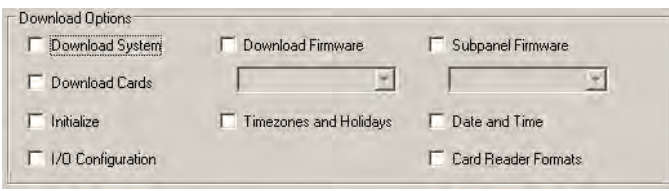
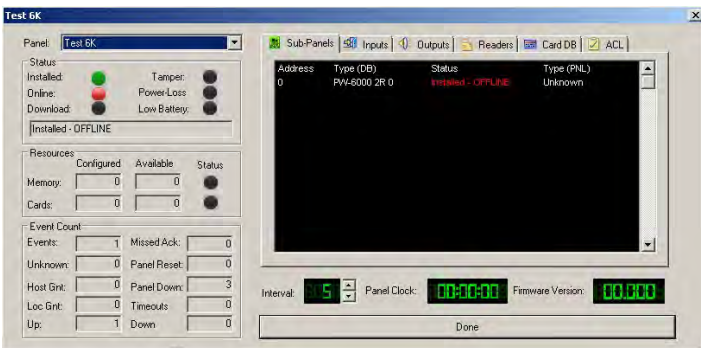
	<p>When you right click on a panel, the menu will display “Download”, and “Status”. Open the Status window first and move it out of the way. Next, right click and select Download.</p>
	<p>In the download window you will see that “Download System’ is selected. This will download everything to the panel except cards. Selecting Download Cards will download the cards. You can select either one singly or both together. De-selecting Download System will allow you to download only the things you need</p>
	<p>If this IC board is new or you just replaced one, it is a good idea to select “initialize” by itself and click OK. This will wipe out any old settings that are in the panel’s record. You can then download system.</p>
	<p>The Status window lets you use the status of different devices on a panel, as well as control them. The clock at the bottom is displaying the time that the IC board thinks it is.</p>

## Lab - 7 Status and Downloading

1. Right Click the Panel icon.
2. Select Status from the menu.
3. Pull the Status window to the lower portion of the screen.
4. Leaving the Status window open, right click the Panel icon again and select  
Download from the menu.
5. Deselect Download System
6. Select Initialize and click OK
7. When the panel comes back on line(about 2 min.), repeat steps 4 and 5, but  
this time just select OK.

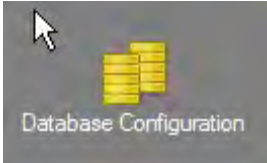
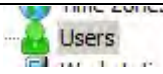
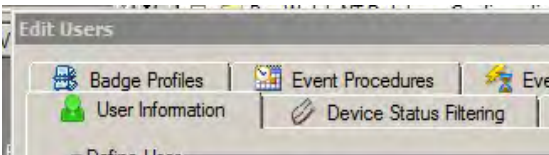
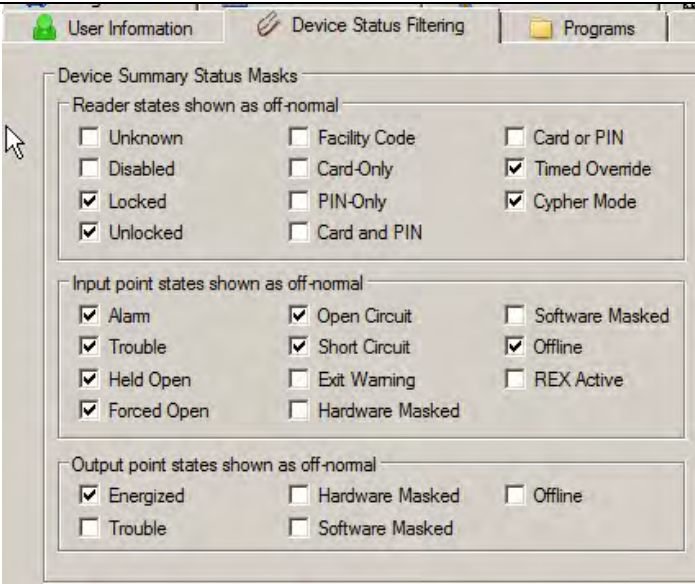

End of Lab

## 10 - Device Status Filtering

 <p>Database Configuration</p>	<p>All of the icons for the logical devices will be a green certificate. This is because the state filtering is turned off. To turn it on click Database Configuration.</p>
 <p>Users</p>	<p>Now select the Users database.</p>
 <p>Edit Users</p> <p>Badge Profiles   Event Procedures   ...</p> <p>User Information   Device Status Filtering</p>	<p>The second tab on the bottom row is the one you need. It is called "Device Status Filtering". This is the only tab in Users that doesn't show up in Classes.</p>
 <p>User Information   Device Status Filtering   Programs</p> <p>Device Summary Status Masks</p> <p>Reader states shown as off-normal</p> <p><input type="checkbox"/> Unknown    <input type="checkbox"/> Facility Code    <input type="checkbox"/> Card or PIN</p> <p><input type="checkbox"/> Disabled    <input type="checkbox"/> Card-Only    <input checked="" type="checkbox"/> Timed Override</p> <p><input checked="" type="checkbox"/> Locked    <input type="checkbox"/> PIN-Only    <input checked="" type="checkbox"/> Cypher Mode</p> <p><input checked="" type="checkbox"/> Unlocked    <input type="checkbox"/> Card and PIN</p> <p>Input point states shown as off-normal</p> <p><input checked="" type="checkbox"/> Alarm    <input checked="" type="checkbox"/> Open Circuit    <input type="checkbox"/> Software Masked</p> <p><input checked="" type="checkbox"/> Trouble    <input checked="" type="checkbox"/> Short Circuit    <input checked="" type="checkbox"/> Offline</p> <p><input checked="" type="checkbox"/> Held Open    <input type="checkbox"/> Exit Warning    <input type="checkbox"/> REX Active</p> <p><input checked="" type="checkbox"/> Forced Open    <input type="checkbox"/> Hardware Masked</p> <p>Output point states shown as off-normal</p> <p><input checked="" type="checkbox"/> Energized    <input type="checkbox"/> Hardware Masked    <input type="checkbox"/> Offline</p> <p><input type="checkbox"/> Trouble    <input type="checkbox"/> Software Masked</p>	<p>Place check marks in the status changes that you want to show up when you look at the icon. Be selective and do not check all of the status boxes in the top box. Doing so will make your reader ALWAYS show as "Off Normal".</p> <p>When finished, click the OK button to close the Users window.</p>



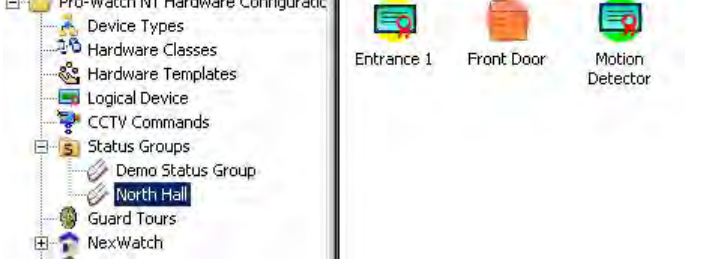
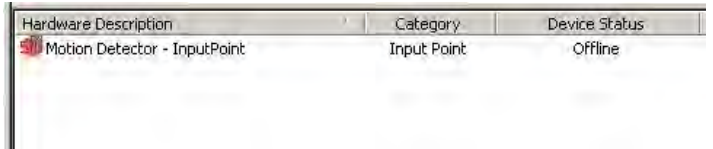

	<p>When you click OK, the window will close and a new Status group icon will be added to the list.</p>						
	<p>Click on Hardware Configuration and expand the + sign next to Status Groups. All of the groups will be listed and you can select the one you want to look at.</p>						
	<p>Once the Status Group has been selected all of the Logical Devices in the group will be displayed. Click one time on the logical device of your choice and the actual components of that logical device will be displayed at the bottom of the screen.</p>						
 <table border="1"> <thead> <tr> <th>Hardware Description</th> <th>Category</th> <th>Device Status</th> </tr> </thead> <tbody> <tr> <td>Motion Detector - InputPoint</td> <td>Input Point</td> <td>Offline</td> </tr> </tbody> </table>	Hardware Description	Category	Device Status	Motion Detector - InputPoint	Input Point	Offline	<p>The components will be listed at the bottom with the current status of each device listed to the right.</p>
Hardware Description	Category	Device Status					
Motion Detector - InputPoint	Input Point	Offline					

## Lab 8 – Status Groups

1. To make a status group, select Database Configuration from the viewer bar on the left.
2. Select the Status Groups item
3. Right click the window on the right to open a menu.
4. Select the New Status Groups... menu item
5. When the **Add Status Groups** dialog opens, give the Status Group a meaningful name.
6. To add logical devices to the group click the Add button.

There are two ways to select the logical devices that you want in the group. You can highlight one of the logical devices and click the ok button, or, since all of the systems logical devices are listed in this window, hold down the Ctrl key and highlight all of the logical devices you want by clicking them with the mouse.

7. Highlight one, and click the ok button.
  8. Now try the other way.
  9. Click the **Add...** button
  10. Now hold down the Ctrl key and select the Logical devices that you want in the group.
  11. Click the **OK** button
  12. When you have finished adding logical devices, click the OK button to save the Status Group.
- Now that you have created the group, close all the open windows, and then reopen the Hardware Configuration tree by clicking the icon in the viewer bar. We do this because the new group will not show up in the tree until you refresh the view by closing it and reopening it.
13. Click the **Close** button
  14. Click the **Close** button
  15. Now reopen the hardware tree by clicking the Hardware Configuration icon.
  16. When you click the Status Groups item, your new Status Group will be visible.
  17. Select the new group item.
- You select the logical device in the top half of the window and the condition of the device types in it are displayed in the lower window.
18. Select the Logical Device with a reader in it. item

## 12 - Routing Groups

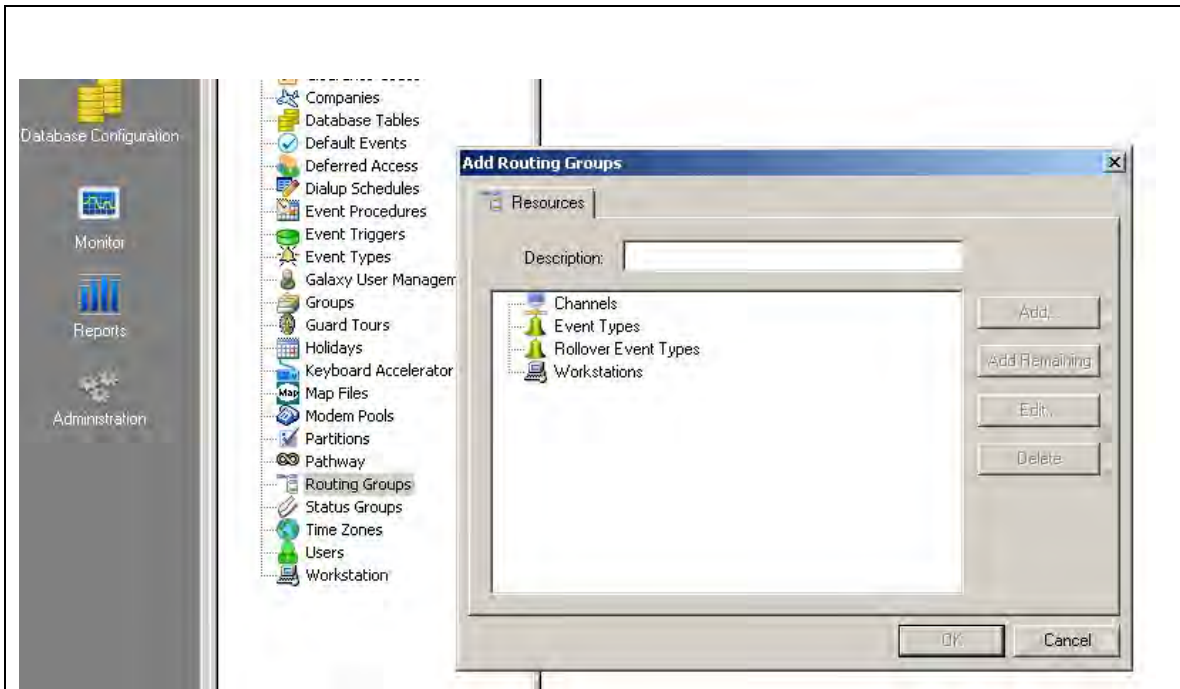

Routing groups are used to push the correct events to the workstations of your choice. This is used to allow certain users to see only the events that you want them to see. Under Database Configuration you will find the menu item called Routing Groups. A Routing Group determines “which Channels, send which events, to which workstation”. Once a Routing group is built it can then be assigned to either a Class or a User. This will replace the default Routing Group. From then on the users that have the new routing group will only see the events from the selected channel.

### 13 - Clearance Codes

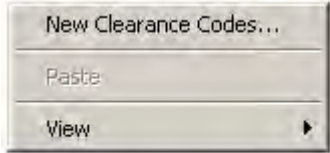
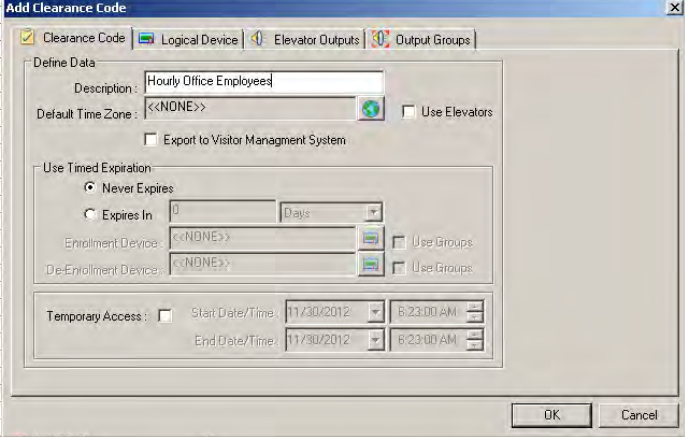
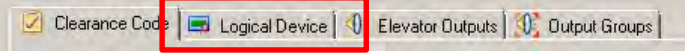
	<p>Clearance codes determine where and when an access credential is valid. To make a clearance code, click Database Configuration and then click Clearance Codes from the list.</p>
	<p>Right click the right hand window and select New Clearance Codes.</p>
	<p>When the Add Clearance Code window opens give the clearance code a meaningful name. Remember that you are allowed to duplicate names so be sure that the name reflects the type of employee clearance and the location. An example would be: North Admin Hourly Employees or Denver Managers. This way you have where the clearance code will be valid and the type of employee that will have this clearance code assigned to their credentials.</p>
	<p>Next click the Logical device Tab.</p>

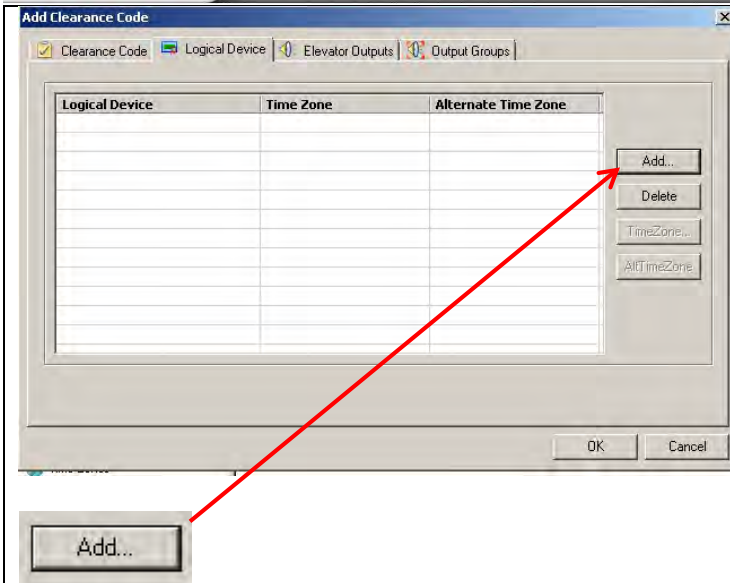

On this tab you are going to pick the readers that will be assigned and the times that a credential will be valid at that device.

Click the Add button.

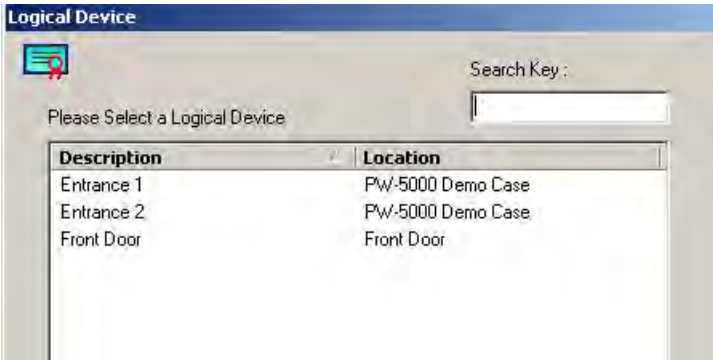

From this window you will highlight the reader or readers that you want to add to this clearance code.

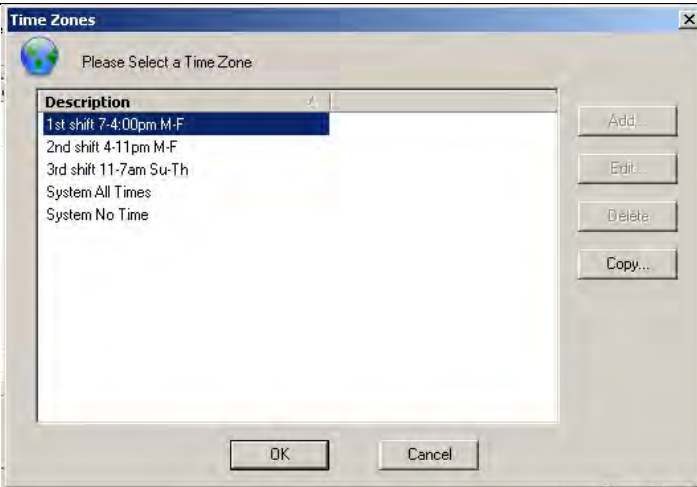

If you highlight more than one reader using the Ctrl key, then all of the readers will be assigned the same time zone.

If the time zone you want is not shown, then you didn't add the time zone to the panels that control the readers.



Select the time zone for this reader.

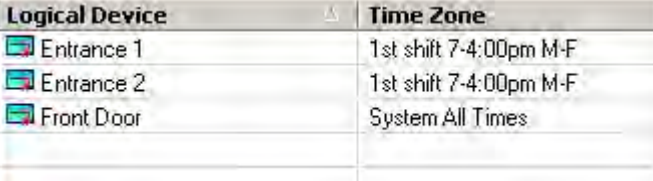

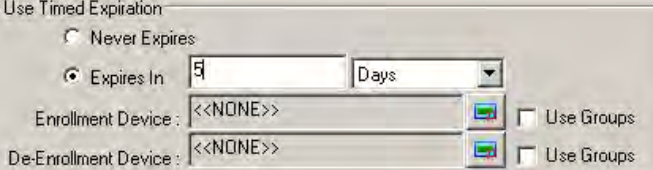
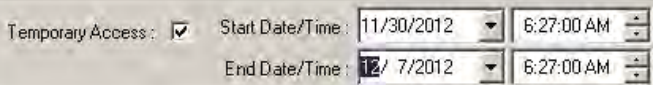

 <table border="1"> <thead> <tr> <th>Logical Device</th> <th>Time Zone</th> </tr> </thead> <tbody> <tr> <td>Entrance 1</td> <td>1st shift 7-4:00pm M-F</td> </tr> <tr> <td>Entrance 2</td> <td>1st shift 7-4:00pm M-F</td> </tr> <tr> <td>Front Door</td> <td>System All Times</td> </tr> </tbody> </table>	Logical Device	Time Zone	Entrance 1	1st shift 7-4:00pm M-F	Entrance 2	1st shift 7-4:00pm M-F	Front Door	System All Times	<p>After you select the readers and the time zones the window will display them.</p>
Logical Device	Time Zone								
Entrance 1	1st shift 7-4:00pm M-F								
Entrance 2	1st shift 7-4:00pm M-F								
Front Door	System All Times								
 <p>Hourly Office Employees</p>	<p>Click OK and a new icon will be displayed. This is a permanent clearance code.</p>								
 <p>Use Timed Expiration</p> <p><input type="radio"/> Never Expires</p> <p><input checked="" type="radio"/> Expires In: <input type="text" value="5"/> Days</p> <p>Enrollment Device: &lt;&lt;NONE&gt;&gt; <input type="checkbox"/> Use Groups</p> <p>De-Enrollment Device: &lt;&lt;NONE&gt;&gt; <input type="checkbox"/> Use Groups</p>	<p>There are two other types of clearance codes. The first is a Timed Expiration clearance code. It starts when it is enrolled and only lasts x number of Min, Hours, or Days. It then stops working.</p>								
 <p>Temporary Access: <input checked="" type="checkbox"/></p> <p>Start Date/Time: 11/30/2012 6:27:00 AM</p> <p>End Date/Time: 12/7/2012 6:27:00 AM</p>	<p>The second type is a Temporary Access clearance code that has a start and end date sometime in the future. The start date and time have to be greater than the current date and time</p>								



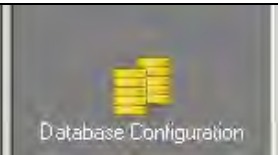
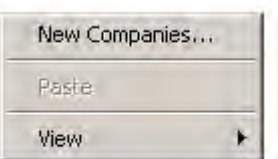
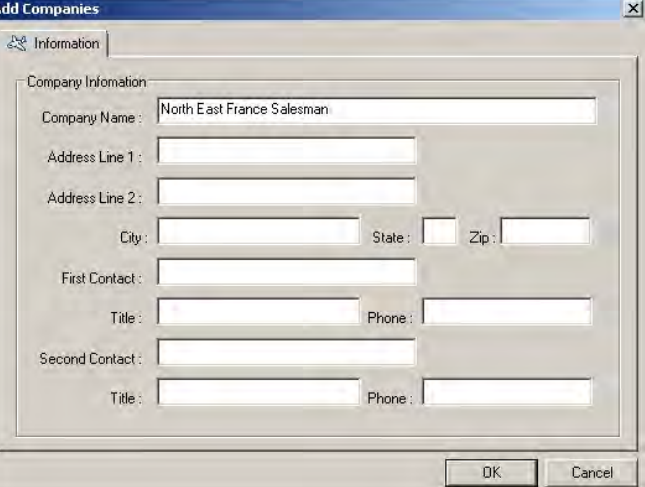

# 14 - Companies

Companies are simply Clearance code groups. In Pro-Watch you must use the company function since it is a required field. It makes sense then to build your companies correctly and save yourself some time while using the system. Some people will make empty Companies and assign them. Then go further into badging and manually add the clearance codes they want. This just wastes time.

Think of it like this: You are sitting at a badging station for a large multi-national corporation and a person comes to you for a badge. You ask them what their job title is, and they reply North East France Salesman. Would you know what doors to give them access to? But if someone had built a company (clearance code group) called North East France Salesman that already contained all of the Clearance codes, then all you would have to do is assign the Company and Pro-Watch would automatically associate the correct clearance codes with their badge.

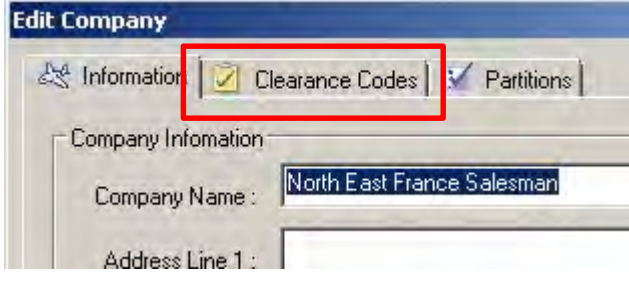
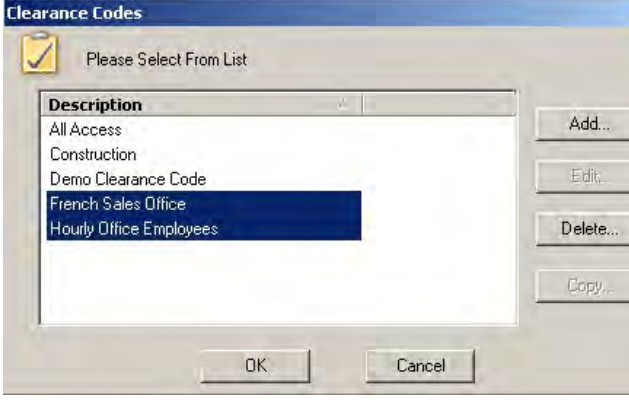
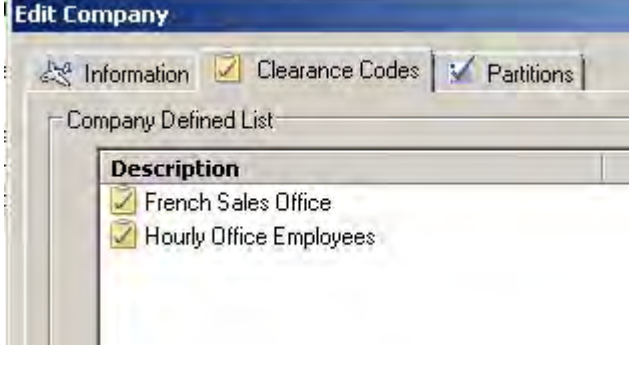
	<ul style="list-style-type: none"> <li>Classes</li> <li>Clearance Codes</li> <li><b>Companies</b></li> <li>Database Tables</li> <li>Default Events</li> </ul>	<p>Go to Database configuration and select Companies.</p>
		<p>Right click in the right hand window and pick New Company from the menu.</p>
		<p>When the Add Companies window opens, give the company a meaningful name and click OK to close the window. You cannot complete the company until you close it and reopen it.</p>
		<p>Double click the new icon.</p>

	<p>Now there is a new tab called Clearance Codes.</p> <p>Select it.</p>
	<p>Click the Add button and it will open a screen with all of the possible clearance codes listed. Select the ones that you want to be part of this company and click the OK button.</p> <p>You can use the Ctrl key and select more than on company.</p>
	<p>You can now see the clearance codes that are part of the company. These are the clearance codes that will be assigned to the persons credentials when they are added to Pro-Watch.</p>
	<p>Click the OK button.</p>

## Lab - 9 Clearance codes and Companies

### Clearance Codes

1. Clearance Codes in Pro-Watch are used to determine where and when an access card is valid. A single Pro-Watch Corporate edition system can become very large and cover anywhere that a network or phone line can connect to. There can literally be many sites, with hundreds of doors with readers. Combine that with the many ways that employees are allowed to move through the facilities, and you have a very large task in creating and maintaining clearance codes.
2. To make a clearance Code, click the Database Configuration icon in the viewer bar on the left. 

3. When the **Database Configuration** window opens, click the Clearance Code item in the list. 

4. There is a default **All Access** Clearance code provided in the system. This clearance code cannot be edited, and contains all the readers, with 24 hour, 365 day access.

5. To add a new Clearance Code, right click the right hand window.

6. Right Click the **New Clearance Code...** menu item

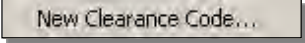

7. It is very important that the naming of the clearance codes be given some thought. Remember, there could be hundreds of different ways that employees and visitors are allowed to use the facilities, and the name you give the clearance code needs to describe the usage.

8. Name the Clearance Code, Managers.

9. After naming the clearance code, select the **Logical Device** tab.

10. To start adding readers, Click the **Add...** button



11. Select the Lobby Door reader.

12. Click the **OK** button



13. Note:...This list is not a list of all of the time zones in the system. It is a list of the time zones that were added to the panel that this reader attaches to. If the time zone you are looking for is not in this list, then you have not put it in the panels Time Zone tab list.

14. Select the **System All Times** item

15. Click the **OK** button



16. Add all four doors with the Systems All Times, time zone.

17. When you have finished adding the readers and the time zones, click the OK button to save this clearance code.

18. Right Click the right hand window.

19. Select the New Clearance Code... menu item



20. Name the Clearance Code, Employees Hourly.

21. Select the Logical Device tab

22. Click the **Add...** button

23. Select the **Lobby Door** item

24. Click the **OK** button

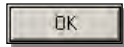

25. Select the 8am-5pm M-F time zone.



26. Click the **OK** button



27. Click the **Add...** button



28. Add the other three doors with the same Time zone: 8am-5pm M-F

29. Click the **OK** button

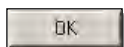

30. The first clearance code that we made used the system all times time zone for the readers. This one uses the 8am-5pm Monday through Friday time zone for both readers. The time

zones do not have to be the same for all readers. Each reader can have a different time zone associated with it.

31. Make an Hourly Supervisor Clearance code. With 8am-5pm M-F and Holidays on all doors except the lobby door. Make it System All Times.
32. Make a Salesman Clearance code with 8am-5pm on the Rear Door only. There will be no other doors in this Clearance Code.
- 33.

### Companies

34. Click the Database Configuration icon in the viewer bar on the left.
35. Select Companies, from the list of databases.
36. Right Click the right hand window to open a menu.

37. Click the **New Company...** menu item

A rectangular button with a light gray background and a thin border, containing the text "New Company..." in a standard sans-serif font.

38. Give the Company a meaningful name. Use the name Managers.

39. You have to close and reopen the company in order to add clearance codes to it.

40. Click the **OK** button

41. Double-click the **Managers** company.

A rectangular text box with a light gray background and a thin border, containing the text "Managers" in a standard sans-serif font.

42. Select the Clearance Codes tab

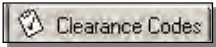
A rectangular tab with a light gray background and a thin border, containing a small icon of a document with a checkmark and the text "Clearance Codes" in a standard sans-serif font.

43. Click the **Add...** button

A rectangular button with a light gray background and a thin border, containing the text "Add..." in a standard sans-serif font.

44. You can Double-click the **Managers** item, or highlight it and click the OK button.

45. We are only adding one clearance code to this company.

46. Click the OK button.

47. Click the **OK** button



48. Repeat the process for the Hourly Employees company.

49. Right Click the window

50. Select the **New Company...** menu item



51. Name the company Hourly Employees.

52. Click the **OK** button



53. Now reopen the company by Double-clicking the **Hourly Employees** item



54. Select the Clearance Codes tab

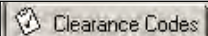

55. Click the **Add...** button



56. Double-click the **Employees Hourly** item

57. Click the **OK** button



58. Make another one for the Hourly Supervisors. Duplicate the previous steps and use only the Hourly Supervisors clearance code.

a. Make a fourth Company.

59. Right Click the window.

60. Select the **New Company...** menu item



61. Call the company Sales Force.



62. Click the **OK** button



63. Double-click the **Sales Force** Company

64. Select the Clearance Codes tab

65. Click the **Add...** button

66. Double click the Employees Hourly clearance code.

67. Click the **OK** button



68. Click the **Add...** button



69. Now add a second clearance code. Select the **Salesmen** clearance code.

70. Click the **OK** button



71. Click the **OK** button

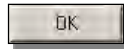

72. End of Lab

# 15 - Badging

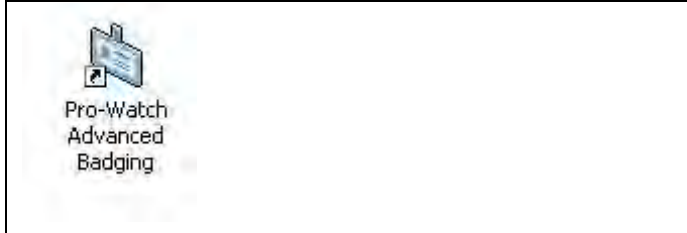

To start the Pro-Watch Advanced Badging application, double click on the Pro-Watch Advanced Badging icon from the windows desktop.

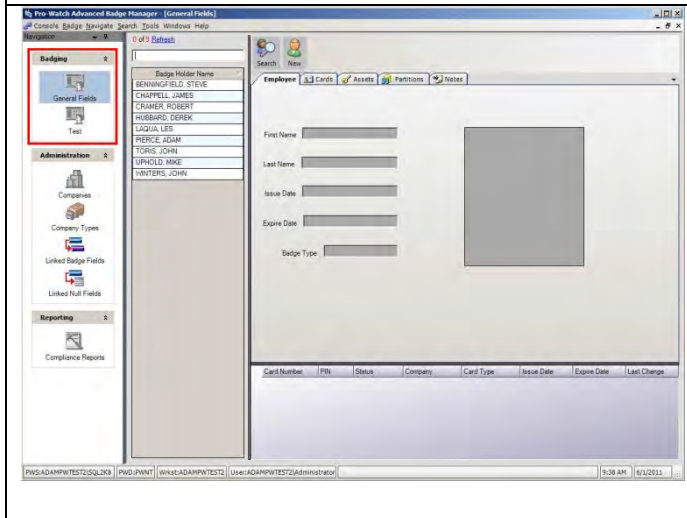

In Pro-Watch Advanced Badging the different badge profiles granted to the user are all available so the user can switch between badge profiles.

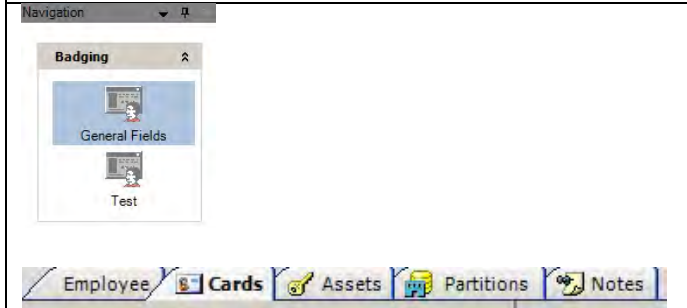

Once a badge profile is selected the badge holder tabs assigned to that badge profile are displayed.

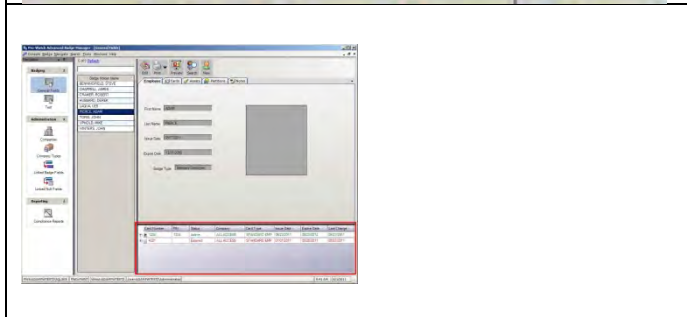

The cards are listed at the bottom of the screen except they are now color coded.

- Green for active cards
- Red for inactive cards

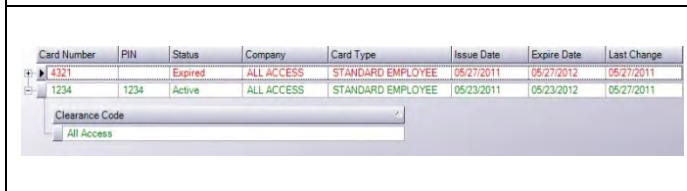

The user may also expand the plus sign and view the clearance codes assigned to the cards.

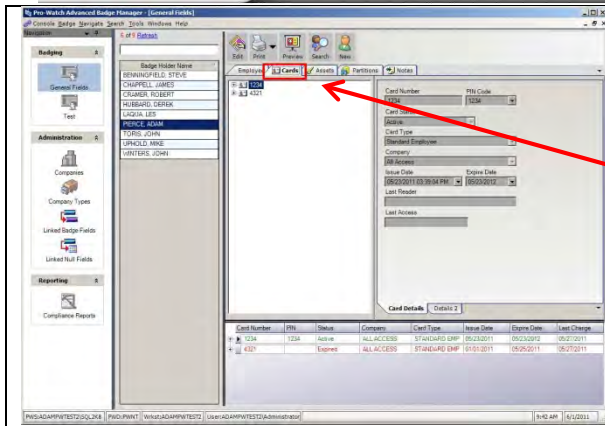

Pro-Watch Advanced Badging also features a new tab containing all of the card information.

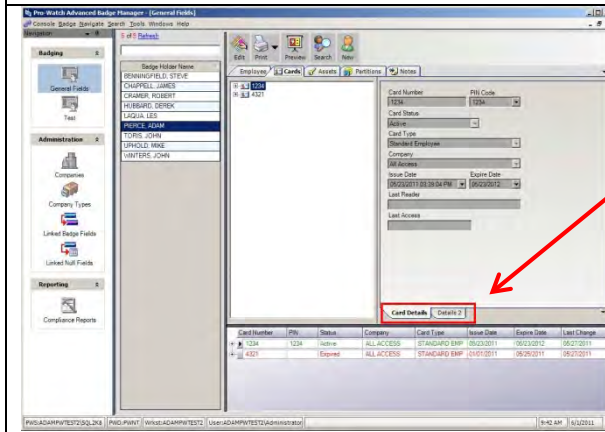
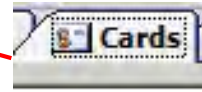

All of the card options are available on two sub tabs.

See the following Tab Details.

Card Number: 1234    PIN Code: 1234

Card Status: Active

Card Type: Standard Employee

Company: All Access

Issue Date: 05/23/2011 03:39:04 PM    Expire Date: 05/23/2012

Last Reader: [Empty]

Last Access: [Empty]

Card Details    Details 2

Card Number: 1234

Trace Card     ADA

PIN Exempt     VIP

0    User Level

Parade Text: [Empty]



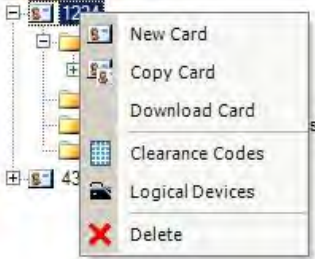
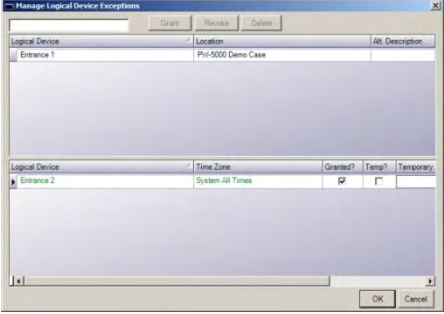
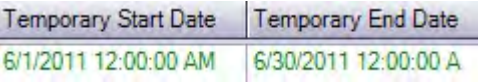
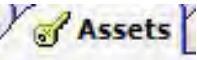
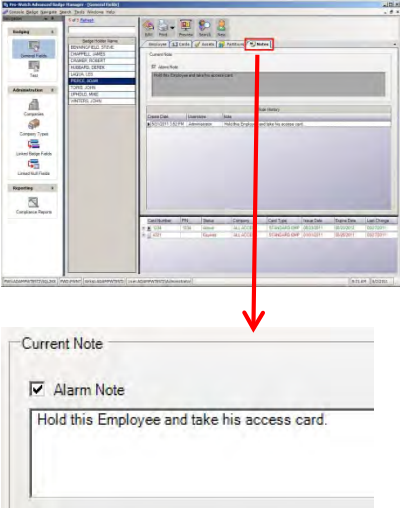

Last Print Date: [Empty]    Print Count: 0

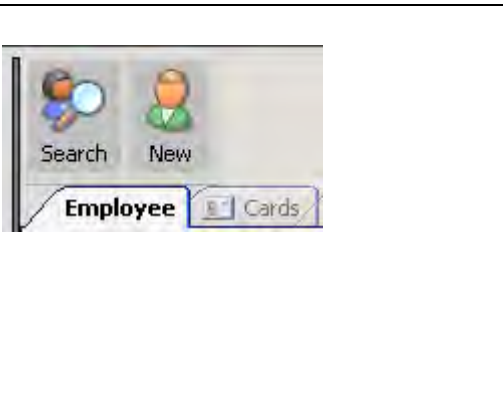
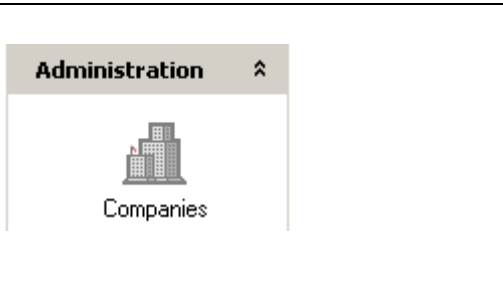
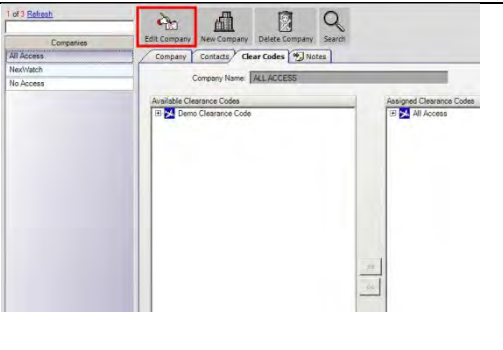
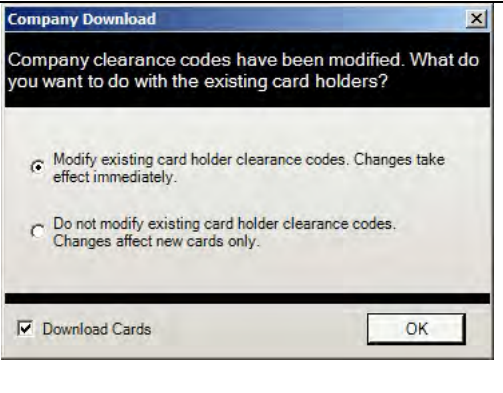
Card Details    Details 2

	<p>There is also an edit button at the top of every screen so that making changes is easy.</p>
	<p>While editing a card the user may right click on the window opening a menu. This menu allows the user to add a new card, copy or download a card, delete a card, and assign clearance codes.</p>
	<p>Clicking on the logical devices item, the user can grant or revoke access to individual logical devices that are not in the cards clearance codes.</p>
	<p>These custom changes are for this card only. The changes can be scheduled to become active or inactive without further notification by utilizing the temporary start date and temporary end date fields.</p>
	<p>Brass Keys has been changed to Assets and can now be used to include anything assigned to the badge holder.</p>
	<p>Notes about the badge holder can be entered just for record purposes or can be entered for notification purposes.</p>

	<p>Notes can be designated as alarm notes. Any notes designated as alarm notes will display the note when the badge holder's record is selected by a user within Pro-Watch Advanced Badging.</p>
	<p>Searching can be done directly from within Pro-Watch Advanced Badging. Every field in the badge record is a searchable field. Searches can be single or multiple fields, as well as single or multiple tabs. The search feature is a quick way to locate badge holders with similar fields without running a report.</p>
	<p><b>Companies</b> Pro-Watch uses the companies feature to assign clearance codes. The companies are available directly from Pro-Watch Advanced Badging.</p>
	<p>The clearance codes associated with the company may be changed by using the edit option.</p>
	<p>After editing a Company and then saving it, Pro-Watch Advanced Badging will ask if the user wants to update the cards and/or download changes to the panels.</p>

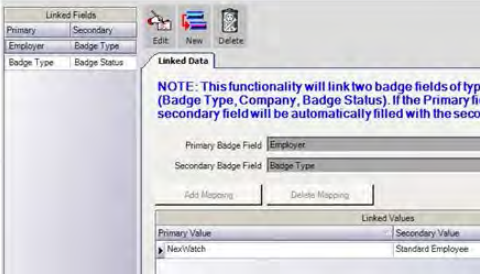

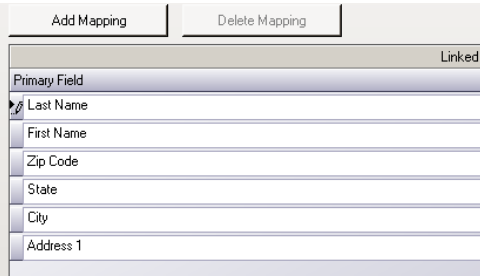
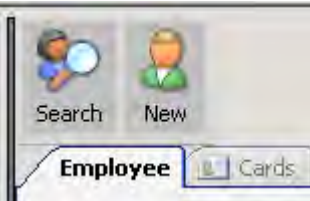
 <p>Company Types</p>	<p><b>Company Types</b> is a grouping feature for companies. This feature is useful for organizing the companies within Pro-Watch for reporting and batch modification functions.</p>
 <p>Linked Badge Fields</p>	<p><b>Linked Badge Fields</b> allows users to setup conditions and have the system fill in fields based upon the condition set in the primary badge field.</p>
	<p>In this example a condition is set that says “if” the Primary Badge Field, “Employer”, is set to “Nexwatch”, “Then” set the Secondary Badge Field, “Badge Type”, to “Standard Employee”.</p> <p>Many of these can be setup to help speed up the filling in of data.</p>
 <p>Linked Null Fields</p>	<p><b>Linked Null Fields</b> is a feature that says: If the user fills out one field, then the user must fill out the field that is linked to it.</p>
	<p>In this example if the user fills out the Last name field, then the user must fill out the Address 1 field. If the user fills out the Address 1 field, then the user must fill out the City field, and so on. This is forcing the user to create a complete record.</p>
	<p><b>Batch modify</b> – Use the search feature to search for all of the badge holders who have the same field.</p> <p>In our example the field we need to change is the name of the Division they work for.</p>



Search for all of the badge holders who have the Honeywell Security name.

When the search completes the user has the ability to modify all of the returned records at the same time by using the Batch Modify feature.

Select Tools then Batch Modify.

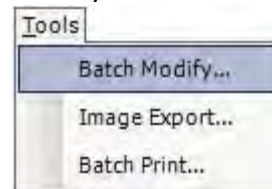

Badge Field	Action	Value	Card Status
Division	Update	HSG	N/A

- Choose the “Division” badge field.
- Fill in the new value of “HSG” and then click on the Add to List option.
- Numerous different field changes can be added to the list of things to be updated.

- When the user clicks OK to initiate the batch modification process the system will indicate the number of records that will be updated. Click the Start button to begin the modification.
- Division is now updated to HSG on all records that were Honeywell Security.

# 16 - Compliance Reports - See Compliance Reporting Guide for more info

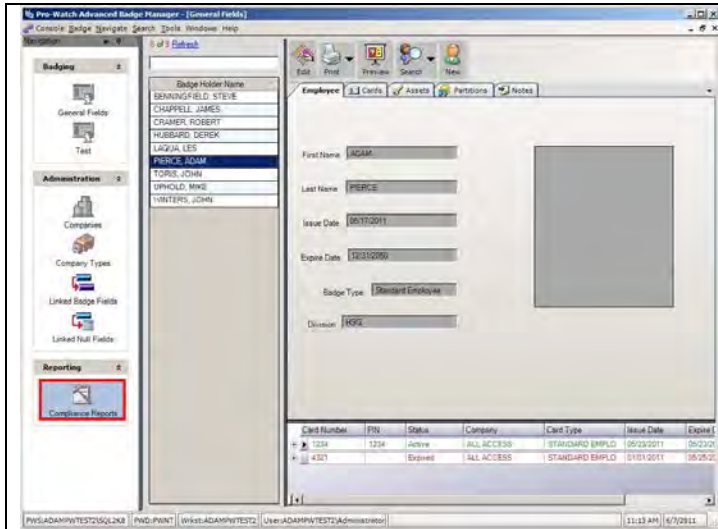

The Compliance Reporter engine is accessible directly from Pro-Watch Advanced Badging.

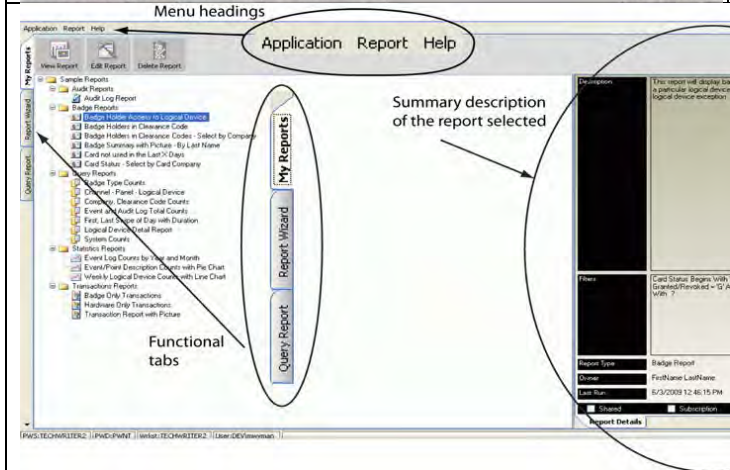

The opening screen has four main areas:

- Menu bar at the top
- Side tabs--Query Report, Report Wizard, and My Reports
- Left-side display area
- Right-side display area

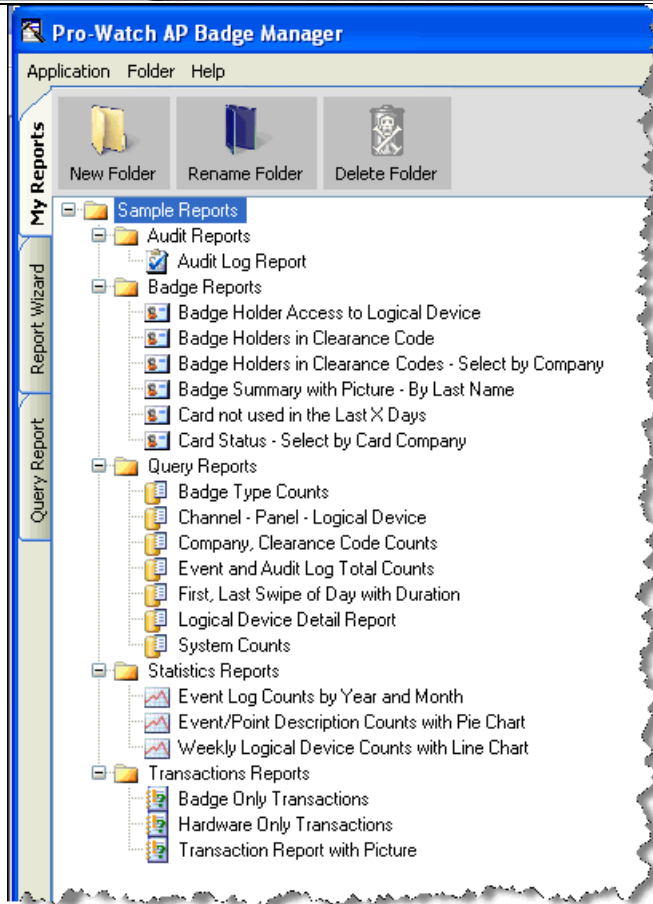

The check box for Sample Reports that is available during the Install will add these reports to the My Reports tab.

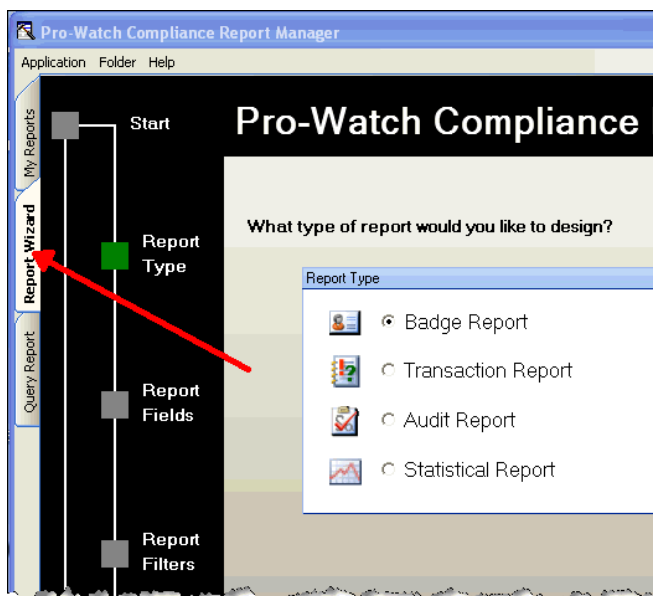

To use the Report Wizard:  
 1. Click the **Report Wizard** tab to view the opening **Report Wizard** screen.

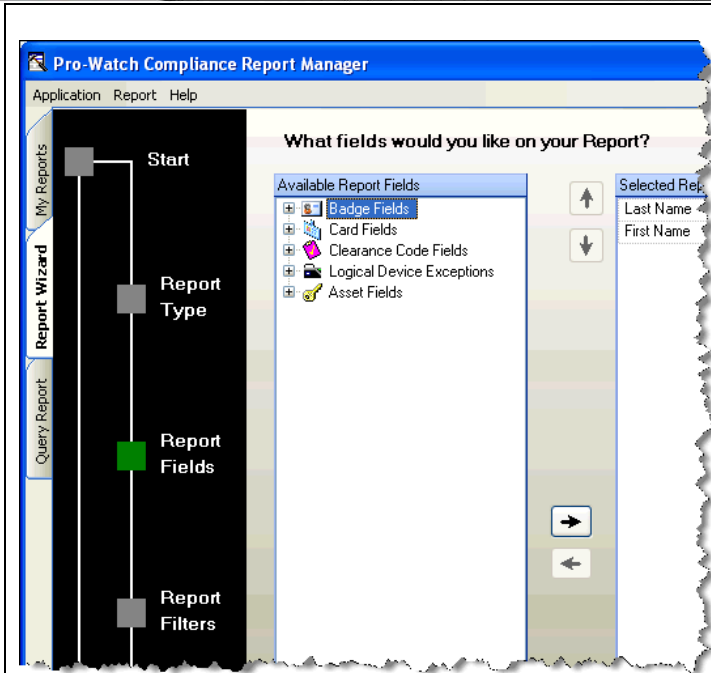

2. Select the type of report you want to create and click **Next** to view the screen that lists the fields available for the report type you selected.

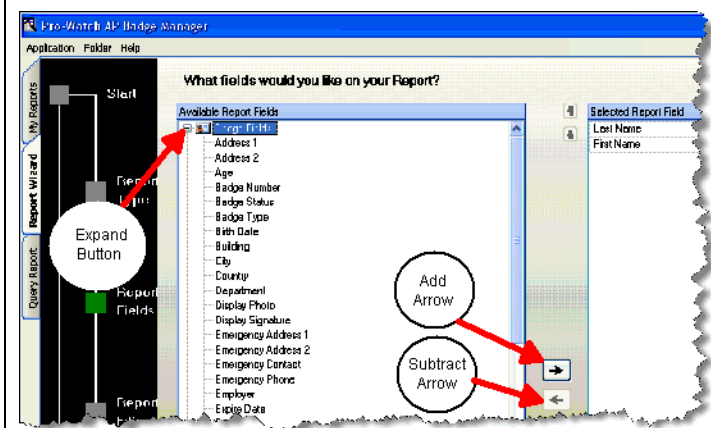

3. Click the expand button next to the type of fields you want to display. The following figure shows an abbreviated view of the Badge Fields expanded.

4. To select a field to display on your report, you can either:

- click to highlight the field name, then click the “add” arrow to add the field to the list in the right-hand box (highlight and click the “subtract” arrow to move the field back to the Available Report Fields column), OR
- double-click the field name to add it to the list in the right-hand box, OR
- click the field name once and drag it to the right-hand box.

	<p>5. Repeat the selection process for any Event Log fields, Card fields, or Area fields you want to include in your report.</p> <p>6. When you have selected all the fields you want in your report, click <b>Next</b> to display the filter fields screen.</p> <p>7. Enter the fields you by which you want to filter. Note that the “Add New Filter” link at the top of the screen enables you to create additional filters.</p>
	<p>8. Click <b>Next</b> to display the <b>Report Title and Description</b> screen.</p> <p>9. Enter the report title and description and select the appropriate Report Options and Report Data radio buttons described in the following table:</p> <p>10. Click <b>Finish</b> to display your customized report.</p>

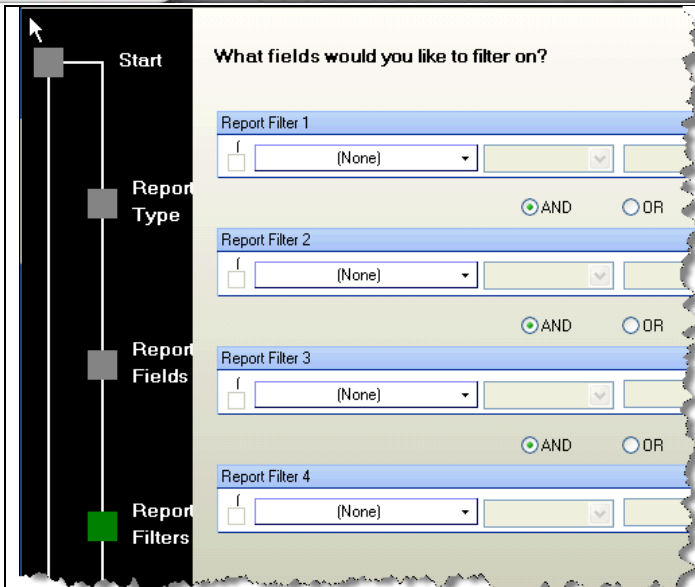

### Using one Filter

After selecting all of the fields you want, click Next to open the filter screen.

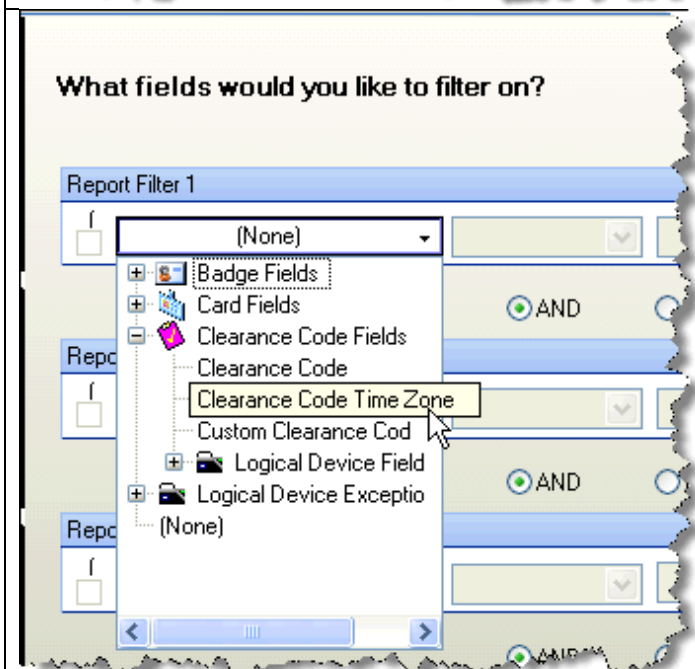

From the drop-down list for the first element of Report Filter 1, select the first element. Note that the operation field becomes active.

Note the two kinds of checkboxes at the ends of the Report Filter line--parentheses and question mark. Since this procedure configures only one filter, leave the parentheses checkboxes blank. Select the question-mark checkbox if you want to be able to change any of the filter elements before the report runs.



- Select the parentheses checkboxes (to enclose the filter) only when the report has more than one filter.
- Select the question-mark checkbox when you want the Compliance Report Manager to prompt you before running the report. The prompt enables you to change any of the filter elements before the report runs.

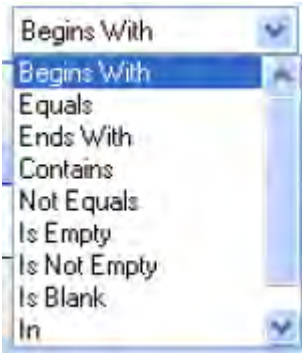

	<p>Select the operator of you want.</p>
---	---

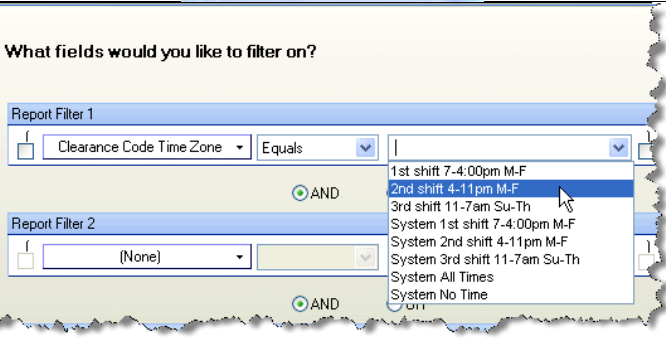
	<p>From the drop-down list for the second element of Report Filter 1, select the value you want in order to complete the filter.</p>
---	--

**Note:** For each filter you select, the corresponding types of the filter appear after the filter operation. For example, when you select **Clearance Code Time Zone** as a filter and specify an operation, the third field is automatically filled with a list of time zones. When you select **Clearance Code** and specify a filter operation, the third field is automatically filled with a list of available Clearance Codes, and so on.

Click **Finish** to accept the filter. The Compliance Report Manager generates a list of all employees whose Clearance Codes are assigned the 2nd shift Time Zone. This is a subset of all employees in the database.

### Using Two Filters

To generate a report with two filters, follow these steps:

1. Open the Report Wizard and follow the steps given in the preceding section, Since this procedure configures more than one filter, be sure to “enclose” the filter with parentheses by selecting the parentheses checkboxes at the ends of the Report Filter line.
2. Select **AND** between Report Filter 1 and Report Filter 2.
3. Follow the steps given in the preceding section to configure the second filter. Remember to select the parentheses checkboxes. The resulting **Report Filter** screen should look like this:

See next page.

What fields would you like to filter on?

Report Filter 1

Clearance Code Time Zone ▾ Equals ▾ 2ND SHIFT 4-11PM M-F ▾

AND  OR

Report Filter 2

Badge Type ▾ Equals ▾ CONTRACTOR ▾

Click **Next** to assign a title and description to the report. Click **Finish** to complete the report.

## Runtime Filter

You can also designate a filter as a runtime filter—that is, a filter that must be applied whenever you run the report. Whenever you try to run a report that has a runtime filter on it, you will be prompted to input a filter value before you can run the report. To designate a runtime filter, select the checkbox under the question mark at the far right of the Report Filter box.

## In/Not In Filter

In addition to the filtering already described, the Compliance Report Manager provides another operation, In/Not In, for grouping multiple instances of a field into one filter. The In/Not In operation applies to fields that have multiple Pro-Watch elements, such as Logical Devices, Companies, Time Zones, Channels, etc. The operation enables you to select, in the second filter element, more than one element to filter on.

For example, to see who has access to a particular door and/or a second door, select **Logical Device** for the first element, select **In** as the operation, and in the second element box click the Query Items box to display all the Logical Devices. Select the two doors as the fields you want to designate as the filter options. When you click **Next** or **Finish**, the report shows all personnel who can access either one or both of these logical devices.

What fields would you like to filter on?

Clear All Items box Query Items box

Report Filter 1

Logical Device ▾ In ▾

AND  OR

To use the In operation for a filter:

1. Click the drop-down list for the first element of Report Filter 1 and select a field with multiple selections as the first element.
2. Select In for the operation. The boxes for **Query items** and **Clear all items** appear in the second element field.
3. Click the **Query items** box to display the **Query [Field]** box.

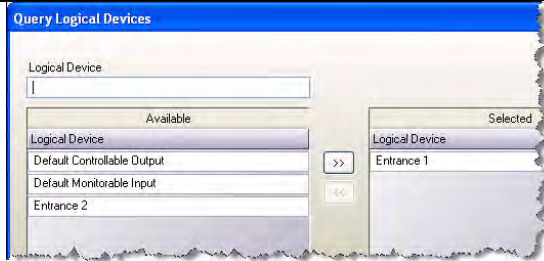

4. In the **Query [Field]** box, select the devices in the **Available** box that you want to use and move (using arrows or double-clicking) them to the **Selected** box.
  5. Click **OK** to return to the **Report Filters** screen.
  6. Click **Next** or **Finish** to display the report on the Report Viewer screen.
- Use the Not In filter to exclude instances of a field from a report. For example, to see who can access all doors except the two selected doors, select **Not In** as the operation.

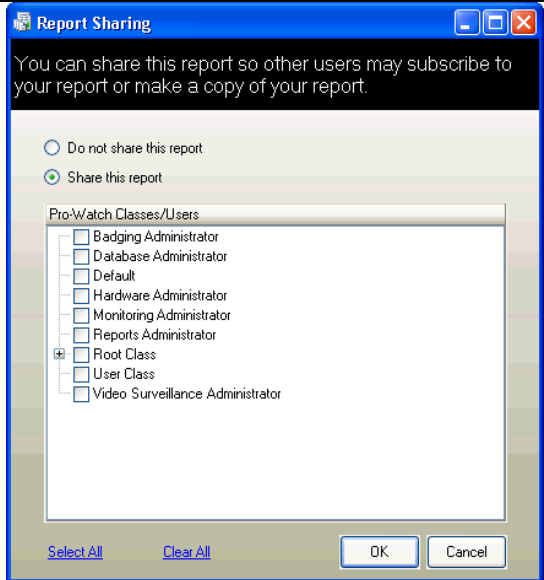

- ### Sharing Reports
- The Compliance Report Manager includes a function to share, or make available, your reports to users in the Pro-Watch environment. To designate a report to be shared:
1. Right-click the specific report you want to share—for example, Badge Holder Access to Logical Device, and select **Share Report** to display the Report Sharing dialog box.
  2. Click the button to share the report.
  3. Select the personnel with whom you want to share the report. You can select a Pro-Watch class of users, or select individual users.
  4. Click **OK**.
- The report is now stored in a repository that may be accessed by you and by the users you have designated to share your reports with.

## 20 - Archiving

Archives are used to remove data from two tables that grow at a fast rate. These are the Event Log and the Audit Log. Since each log is a separate table the archives for these logs have to be made separately. Using the manual method shown here you will need to create a separate archive for each date that you want to do an archive on.

After running the archives it will be necessary to run a cleanup script that removes the empty lines from the table and reduces the size of the table.



To create an archive click on the Administration icon on the Viewer bar.



Next expand the Archives folder, click on Archives, and then right click the right hand window. Select "New" from the menu.

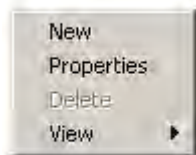

In the Define Archive window, fill in all of the blanks at the top of the window. Remember to use the browse button to find the location for the archive file to reside.

Next the Start and End Dates is the Start and End dates of the data that you want to remove from the database and archive.

The Desired Start Date is when you want the archive to run. It can be any-time in the future.

Select the Archive radio button if all you want to do is to make a copy of the data. Use Archive and Purge to copy the data and then remove it from the working database.



When you click OK the new Archive icon will appear and the archive will run automatically on the date specified.

To run a report on the removed data it must be restored. Open the archive and select the Restore radio button. Use the Append feature if you are going to restore multiple archives and run a report across all of them, or use the Replace feature if you are only going to restore one archive.

When you are ready, click the Apply button.

Be sure to use the Purge feature when you are finished. This will keep the database clear of old data and reduce it's size.

## Lab – 10 Manual Archive

Archives are used to remove data from two tables that grow at a fast rate. These are the Event Log and the Audit Log. Since each log is a separate table the archives for these logs have to be made separately. Using the manual method shown here you will need to create a separate archive for each date that you want to do an archive on. First verify that the table has data in it.

- A. Click the **Reports** icon in the Viewer bar.
- B. Click on the “Query Report” tab.
- C. Enter the following text: `select * from ev_log`
- D. Click the Finish button. The report should have your event data in it.

Now create your archives and run them

1. To create an archive click on the Administration icon on the Viewer bar.
2. Select the Archive item plus sign.
3. Select the Archive item
4. Right click the window
5. Click the New menu item.
6. The **Define Archive** dialog opens
7. Enter a Name for the Archive
8. Enter a description for the Archive.
9. Enter your name in the Operator ID box
10. Click the Media ID **Browse** button
11. Search for a place to put the Archive. In this case put it on the desktop so you can find it later.
12. Select the **File name** text box and name the Archive file.
13. Click the **Open** button
14. Select the **Event Log** radio button





15. Enter the Start Date and Time. Make it a week before class started at midnight.
16. Enter the End Date and time. Make it four hours ago.
17. Select the Archive and Purge radio button.
  
18. Leave the Desired Start Date alone. It should be a few minutes ago.
19. Click the **Apply** button
20. Watch the Archive and Purge run, then Click the **Cancel** button
21. Repeat these steps for another archive but this time archive and purge the Audit Log
21. Click the **Reports** icon in the Viewer bar.
22. Click on the "Query Report" tab and enter the following text:  

```
select * from ev_log
```
23. Click the Finish button. The report should be empty showing that your data  
has been purged.
24. Next enter the following text:  

```
select * from worksp_ev_log
```
25. Click the Finish button. The report should have your restored data in it.

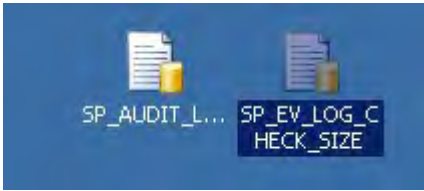
## 21- Auto-Archive

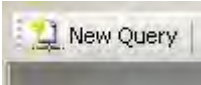
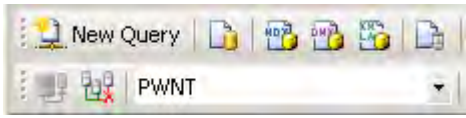
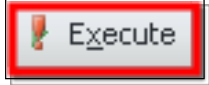
<p>Pro-Watch Automated Archive and Purge, will manage your history and audit log maintenance. You select the number of days to keep “current” in the system, and let Pro-Watch archive and remove all older events.</p> <p>To start the process you have to run the <i>three</i> SQL scripts. These are included with the Automatic Archive and Purge zip file. After the scripts are run, you will need to setup one archive for the Event Log, and one for the Audit Log. These only need to be setup once. Once they are setup, they will reference the settings you make, in the Pro-Watch Event manager to setup how much data to keep on your server.</p>	
<p>In this tutorial we will run both scripts, and then setup the details for the Event Log. We will then repeat the setup of the details for the Audit log.</p> <p>Unzip the file. Chose a location of your choice. Run both SQL scripts.</p>	
	<p>Double click one of the unzipped .sql files. This will open the SQL Query Analyzer connect dialog box.</p>
	<p>Connect to the SQL Query Analyzer. If the connect box doesn't open click the “New Query” button at the upper left corner of the window.</p>  <p>This will open the connect window. Connect to the SQL Query Analyzer.</p>
<p>Drag the file into the Query Analyzer screen. This will populate the screen with the script. You can also copy the file and paste it into the query analyzer.</p>	
	<p>Change the database name at the top of the screen to PWNT.</p>
	<p>Click the Execute Button, it has a red exclamation mark (!), to execute the script.</p>

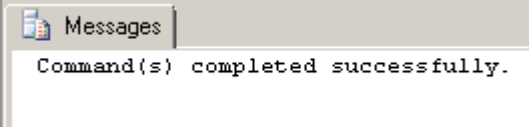
	<p>The message that it was completed successfully will display at the bottom of the screen.</p> <p>Repeat the process for the other script.</p>
---	---

	<p>Now setup the archives in Pro-Watch. Click the Administration icon.</p>
---	--

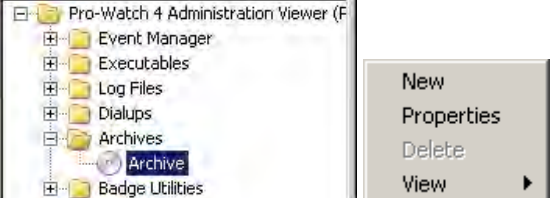
	<p>Expand the tree, expand Archives, and select Archives. After you have selected Archives in the tree, right click the right hand window and select "New" from the menu.</p>
---	---

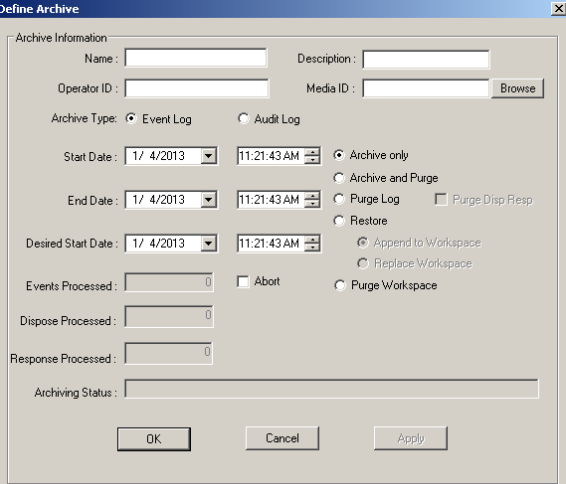
	<p>This will open the "Define Archive" dialog box.</p>
--	--

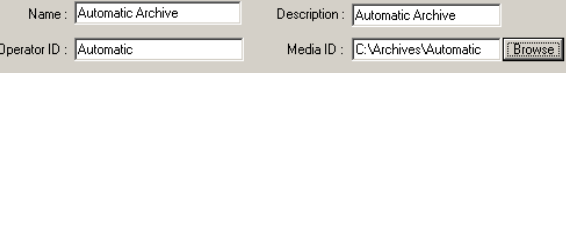
	<p>The Name and Description will be "Automatic Archive". The Operator ID and Media ID will both be "Automatic". DO NOT use any other names for these entries and be sure to use the browse button when adding the Media ID.</p>
---	---

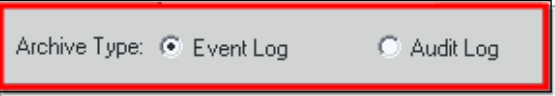
	<p>By default, the radio button for Event Log is already selected. When you make the Audit Log archive, you will have to change the radio button, and select Audit log.</p>
---	---

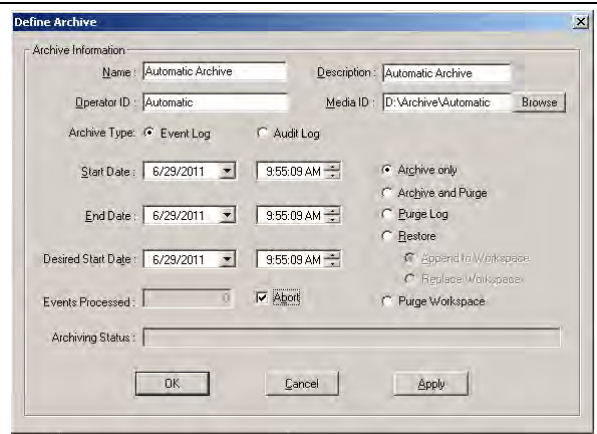
	<p>The last thing to do is to select the "Abort" check box.</p>
	<p>Once you have made these changes you are finished with building the Archives.  <b>DO NOT</b> make any other selections in the Define Archive dialog box.           Click the OK button.</p>
<p>When the archives run SQL will automatically add the prefix of EVARC or ALARC and include the start and end date.          Example : "EVARC01_01_2009 to 01_31_2009.AR"           Now setup the amount of data to keep in the database.</p>	

The next step is to open the Pro-Watch event manager, and set the limits for the amount of data to keep on the server. Once you do that, the automatic archive feature will start checking the database. The archiving works as follows: When you set an amount of history you want to keep active, say 2 months, Pro-Watch will automatically review the data. When the events are 30 days beyond the user defined number of days, (in this case 2 months), Pro-Watch will create an archive file and remove the oldest data, leaving the last 2 months in the active database. Restore information is automatically generated in the software, and an icon will be added to the Archive database for the archive that was created.

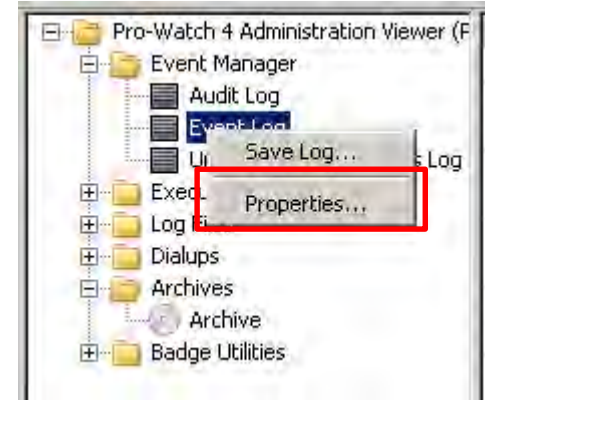
	<p>Expand the Event Manager and right click the Event Log.           From the menu select the Properties... menu item.</p>
---	--

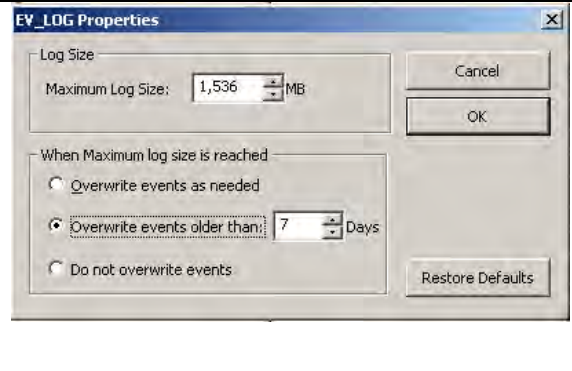
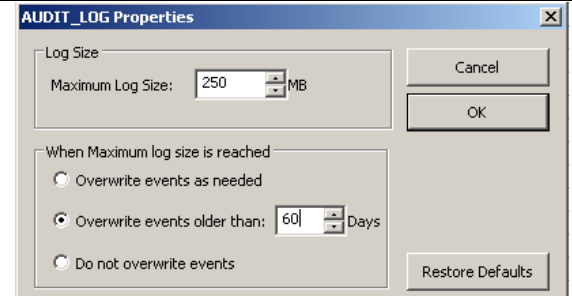
	<p>When the properties window opens, Select the <b>Overwrite events older than</b> radio button. This is where you define the amount of data to keep on your server in the active database. After you have set the number of days of data to keep, click the OK button.</p>
	<p>Repeat the process for the Audit Log.</p>

## Lab - 11 Auto-Archiving

Follow the previous steps to create an Event Log Automatic Archive, and an Audit Log Automatic Archive.



## 22 – Backup and Restore

### Backups

Select the Pro-Watch Enterprise Manager menu item

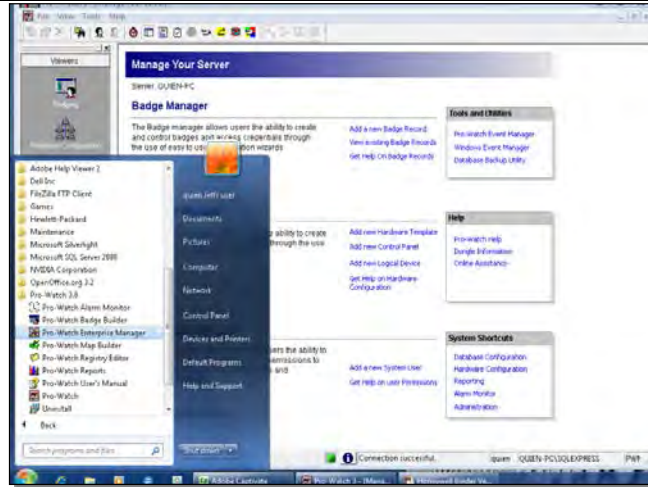

Expand the menu and select the Backup Database item. By default the Complete Backup radio button will be selected. Enter a description for your backup. Decide if the backup will be a complete or a differential.

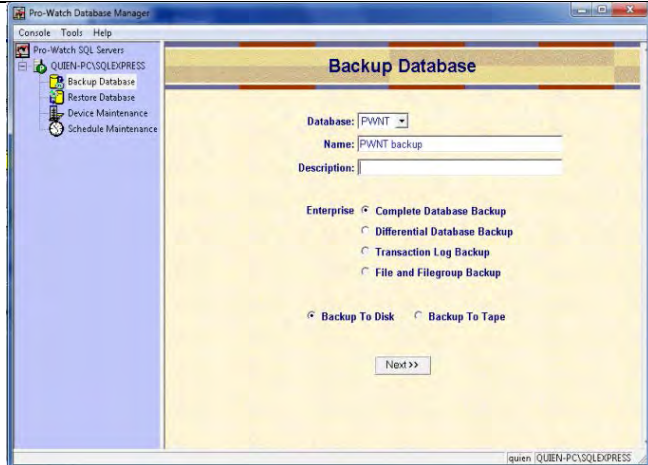

Click the Next button.



Use the ellipses browse button to locate the place you want to store the backup and then give the backup a name. Use the file extension of .bak. You also want to decide if this backup is going to be appended, or added to the previous backup, or whether it will replace the previous backup.





If you click the Backup Database Now button, it will immediately start backing up the database. The other option would be to schedule the backup to run repeatedly at a certain day or date, and time.



Another thing to do would be to schedule the backup to take place automatically. Click the **Schedule >>** button



The Add Scheduled Backup window will open.

Use the radio buttons to setup a recurring schedule of backups.

When you are finished click the "Save Scheduled Backup" button.

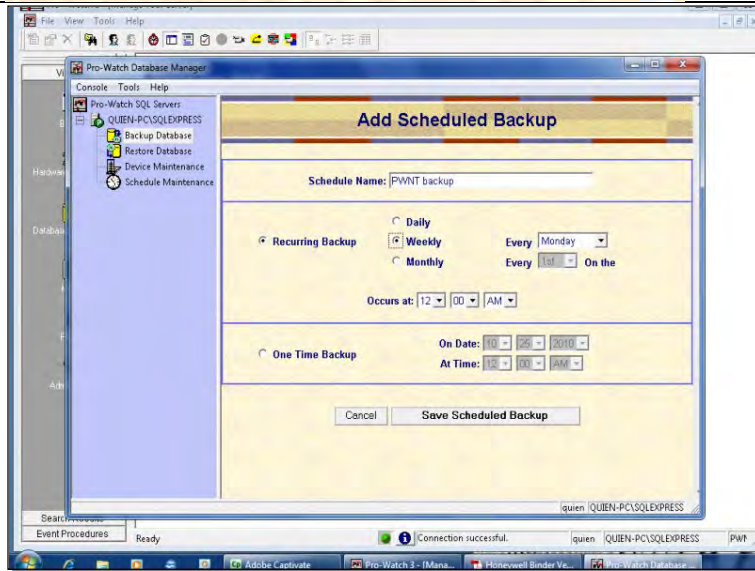

Click the Scheduled Maintenance menu item.

All of your scheduled maintenance should be listed here. From here you can edit the schedule, enable or disable the backup, or actually delete the scheduled backup.

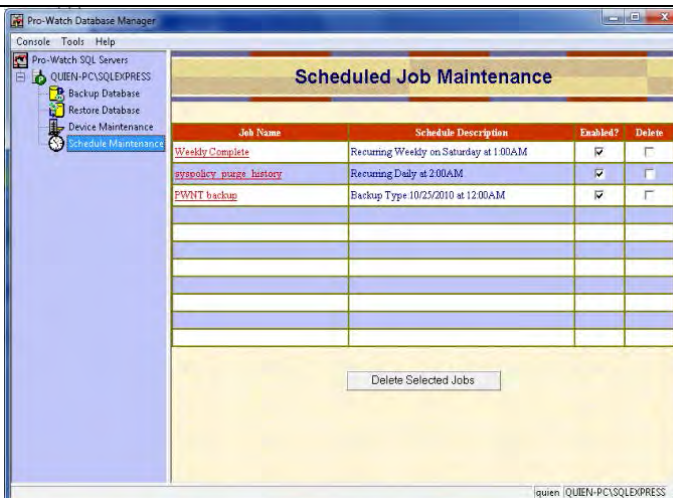

Restore

To restore a backup the first thing that must be done is to stop the Pro-Watch service.

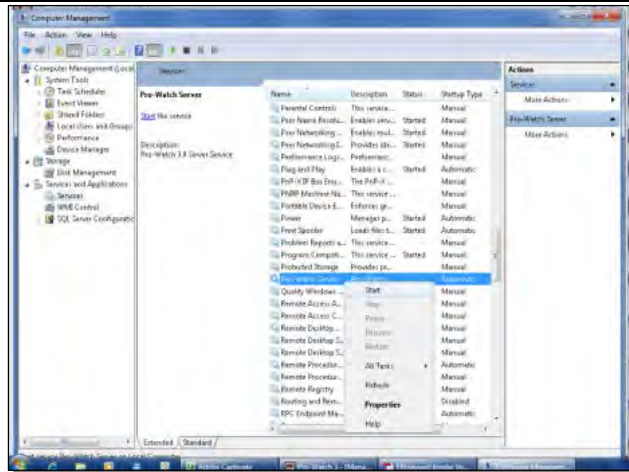

Next, return to the Pro-Watch Enterprise manager and select the Restore Database menu item. The "Restore as Database" radio button is set to Existing. This will replace the current database with the backup. Leave the "Restore From" radio button set to Device, and click the Next button.

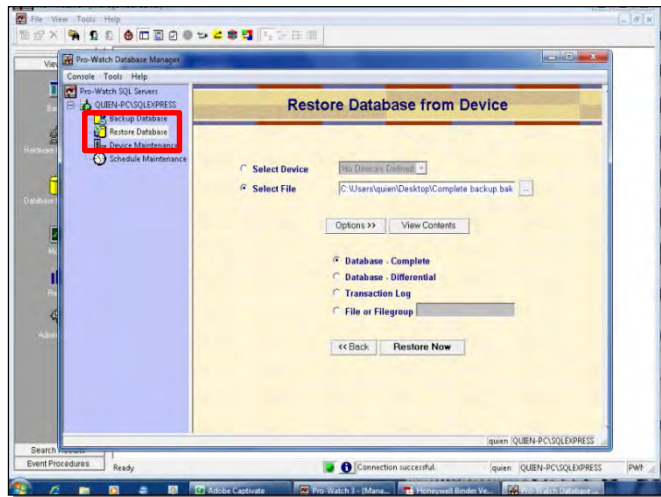

Use the Browse button to find the backup you will restore. Click the Restore Now button.

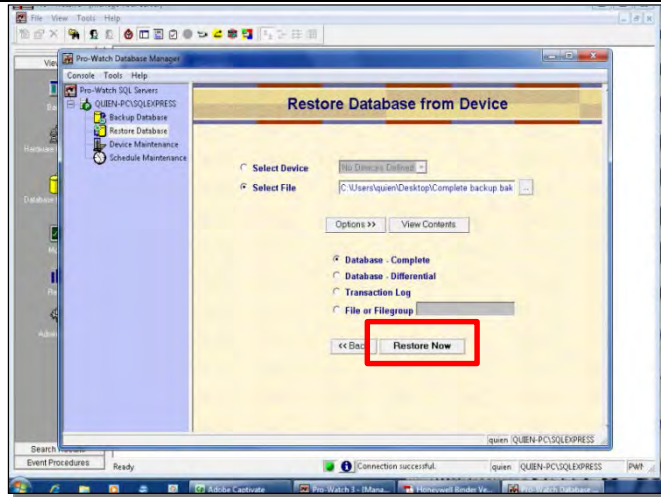

The Backup will restore. When it is finished remember to restart the Pro-Watch Server service.

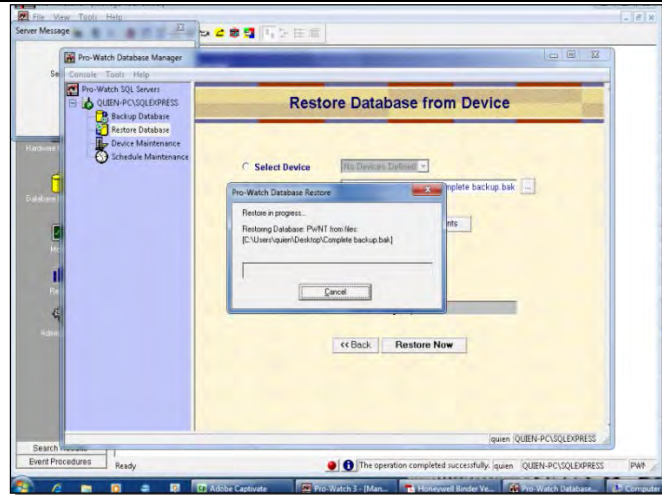
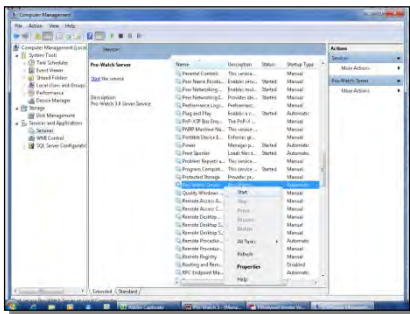

## LAB - 12 Backup and Restore

### Backup the Database

1. Click the Start button
2. Select the **Programs** menu item
3. Select the **Pro-Watch 4.0** item
4. Select the Pro-Watch Enterprise Manager menu item
5. Expand the Plus sign
6. Select the Backup Database item
7. Select the Description text box and enter "Weekly Complete".
8. Click the **Next >>** button
9. Select the File radio button
10. Use the ellipsis box and browse for a location to place the backup. In this case place it on the desktop.
11. Name the file Class Week Complete.bak
12. Select the Overwrite Existing Media radio button
13. Click the Backup Database Now button
14. Click the **OK** button
15. Repeat the process except don't use the Backup Database Now button use the Schedule button.
16. Click the **Schedule >>** button
17. Select the Weekly radio button
18. In the Every box select today.
19. In the occurs at: box select 5 minutes from now.
20. Click the Save Scheduled Backup button
21. Select the Scheduled Maintenance item
22. Your scheduled backup should be there.
23. Click the **Close** button

### Restore the Database

24. Stop the Pro-Watch service.
25. Open the Pro-Watch Enterprise Manager
26. Select the File/Filegroup radio button
27. Place a check in the box that is in the Restore column, next to your first backup.
28. Click the Restore Now button.
29. Let the restore finish.
30. Click the **Close** button
31. Restart the Pro-Watch service.
32. Open Pro-Watch.
33. Check to see if there is any hardware built. It should be empty.
34. Repeat the process and restore your Class Week Complete backup and you should find all of your programming.
33. End of Lab.

## **Appendix**

### **PW6000 series panel Hardware**



Ports 3–6 are RS-485 interfaces. These interfaces allow multi-drop communication up to 4,000 feet (1,250 m total per port). Use two twisted pairs (120Ω, 23pF minimum 24 AWG) with shield for the communication. Install termination jumper only for end of line unit. The default speed of each these ports is 38.4Kbps but they can be downgraded to 19.2Kbps or 9.6Kbps if the line conditions or receiving equipment require it (see jumper and DIP switch settings). Up to 32 boards can be connected in any combination to ports 3, 4, 5 and 6.

**For Wiring to an RS-485 port:**

1. TR+ is the plus side of the transmit and receive differential signal.
2. TR– is the negative side of the transmit and receive differential signal.
3. GND is the signal ground. The wiring for this signal is required and **NOT** optional. This signal must **NOT** be tied to Chassis Gnd.
4. Use 24 AWG low capacitance, two twisted-pair, shielded cable (Belden 9842 or equiv.).

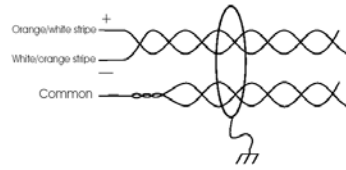

*Note: For N-485 Communication Connections, twist the blue pair together and use as the common; use the orange pair as your data pair, observing polarity. Connect the external drain shield to the appropriate earth ground on one end.*

5. When daisy-chaining RS-485 ports together connect the TR+ wires from the upstream and downstream boards to the TR+ terminal and likewise, connect the TR– wires from the upstream and downstream boards to the TR– terminal.

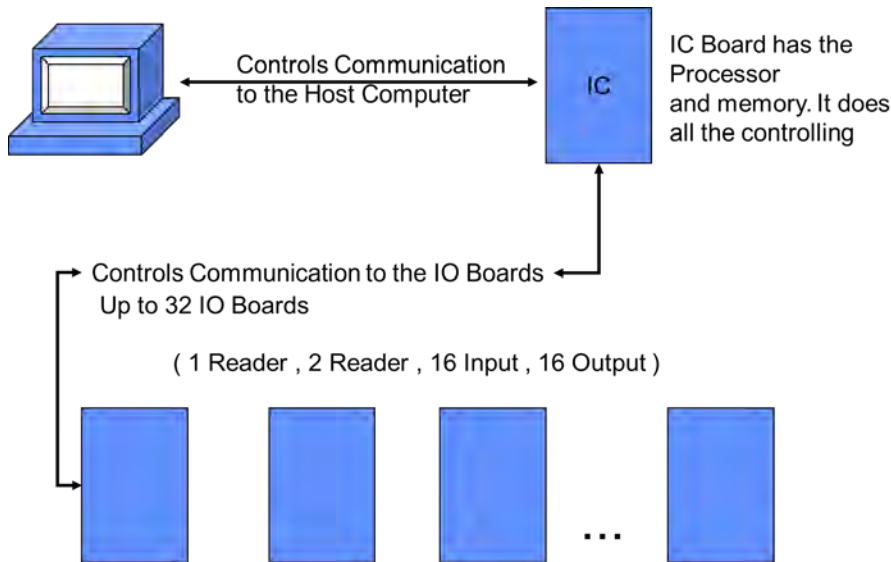

The IC board has 2 communication paths, each with their own addressing scheme. The Host path has addresses 0-7, and the IO board path has addresses 0-31.



Part Number: PW6K1IC

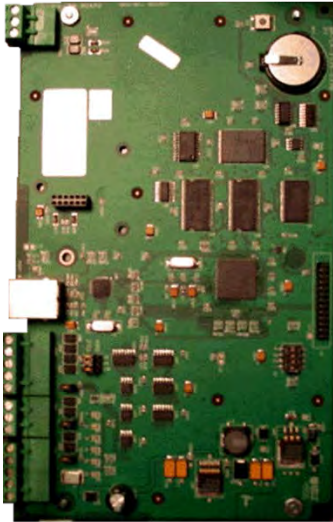

The PW6000 is a replacement board for the PW5000 IC. To program the PW6000 in Pro-Watch you will use the PW5000 selections. It programs the same. Some of the differences are:

1. Built in TCP/IP interface.
2. Settings are made via a web interface instead of with EZWEBCON and DIP switches.
3. Downloads are twice as Fast.
4. Supports up to 300,000 cards

Tamper and Power Fail



Optional Ethernet Connection for Redundant TCP/IP



Built in Ethernet Connection Used in place of Port 1.



Port 1 – Primary Host Comm.



Ports 2 & 3 – RS485 ports for IO Boards. 4000ft each.

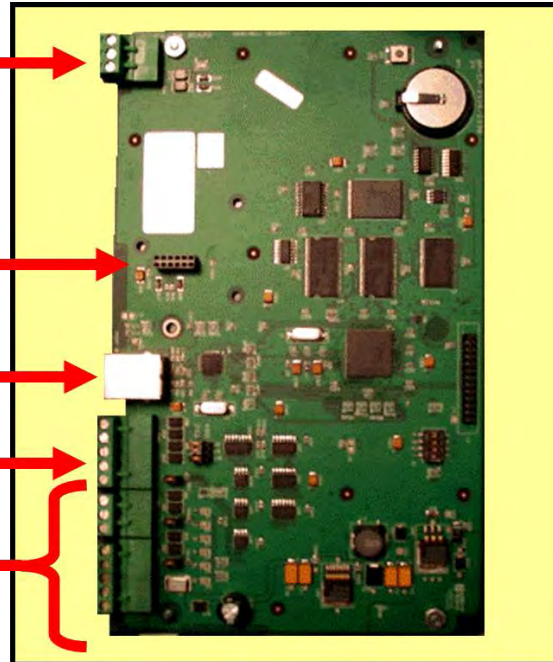
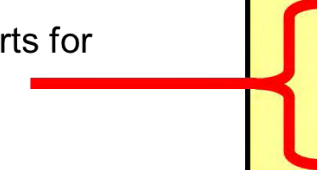

# PW6000 Initial Setup Step 1

## System Configuration via Web Interface

PW-6000 comes with **Access Control Device Server Manager (ACDSM)**, i.e., a built-in web server through which the users can configure their network and other system settings.



**Note:** The default factory-set TCP/IP address for the built-in system configuration web server is **192.168.0.251**

### A) Connecting to ACDSM for the First Time

1. Use the factory default controller IP address **192.168.0.251**.
2. Set the DIP switches to **S4=OFF, S3=OFF, S2=ON, S1=ON**.
3. Connect the computer to host the web server via **Ethernet Port 0**. Connection should be via crossover Ethernet cable or by the regular Ethernet cables connected via the hub.
4. Set the host computer to the static IP address **192.168.0.250** to be able to connect to the factory-default PW-6000 controller at address **192.168.0.251**.
5. Power up the PW-6000 controller.

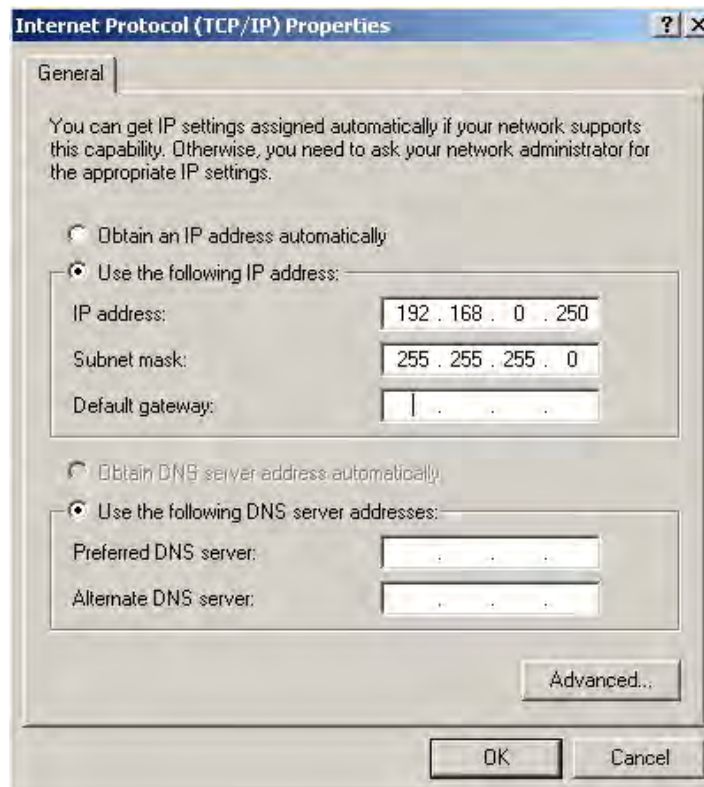

Open Internet Explorer and type in the address of 192.168.0.251 in the address bar. Click the Enter key.

**IF you cannot connect to the IC board the default the IC board. See page 110.**

Address http://192.168.0.251/ Go Links Free Hotmail

# Honeywell

[Click Here to Login](#)

↓

Access Control Device - Login - Microsoft Internet Explorer

File Edit View Favorites Tools Help

Back Search Favorites

Address https://192.168.0.251/login.htm Go Links Free Hotmail

## Access Control Device Server Manager

### Login

Enter your user name and password.

Username:

Password:

Enter the User ID of "admin" and the password of "password". Click Login

Navigate to the "Network" menu selection. Set the Static Network IP Address, Subnet Mask, and Router address from this page. When finished click the "OK" button.

The screenshot shows a Microsoft Internet Explorer browser window displaying the configuration page for the Honeywell PW6000 Access Control Device Server. The browser's address bar shows the URL: `https://192.168.0.251/~user_handler?file=logged_in.shtm&session_id=2683`. The page title is "PW6000 - Access Control Device Server Configuration Manager". On the left side, there is a navigation menu with the following items: Home, Network, Host Port, Device Info, Users, Restore/Default, Apply Setting, and Log Out. The "Network" item is highlighted with a blue background, and a red arrow points to it from the left. The main content area is titled "Network Settings: IP Configuration". It contains two radio button options: "Using DHCP Method to Obtain IP address automatically" (which is unselected) and "Use Static IP configuration:" (which is selected). Below these options, there are several input fields: "Host Name of This Device:" with the value "MAC000FE5000000", "IP Address:" with the value "192.168.0.114", "Subnet Mask:" with the value "255.255.255.0", and "Default Gateway:" with the value "192.168.0.1". At the bottom center of the configuration area, there is an "OK" button.



Now go the “Host Port” menu selection.

It is possible to set the IC physical address using the “PW6000 Communications Address” drop down at the top of the page. The default is 0 and Pro-Watch assumes 0 so it is not necessary to change the physical address unless you are daisy chaining 2 or more IC boards off the same RS232 comport Set the communications type. Use the IP Server mode for TCP/IP on the Host port. The default Port Number is 3001. Click the “OK” button.

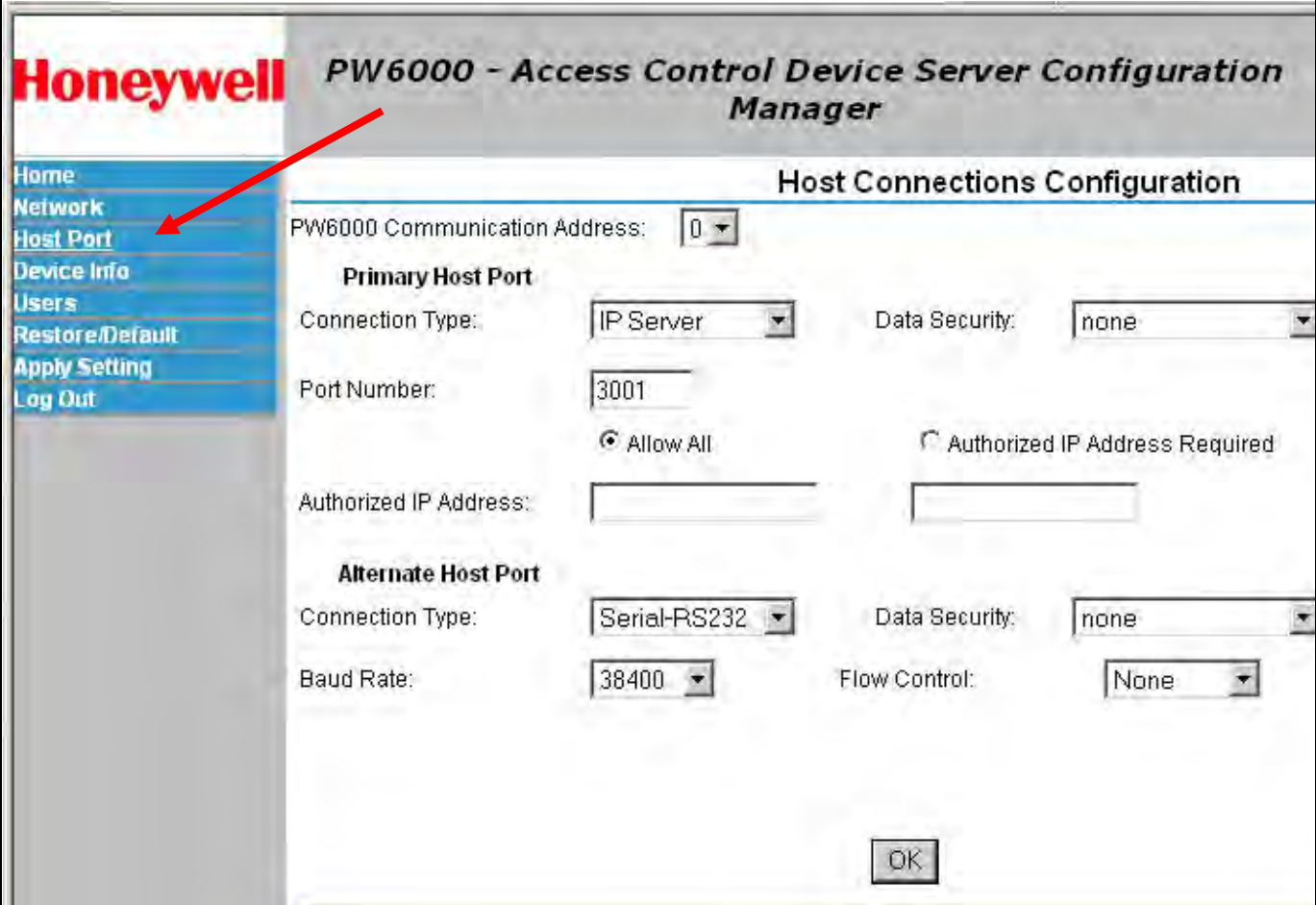

**Honeywell** PW6000 - Access Control Device Server Configuration Manager

Home  
Network  
**Host Port**  
Device Info  
Users  
Restore/Default  
Apply Setting  
Log Out

**Host Connections Configuration**

PW6000 Communication Address: 0

**Primary Host Port**

Connection Type: IP Server Data Security: none

Port Number: 3001

Allow All  Authorized IP Address Required

Authorized IP Address: [ ] [ ]

**Alternate Host Port**

Connection Type: Serial-RS232 Data Security: none

Baud Rate: 38400 Flow Control: None

OK

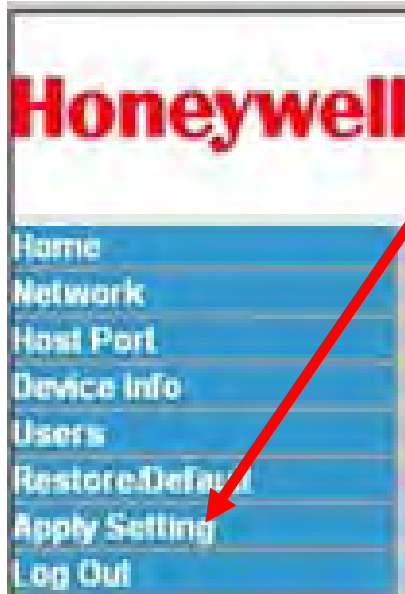

When you have finished programming the panel click the “Apply Settings” menu selection and exit the browser.

WAIT!!!! For the LED’s to quit dancing and go back to the top LED blinking.

At this time set DIP switches 1 and 2 back off and press the reset button.

To default the PW6000 turn DIP switches 1&2 on then hit the reset button. During the first 10 seconds turn DIP switch 1 back off. Watch the LED’s. The LED’s will cycle for about 20 sec and then steady out so that only LED 1 is blinking. The panel will now be reset to factory defaults.



### IO Boards

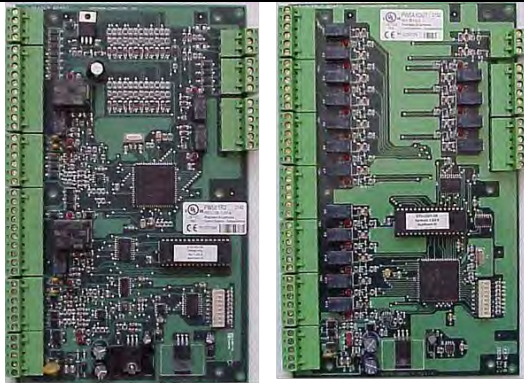

1 Reader Board

The IO boards, sometimes called downstream modules, come in four types. A 1 Reader Board, a 2 Reader Board, a 16 Input Board, and a 16 Output Board. Each IC will support any combination of these up to a total of 32.

**Note:** The Manufacturers manuals use the numbering scheme of 1-32 where as Pro-Watch uses a numbering scheme of 0-31. The location address of each input, output, and reader will be off by one in Pro-Watch. For example, Input 1 as stenciled on the board will be input 0 when it is addressed in Pro-Watch.

### Jumpers and DIP switches

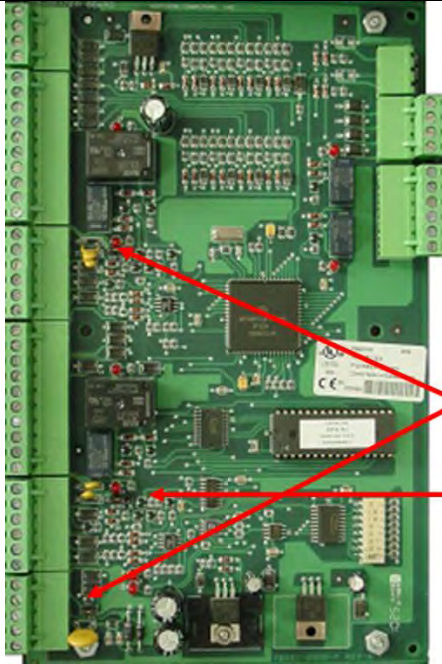

#### Jumpers

J1	OFF	*	Port 1 RS-485 EOL terminator is not active
	ON		Port 1 RS-485 EOL terminator is active
J2	5	*	Reader 1 Power Terminal provides 5 VDC
	12		Reader 1 Power Terminal provides 12 VDC
J3	5	*	Reader 2 Power Terminal provides 5 VDC
	12		Reader 2 Power Terminal provides 12 VDC

Dipswitch Settings:

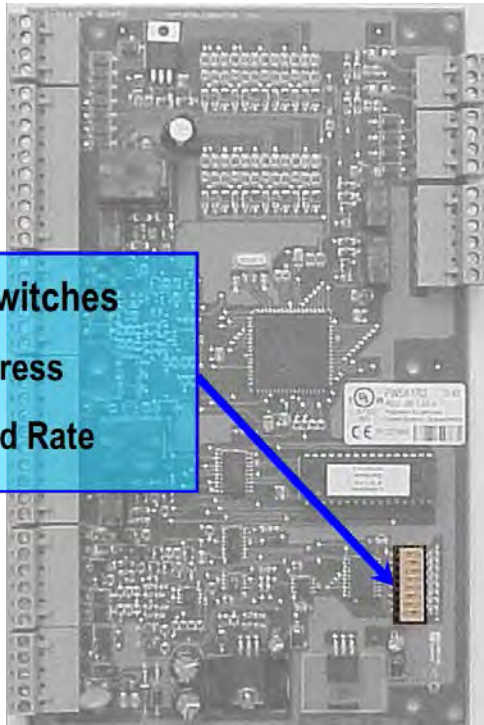

S8	S7	S6	S5	S4	S3	S2	S1	SELECTION
		OFF	OFF	OFF	OFF	OFF	OFF	ADDRESS 32
		OFF	OFF	OFF	OFF	OFF	ON	ADDRESS 1*
		OFF	OFF	OFF	OFF	ON	OFF	ADDRESS 2
		OFF	OFF	OFF	ON	ON	ON	ADDRESS 3
		OFF	OFF	ON	OFF	OFF	OFF	ADDRESS 4
		OFF	OFF	ON	OFF	ON	ON	ADDRESS 6
		OFF	OFF	ON	ON	ON	OFF	ADDRESS 8
		OFF	OFF	ON	ON	ON	ON	ADDRESS 7
		OFF	ON	OFF	OFF	OFF	OFF	ADDRESS 8
		OFF	ON	OFF	OFF	ON	ON	ADDRESS 9
		OFF	ON	OFF	ON	OFF	OFF	ADDRESS 10
		OFF	ON	OFF	ON	ON	ON	ADDRESS 11
		OFF	ON	ON	OFF	OFF	OFF	ADDRESS 12
		OFF	ON	ON	OFF	ON	ON	ADDRESS 13
		OFF	ON	ON	ON	ON	OFF	ADDRESS 14
		OFF	ON	ON	ON	ON	ON	ADDRESS 15
		ON	OFF	OFF	OFF	OFF	OFF	ADDRESS 16
		ON	OFF	OFF	OFF	OFF	ON	ADDRESS 17
		ON	OFF	OFF	ON	OFF	OFF	ADDRESS 18
		ON	OFF	OFF	ON	OFF	ON	ADDRESS 18
		ON	OFF	ON	OFF	OFF	OFF	ADDRESS 20
		ON	OFF	ON	OFF	ON	ON	ADDRESS 21
		ON	OFF	ON	ON	ON	OFF	ADDRESS 22
		ON	OFF	ON	ON	ON	ON	ADDRESS 23
		ON	ON	OFF	OFF	OFF	OFF	ADDRESS 24
		ON	ON	OFF	OFF	ON	ON	ADDRESS 26
		ON	ON	OFF	ON	OFF	OFF	ADDRESS 26
		ON	ON	OFF	ON	ON	ON	ADDRESS 27
		ON	ON	ON	OFF	OFF	OFF	ADDRESS 28
		ON	ON	ON	OFF	ON	ON	ADDRESS 29
		ON	ON	ON	ON	OFF	OFF	ADDRESS 30
		ON	ON	ON	ON	ON	ON	ADDRESS 31
OFF	OFF							Reserved
OFF	ON							9,600 BPS
ON	OFF							19,200 BPS
ON	ON							38,400 BPS*
OFF								Not Used*

\* = Default

The DIP switches are used to set the address of the card and the BAUD rate of the RS485 port. All of the IO boards use the same DIP switch setting.



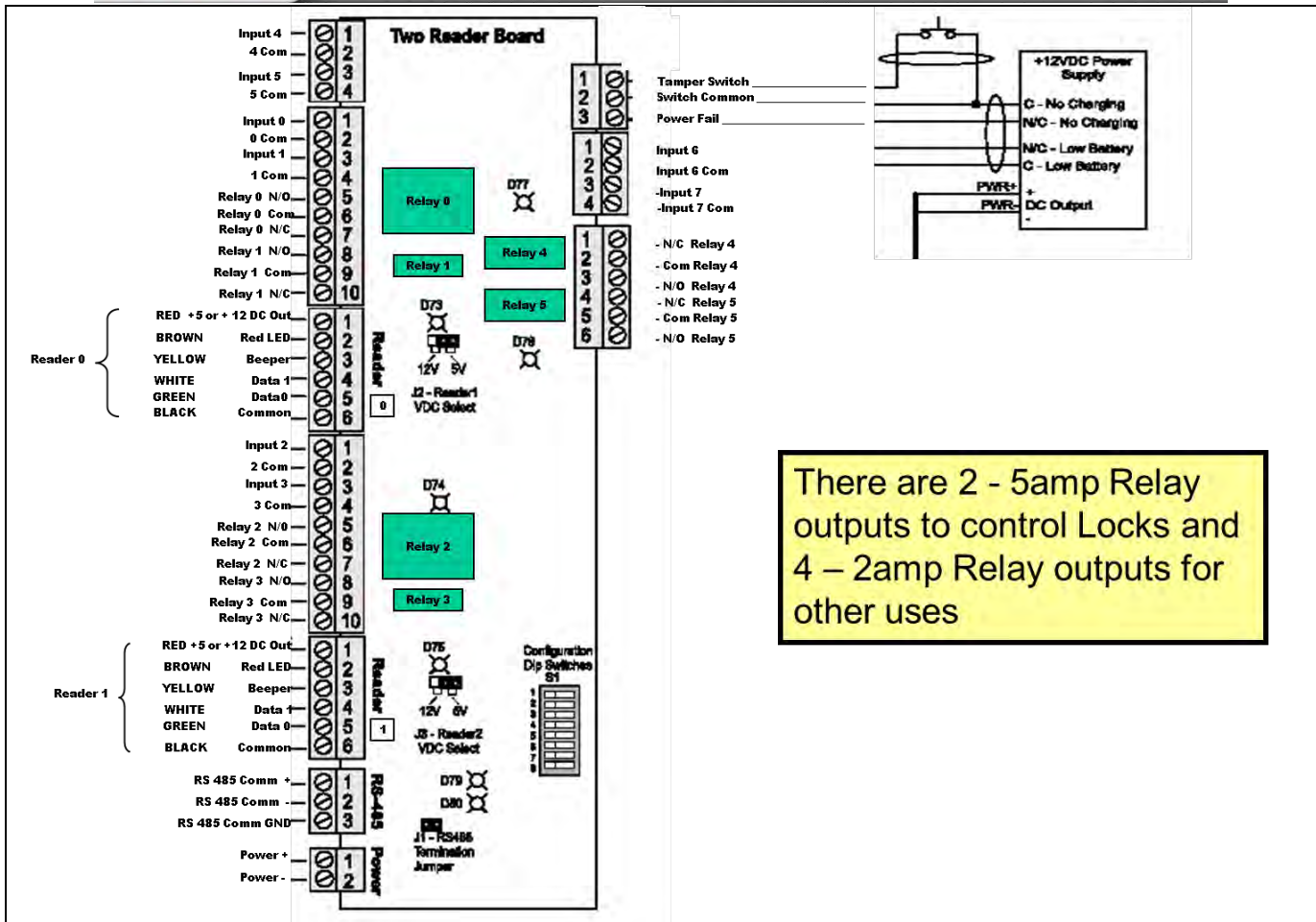

There are 2 - 5amp Relay outputs to control Locks and 4 - 2amp Relay outputs for other uses

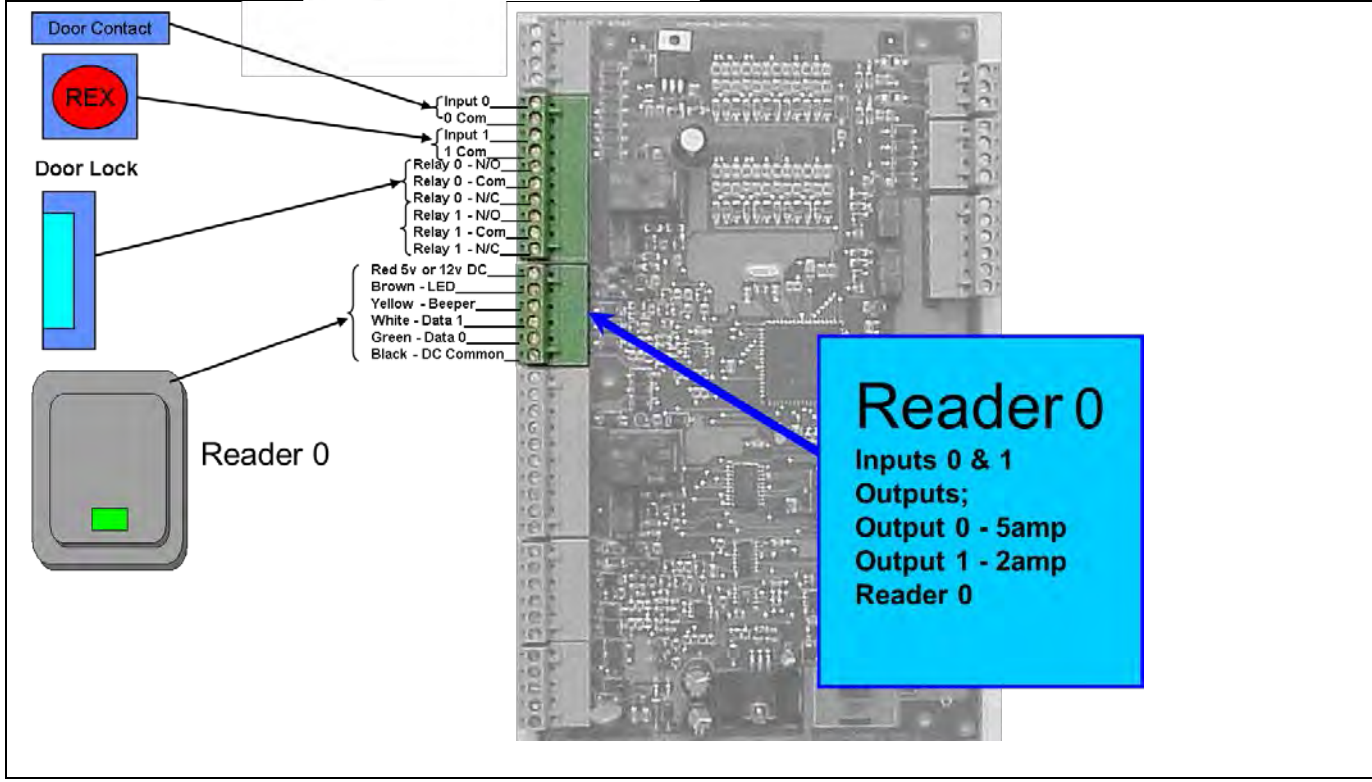

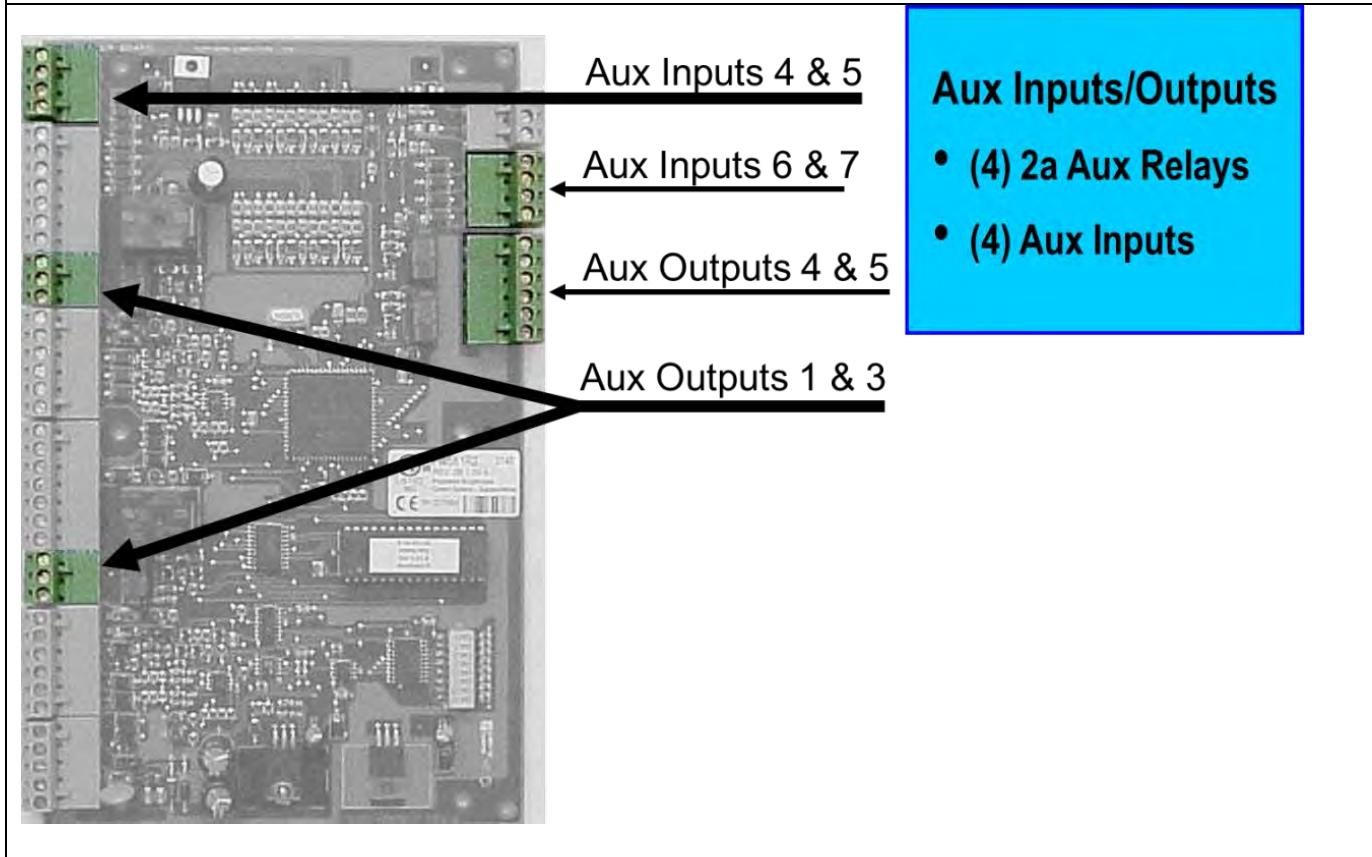
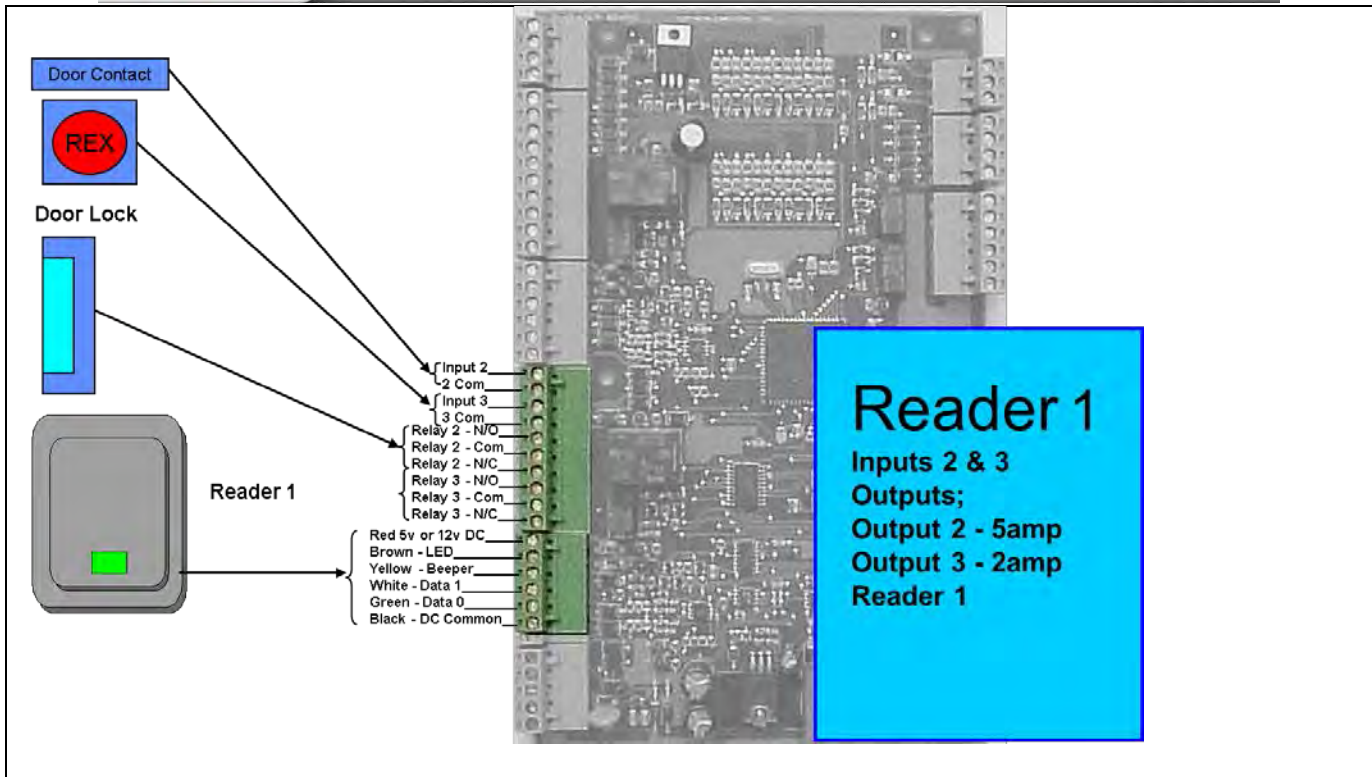



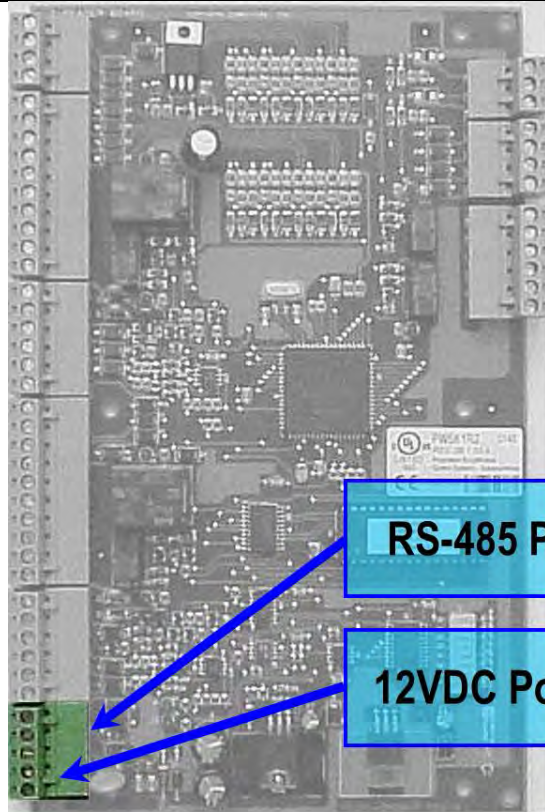

The IO boards all communicate to the IC by way of the RS485 communications bus. The connections are at the bottom of the board because the RS485/Power connector on the IC board is also located at the bottom of the board. When the IC and IO boards are rack mounted in a cabinet then all of the RS485/Power connectors are aligned and a single cable (Daisy Chain) across the bottom of the cabinet connects them.

Note: The IC has 4 RS485 connectors and the RS485/Power connector is Port 6.

## 16 Input board



The 16 Input Module has 16 programmable inputs. They can be selected as Open, Closed, or Supervised. If they are supervised they can use the default of 1000 ohms resistance or you can create custom resistance values. Each of the 16 points can be programmed differently if desired.

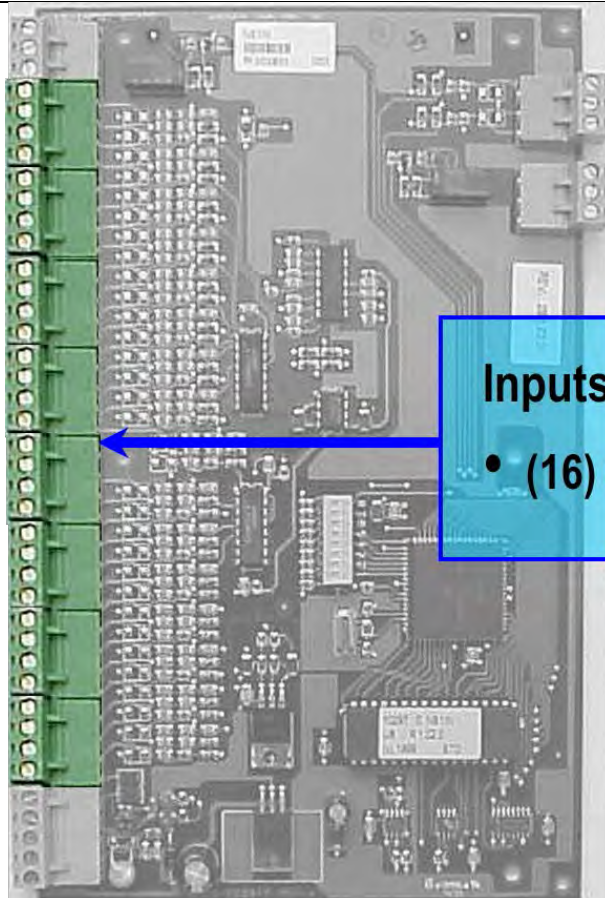

### Inputs

- (16) General Purpose



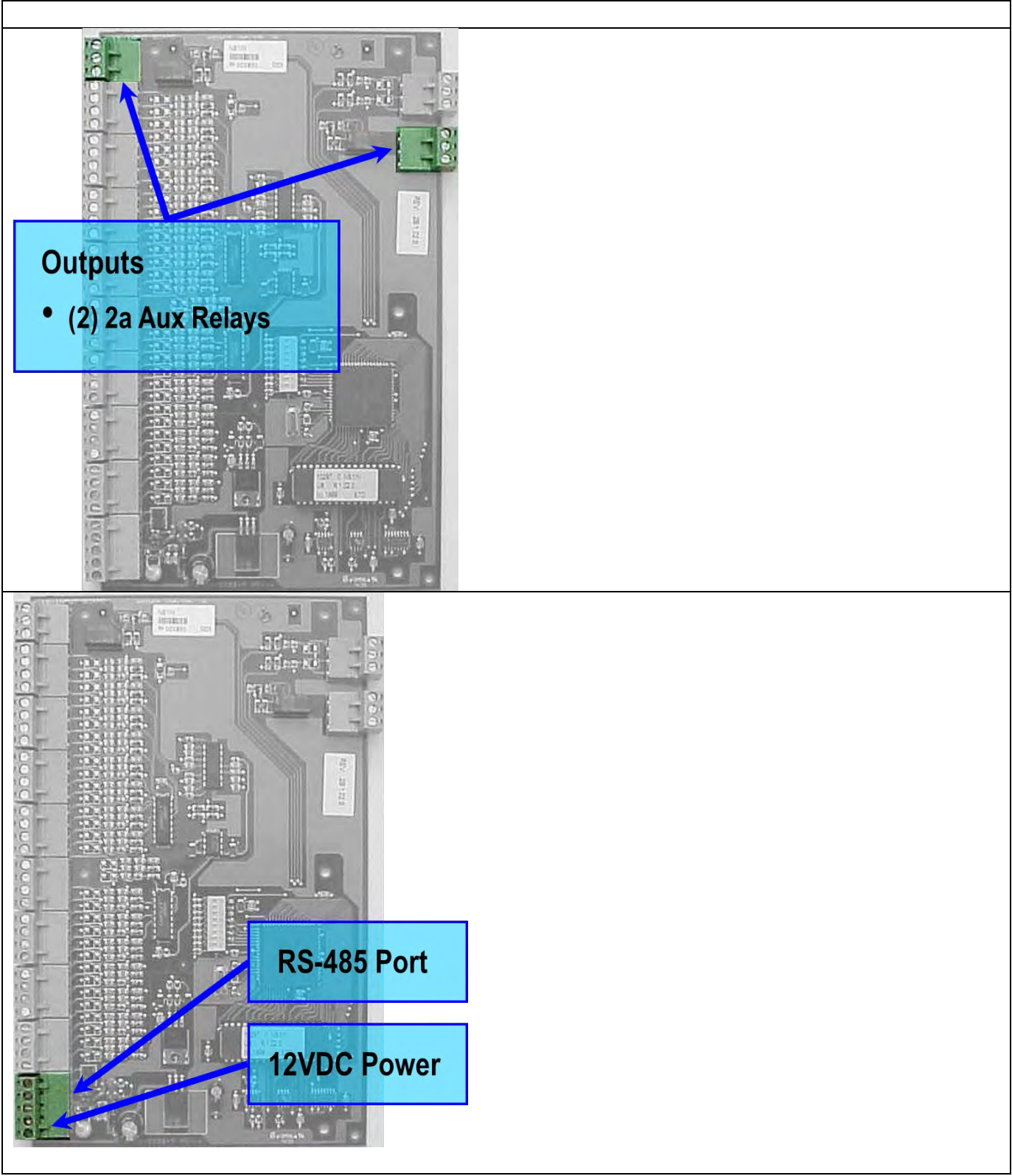

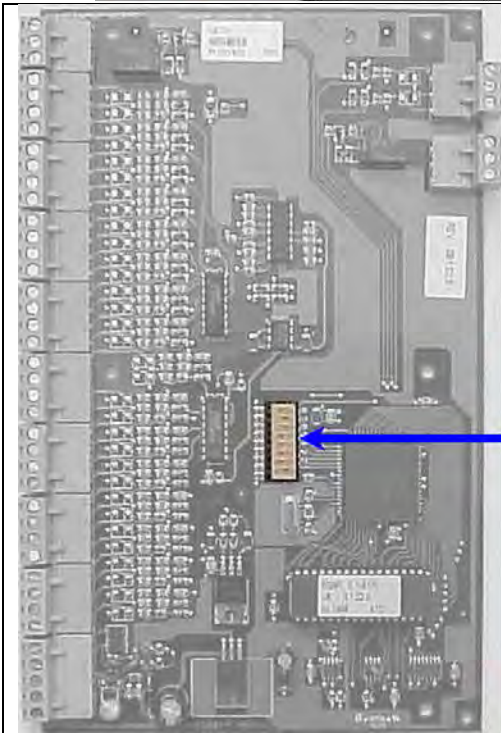

**Dip Switches**

- Address
- Baud Rate
- Same as 2 Reader

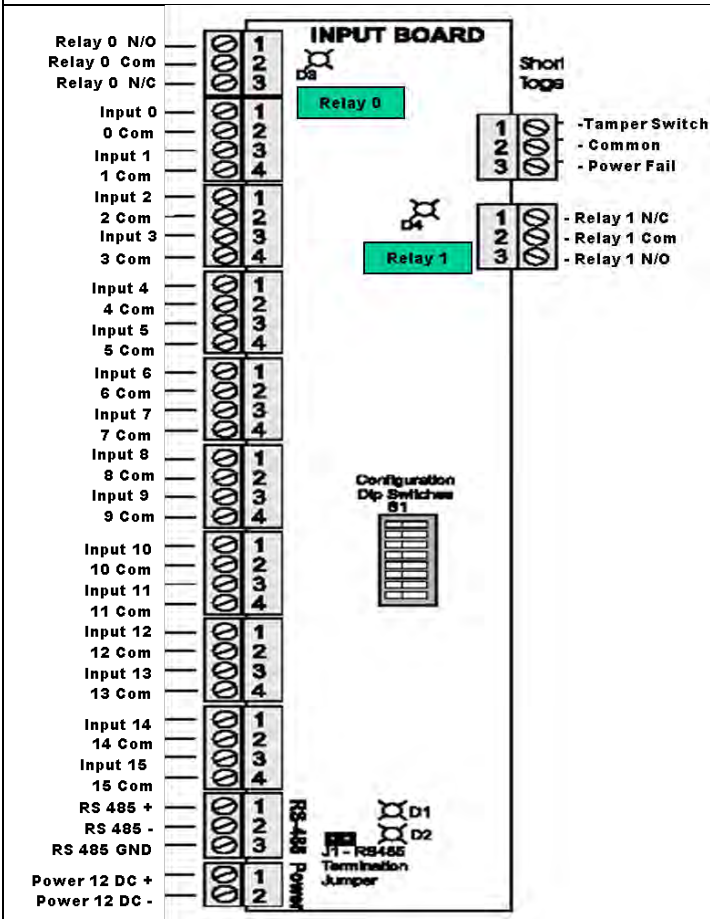

### 16 Output Board

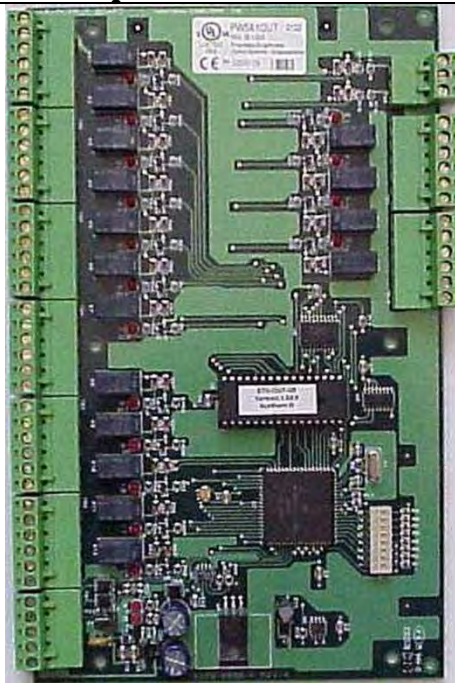

The 16 Relay Output Board has 16 2 amp relays. They each have Common, Normally Open, and Normally Closed contacts.

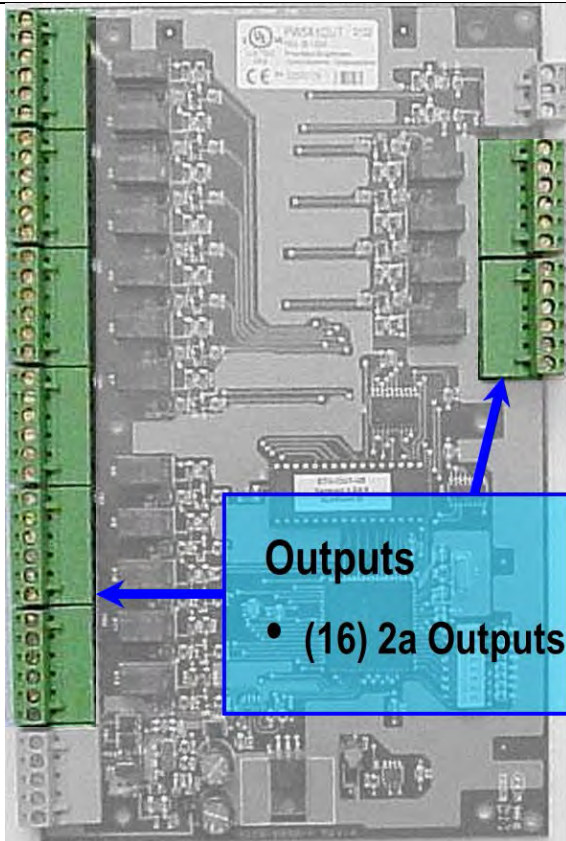



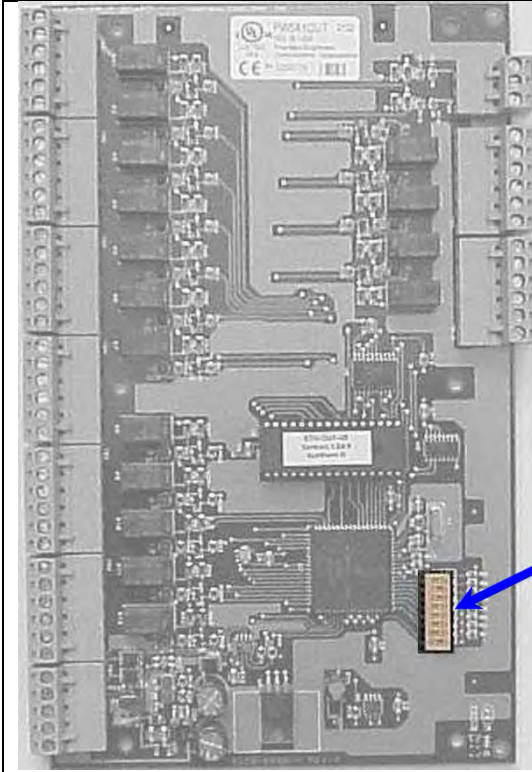

**Dip Switches**

- Address
- Baud Rate
- Same as 2 Reader

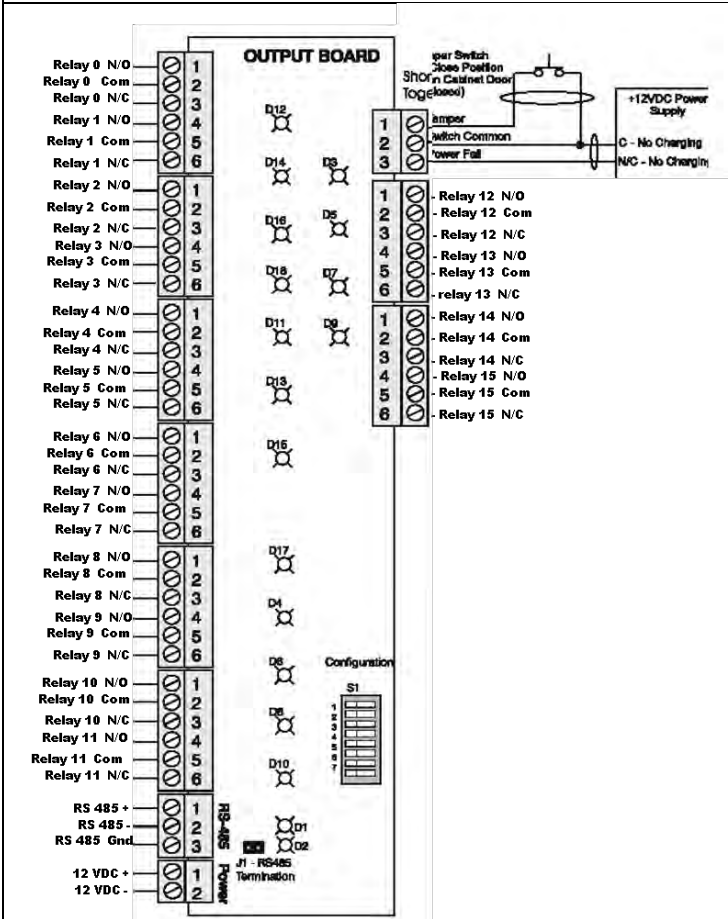

Enclosers

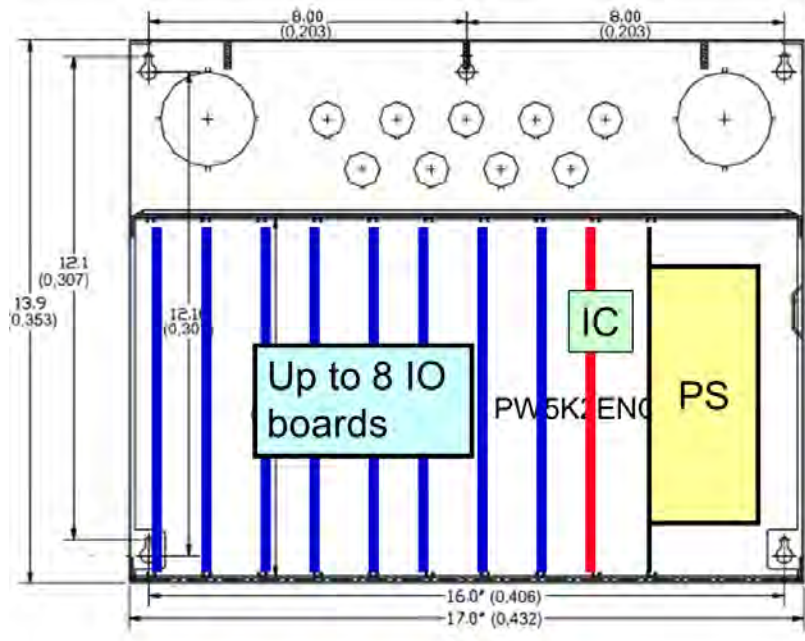

Power Supply  
 IC Board  
 Up to 8 IO  
 Boards

Power Supply  
 Battery

Two Boards of any style:  
 IC or IO

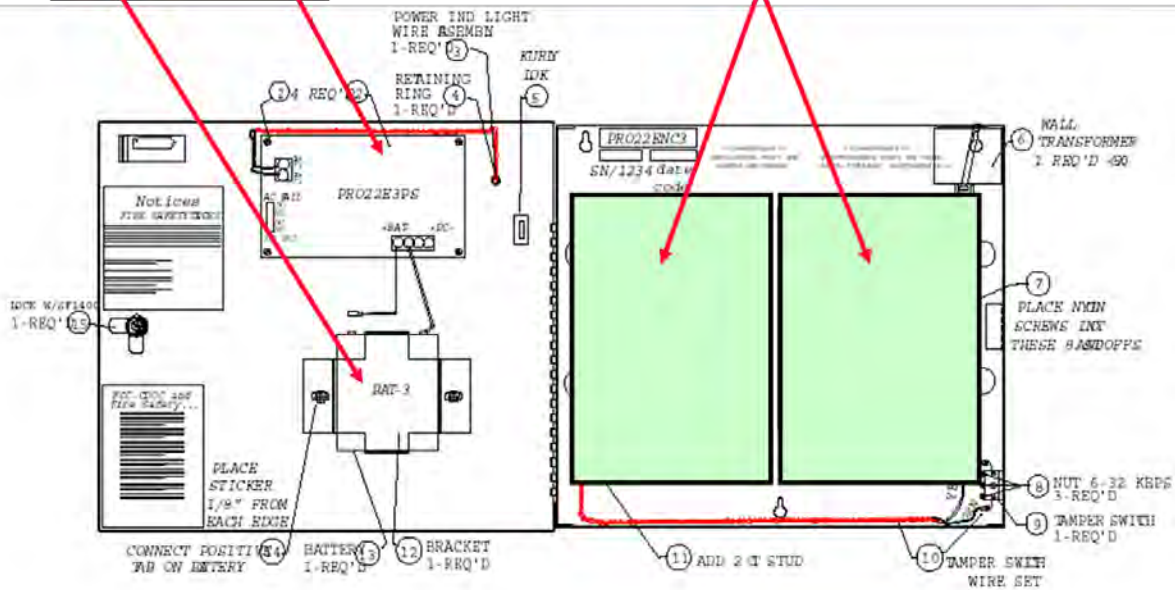



PW5K1ENC4

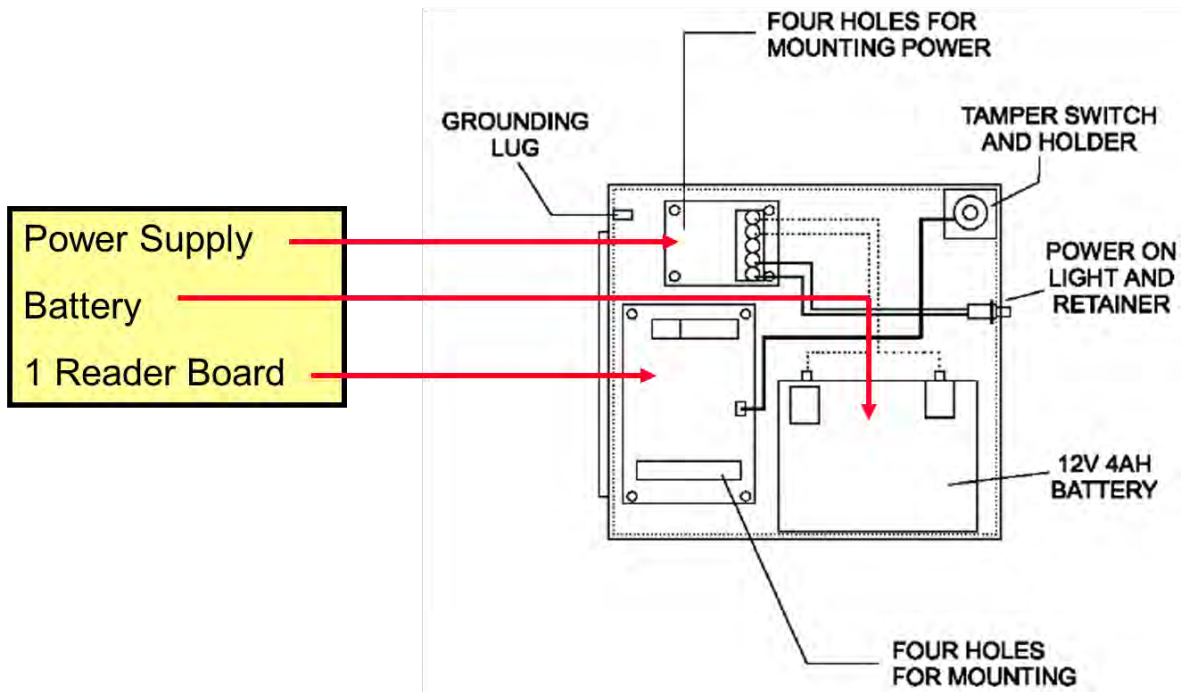

Wiring

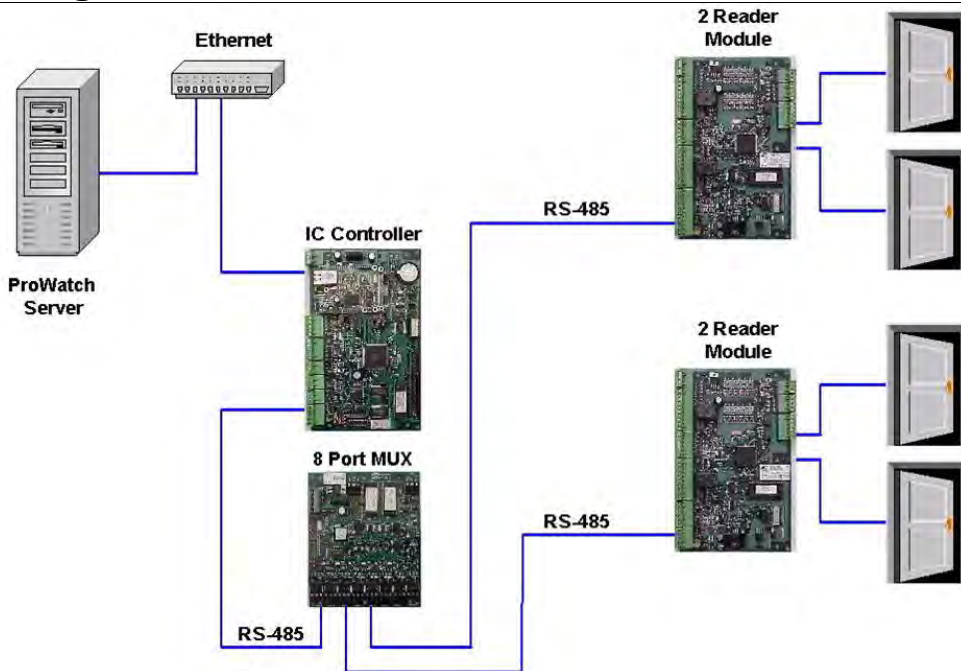

The multiplexer has one RS485 input and 8 RS485 outputs. Each one can be up to 4000ft long. It converts daisy chain the Star.

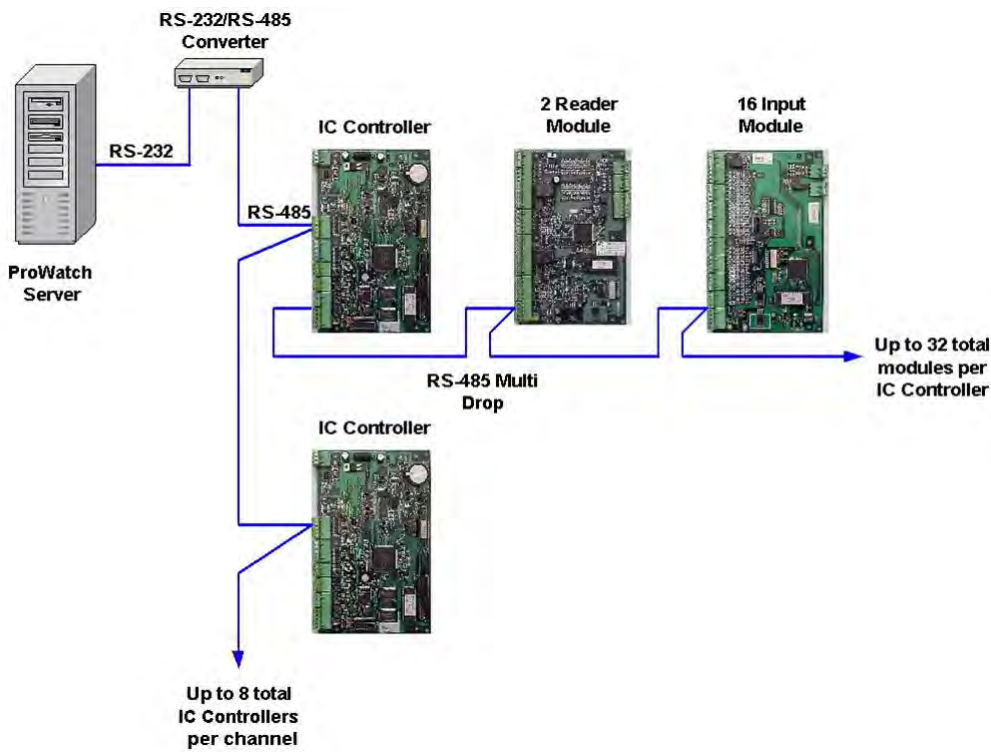

Daisy chaining up to 8 IC boards off of one RS232 com port. Each IC supports up to 32 IO boards.

