

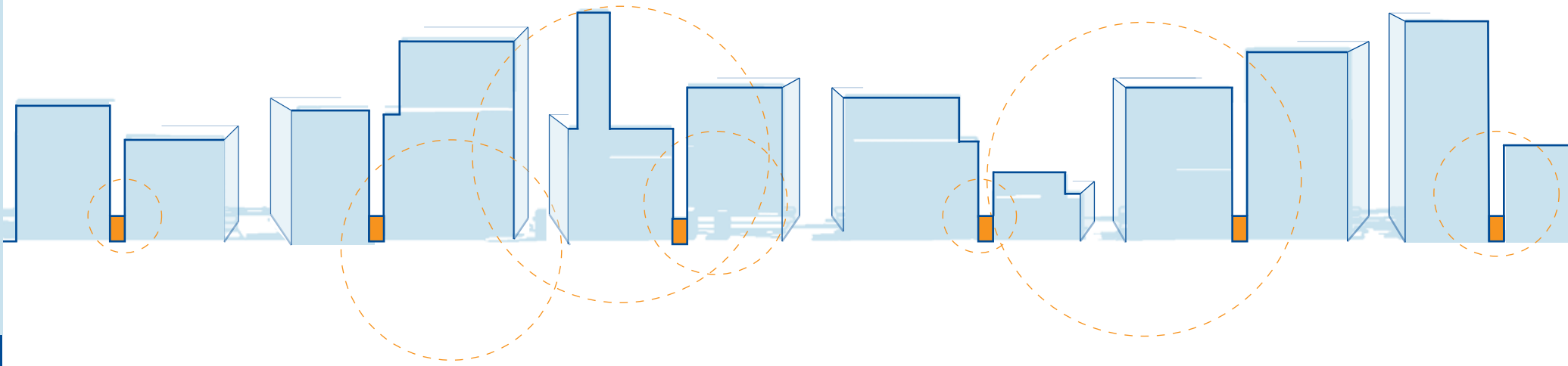

Seattle Integrated Alley Handbook
Activating Alleys for a Lively City

MARY FIALKO AND JENNIFER HAMPTON / IN COLLABORATION WITH:
UW GREEN FUTURES LAB
SCAN DESIGN FOUNDATION
GEHL ARCHITECTS



- Alleys can contribute around 50% of additional public space to the city creating a new network for pedestrians.

Foreword

Alleys are places of drama—enticing in their narrow linearity, exciting in their perceived risk, and scaled as stage sets, where the human body figures large against a constrained backdrop and directed lighting. Alleys are also quintessentially about movement, whether by individuals perambulating and pedaling, vehicles accessing business backdoors, or water flowing from rooftops to drains. With this excitement, potential for human encounter, and utility in moving people, merchandise and water through the urban fabric, alleys possess compelling potential to produce a vibrant secondary public realm that might also help to repair the ecological performance of our cities. Many cities in the world have discovered this capability of alleys to stimulate public life, interpersonal commerce, and enhanced ecological function: Melbourne’s lanes dissect oversized blocks to create networks of people places; Christchurch’s and Auckland’s lanes are loci of vibrant shopping, after-work gathering and nightlife; Tokyo’s narrow shopping and market lanes are filled with 24-hour commerce; and Chicago’s residential alleys bring neighbors together while infiltrating stormwater, keeping it out of overloaded sewers.

Seattle’s alleys possess this same promise, and there is now a surge of interest in reclaiming alley space as a public realm that is useful for more than only service deliveries, with successful local precedents such as Post Alley and Canton Alley to give us confidence. Gehl Architects’ recommendations for using downtown alleys as “green

lungs,” ISI’s Nord Alley celebrations and World-Cup-Watching that engaged over 3000 people this past year, and Seattle Public Utilities’ imminent construction of Ballard stormwater infiltration alleys to reduce sewer overflows exemplify this movement of rediscovering and remodeling our alley networks to greater purpose.

This guidebook is meant to assist individuals and institutions in their efforts to transform Seattle’s alleys, to inspire as well as provide some practical tools. Many thanks go to Jenny and Mary for their passion and conscientious study and to the many people who have given guidance along the way, especially at the City of Seattle and at Gehl Architects. It is my sincere hope that the Integrated Alley Handbook will be well used and that as a result we will see Seattle’s alleys bloom into exciting new public space networks that will also provide green lungs and greater ecological function throughout the city.

Nancy Rottle RLA, ASLA
Green Futures Lab
University of Washington

Why look at alleys?

The stats:

There are approximately **217,500 SF of Alleys**, which are public space, in Seattle's downtown today. **85% of these are underused** and considered to be the 'backside' of the city.

There are 456,390 SF of existing public squares, parks and pedestrian streets in downtown Seattle, according to a 2009 public space study*.

By seriously considering our alleys as potential for great public spaces within the city, **we can increase our public space by 50%** in downtown Seattle alone.

Reevaluating and reformulating our alleys in Seattle is our greatest chance of integrating exciting, green, and healthy public spaces into our existing urban environment. By using existing spaces, we can change the experience of the city without losing spaces needed for buildings.

* Study done by Gehl Architects

Seattle could use a greater variety of high quality places to rest and enjoy the city, and better navigation for a more walkable city. A clear and safe alley system could encourage exploration of the city, and more enjoyable routes, while a finer grain city is more comfortable for pedestrians.



Public Space Alley in Melbourne, Australia



VISION

Page 6 Vision and Goals

Page 8 Background and Potential

ANALYSIS

Page 12 Integrated Alley Examples

Page 14 Why change?

Page 16 What type of alley do you have?

RECOMMENDATIONS

Page 20 Alley Components

Page 24 Alley Types: Seattle Cases

Page 36 Renovation Approaches

NEXT STEPS

Page 42 Network Strategies

Page 44 Day in the alley life

Page 46 Conclusion and Credits

Page 48 Appendix

Vision



Watching the World Cup in Nord Alley in Seattle Summer 2010

Our vision and goals

1. QUALITY OF PUBLIC SPACE

Seattle lacks a variety of public spaces throughout the city. Great public spaces should be within a 5 minute walk of most residents. A diversity of types of space is also important to exciting city experiences, and alleys are the perfect places to stimulate vibrant city life.

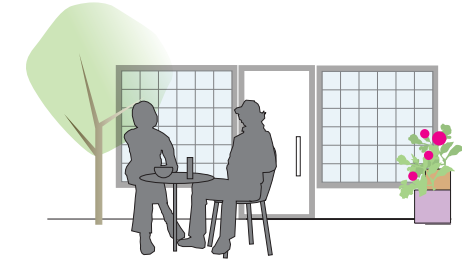

2. HEALTH AND IMAGE OF THE CITY

Although Seattle is making great efforts to become a green city, we still lack a cohesive green network. Alleys are an excellent place for local plants, stormwater drainage, and green infrastructure initiatives, and could be symbols of our green city. Through greening alleys, we can create a healthy environment for people and our ecosystem.



3. SAFER ENVIRONMENT FOR PEOPLE

Alleys are often neglected in Seattle, and sometimes have uneven pavement, discarded items, and dark places for potential crime. While alleys are invaluable for giving service access, additional uses such as retail, cafes, arts venues, and small industry will ensure that alleys are cared for and looked after for a more beautiful and safer Seattle!

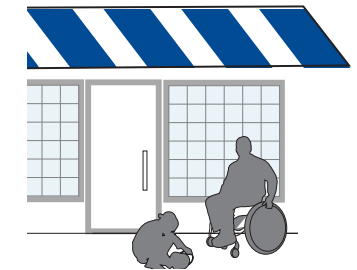

Alley potentials

A MORE WALKABLE CITY

Shortcuts and better city connections, opportunities for alleys to be quieter, safer, and more interesting routes than existing streets.

PLACES FOR GREEN INFRASTRUCTURE

Alleys can be places for bird habitats, local plants, stormwater drainage and other green city initiatives, acting as symbols and catalysts of a healthier more eco-friendly city for all.

INTIMATE AND PERSONAL CITY SPACES

Places to step out of the bustling street, places with birds and plants, and places to sit. Places to lunch with friends in nice weather and meet with neighbors for coffee. Alleys are human scale, and often the back building quality makes them interesting and charming in comparison to streets.

ADDITIONAL STORE FRONTAGES FOR A GREATER ECONOMY

Taking advantage of ground floor spaces on buildings facing alleys gives us denser retail districts, and additional opportunities for entrepreneurs.

PLACES FOR CHILDREN AND THE ELDERLY

These user groups are an important part of city life, but often move at a slower pace and need shade, places to rest, places to play safely, and places for people watching.

OFF-STREET SPACES FOR FESTIVALS AND CULTURAL ACTIVITIES

Activating alleys can provide safe interesting places for festivals and cultural activities in outdoor community environments without taking over streets or parks.

UNIQUE EXPERIENCES

High quality alleys are important; ones with good lighting that feel safe, have good paving, and offer attractions like public art, vegetation, store and business entrances and cafes. They offer a unique experience that can not be found elsewhere in the city.

BY MARKING AN ALLEY WITH A NAME AND AN IDENTIFYING SIGN, A SIGNAL IS GIVEN THAT THE ALLEY IS CARED FOR, SAFE, AND INVITING.

GREEN WALLS TAKE ADVANTAGE OF SUNLIGHT, PROVIDING FRESH VEGETABLES IN THE SUMMER

GREEN WALLS, STORMWATER DRAINAGE, LOCAL PLANTS THAT ATTRACT BIRDS, AND ADDITIONAL ELEMENTS IN THE RENOVATED ALLEYS STRENGTHEN SEATTLE'S ECO SYSTEMS, BUILDING A HEALTHIER CITY.

HANGING LIGHTS CREATE AMBIENCE AND ATMOSPHERE IN THE ALLEY

WHEN THE ALLEY HAS BECOME USABLE PUBLIC SPACE, COMMUNITY MEMBERS COME TO CAFES AND EVENTS IN THE ALLEY

WITH STRONGER CONNECTIONS, OTHER PUBLIC SPACES IN THE CITY WILL BE ACCESSIBLE TO MORE PEOPLE, CREATING A LIVELY PUBLIC REALM NETWORK.

WE CAN USE ALLEYS TO MAKE UP FOR NARROW SIDEWALKS, HEAVY AUTO TRAFFIC, AND FEW PLACES TO SIT IN OTHER CITY STREETS!



What is an alley?

In this handbook, we are specifically interested in city-owned, secondary circulation lanes that have the potential to become great networks of green, safe and social spaces.

An alley is a narrow lane for pedestrians or service that runs between or behind buildings. Alleys used to be planned into cities for trash access, deliveries, electrical, plumbing, and mechanical services, fire engines, and for parking. As a secondary circulation pattern, many pedestrians, cyclists and even autos use alleys for shortcuts or back access.

While alleys vary in width, material, use, and even go by different names in other countries, one thing is certain: alleys not only provide important space for services but also invaluable public space. This handbook is dedicated to the exploration and creative reuse of these overlooked places. With some attention and care, we can begin to transform Seattle into a city that embraces its alleys.

Analysis



Alleys are often forgotten spaces in the urban environment, although they hold great potential. Understanding how they are used, what their potentials are, and what challenges they hold will help to determine what is possible for the future. With some work and care, alleys can be an important layer in Seattle's public realm.

Explore an alley.

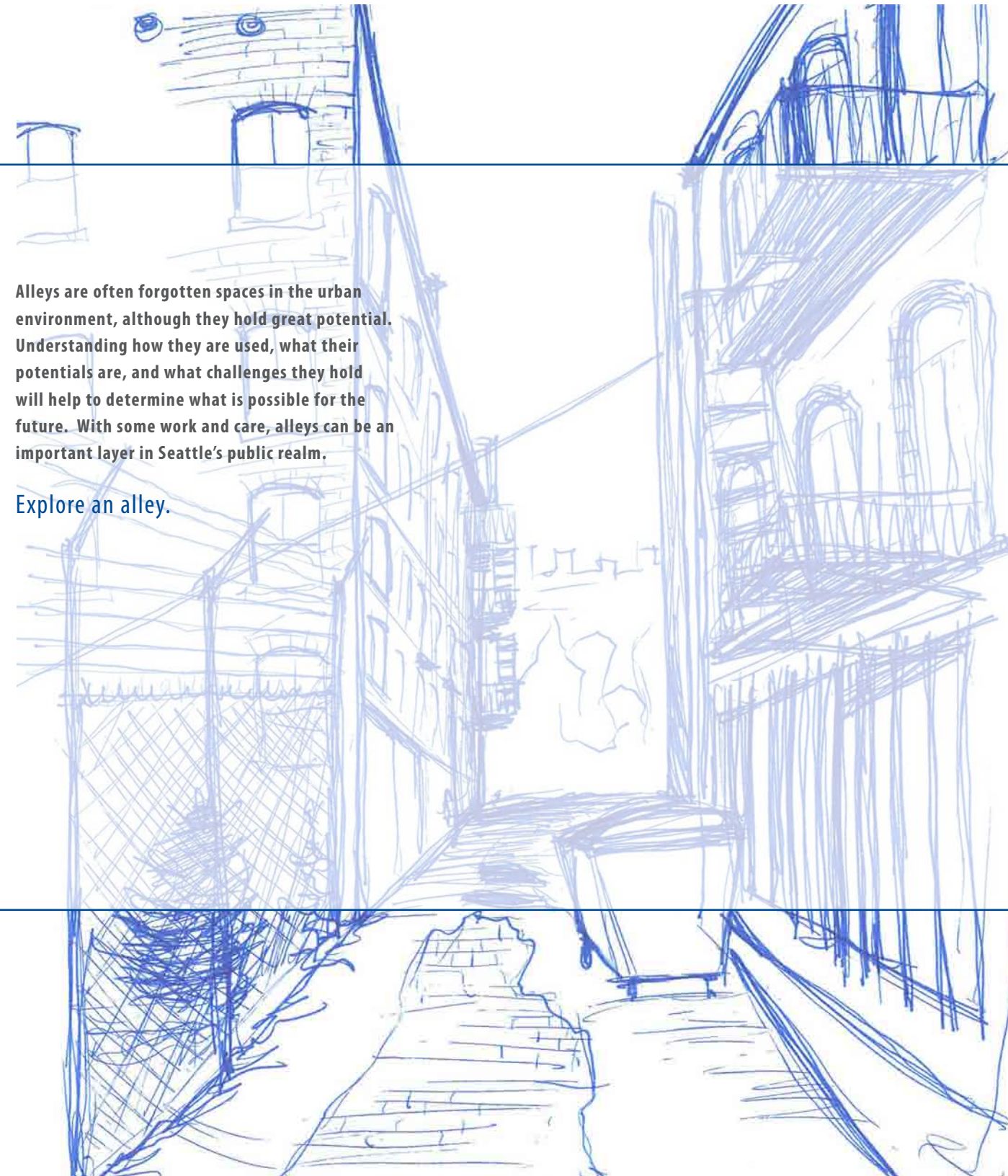

Integrated alley examples

In Seattle and around the world

Existing alleys in Seattle and around the world provide excellent examples of the exciting atmosphere alleys can help create in an urban environment. These special spaces encourage tourists and locals to explore the city, to engage in finding out what a city has to offer. Alleys can easily be part of a green city network, a bicycle network, or a city-wide art program. Alleys offer very different urban space experiences compared to the primary street network, providing intriguing opportunities to explore. The intimate lanes can create a secondary network in the city, with their own separate identities. Much of the character of existing alleys is derived from their origin as service lanes providing access to industrial buildings. Alleys can take on many different identities, bringing the artistic and playful together with the pragmatic. Seattle's Downtown, Belltown, and Pioneer Square alleys have fantastic potential for strengthening the public realm and increasing pedestrian opportunities. The city center's human scale, the quality of materials and the network of lanes represent potential not yet fully realized.

By looking at best practice examples of alleys existing in Seattle and worldwide, we can learn from successes and gain inspiration for our own projects!

SEATTLE ALLEYS

Exciting alleys around our city

CANTON ALLEY

Historic Alley

Canton Alley in the International District isn't the bustling place it once was when the buildings adjacent were tenements for new immigrants. Still, it is a vibrant and colorful alley with shops and back entrances to the Wing Luke Asian Art Museum and theater. The store fronts are inviting, and often groups of people are seen strolling through.

Alleys like this one with cultural significance must be preserved and cared for. Seattle's history is wrapped up in some of these narrow alleys, and possibly our future as well if we can bring new life to alleys like these!



Canton Alley, Seattle



Nord Alley, Seattle



Post Alley, Seattle

NORD ALLEY

Public Space Alley

Led by the International Sustainability Institute, a group of neighbors has come together to make a normal alley into a special community space. Adjacent to Occidental Park, Nord Alley has furniture and plants to warm it up, while still leaving the service corridors open.

During the World Cup, the Tour de France, and other events a large screen is set up for the public. Nord Alley also lights up on the nights of Seattle Art walks, hosting parties and events, making this one of the best kept secrets in Seattle.

POST ALLEY

Market Alley

Pike Place Market is a publicly owned market in the heart of Downtown Seattle, operating booths for local farmers, fishermen, merchants, and craftsmen. Post Alley crosses through the market, and is the most famous alley in Seattle, thriving on the rich culture of the market.

Post Alley is lined with shops, restaurants, cafes, and market stands. Its narrow lanes are perfect for pedestrians, and its texture and color make it one of the most beloved sites in Seattle for both tourists and locals.

WORLD ALLEYS

Innovative inspiration from other cities



Bannam Alley, San Francisco



Melbourne Alley

SAN FRANCISCO

Strong alley identity

Alleys in San Francisco have names, have been painted, repainted, turned into streets, remade into alleys, and are now sometimes streets, sometimes alleys, and sometimes in between.

Bright colors, windows and doors facing the alleys, interesting street frontages, unique names, sidewalks, lighting, and low buildings all help the alleys feel safe, interesting, and welcoming.

MELBOURNE

Interconnected alley network

Alleys in Melbourne have been transformed from forgotten laneways full of debris to a vital part of the Melbourne city plan. Breaking up the large grid, the alleys give pedestrians shelter from the streets, allowing additional opportunities for cafes and shops, and downsizing the urban grain of the city. The alleys give the city a feel of excitement and discovery, allowing for shortcuts.

This use of alleys has strengthened the city, public life and even the economy!

CHICAGO

Green alley initiative

Mayor Daley's Green Alley Initiative in Chicago is among the most progressive in the world. With city funding, alleys are being transformed at an amazing rate to be safer, drain storm water, and green the city.

The alley project is built into a larger vision of green roofs, water systems, and green living infrastructure. With over one hundred alleys completed to date, Chicago is leading the way for green alleys all over the world.

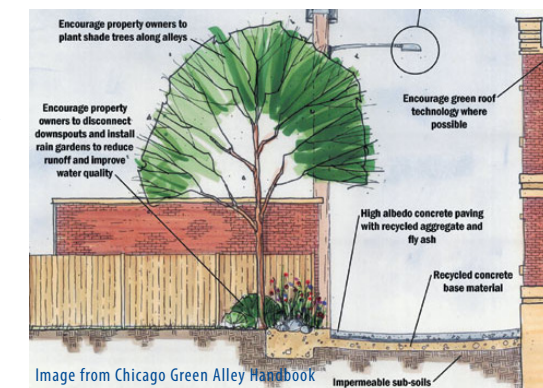

Image from Chicago Green Alley Handbook

GREAT ALLEY TRENDS

NAMES

By naming alleys, we give them identity. From forgotten spaces, they become places in the community.

OPEN FACADES

Doors and windows opening onto alleys are signs of use and safety for pedestrians. Stores and businesses bordering alleys become places of interest, drawing more pedestrians in.

ART AND COMMUNITY PROGRAMS

Art in alleys, and other community programs also show that alleys are a cared for and safe part of the community. Many cities use blank alley walls as canvases to showcase local muralist talent.

GREEN CITY INITIATIVES

Adding plants, using alleys as part of a larger water drainage system, and creating native bird habitats are common strategies in cities renovating alleys used while making the city more sustainable.

PLACES TO EXPLORE

Great alleys are places for locals and tourists to discover hidden treasures'- a perfect summer reading spot, a wonderful coffee shop, a favorite store.

Many of these trends rely on giving the impression that alleys are cared for places. When alleys have this quality, they will feel safe and inviting to pedestrians!

Successes in Seattle's alleys

Seattle alleys already possess key elements that can be celebrated and strengthened to make successful public space. In the quest to understand the Seattle alley network, a range of data was collected in nine neighborhoods spanning many types of alleys. This data has allowed us to recognize some positive qualities within Seattle alleys.

Some successful alley features to consider include: walking conditions, pedestrian presence on surrounding streets, the existence of lighting, human scale, the presence of businesses and stores around alleys and interesting building facades.

Challenges in Seattle's alleys

Alleys are a unique aspect of the city that are often neglected or are only used for one specific purpose. In the data we collected, there are many elements that could be re-thought to contribute to the quality and enjoyment of alleys in the public realm, connect systems of infrastructure, while also serving necessary city needs.

Some of the problems we see in the alleys today include: a focus on cars and trash service as main use, low invitation for interaction, few positive night activities, an abundance of garbage containers, low functioning drainage systems, and little plant life. By addressing these issues, alleys can become more than service links for the city and incorporate multiple uses.

Successful



Walking Conditions

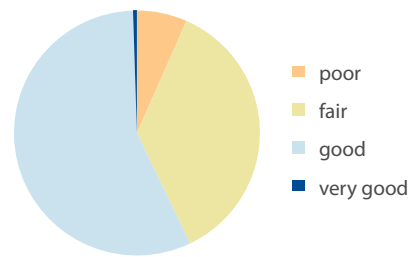

Pedestrians the streets

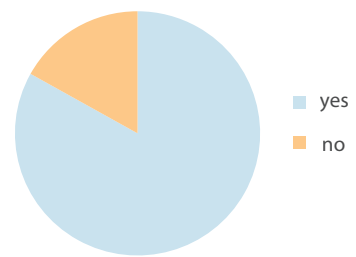

Existence of Lighting

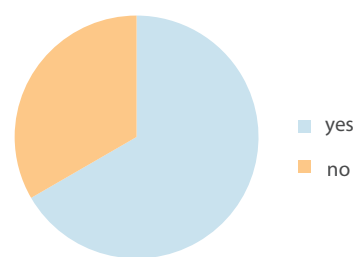

Invitation for interaction

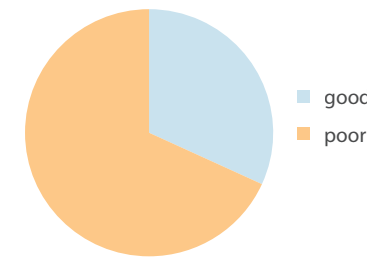

Existence of trash containers

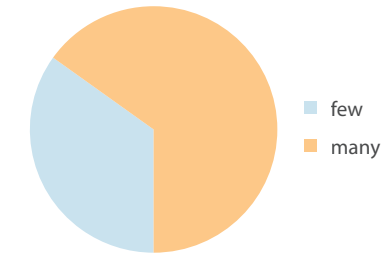

Existence of plants

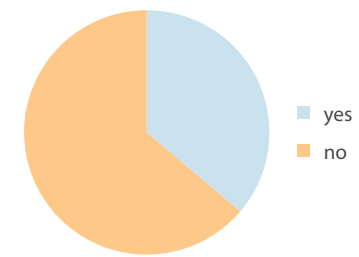

Human Scale

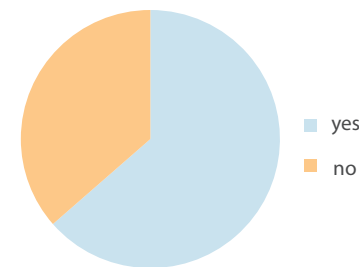

Existence of businesses

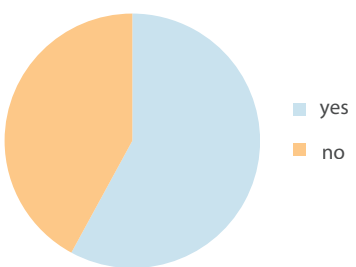

Building Facade Quality

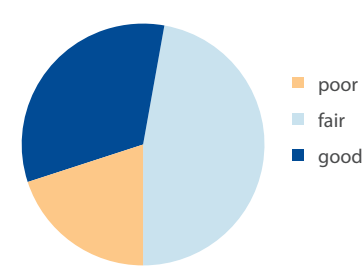

Primary alley use

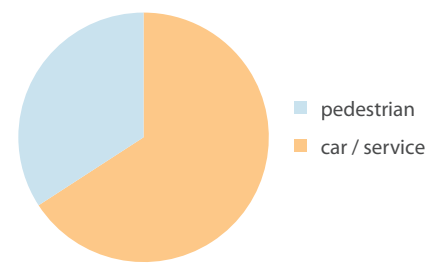

Existence of positive night activities

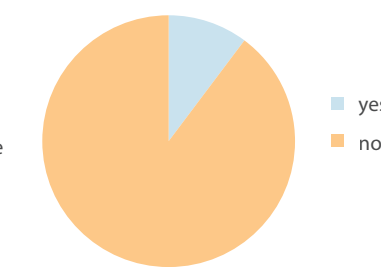

Existence of drains

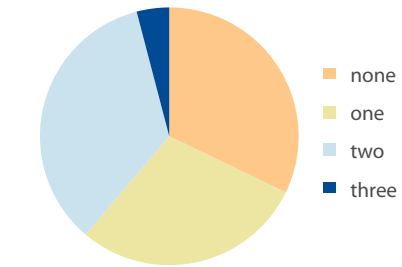

Unsuccessful

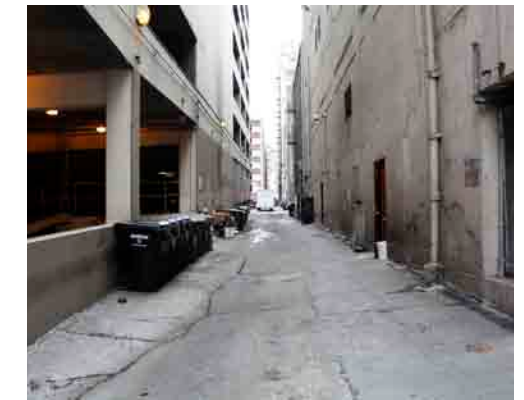

What type of alley do you have?

There are a variety of alley types and uses throughout Seattle, which can make it challenging to identify what qualities and innovations might help improve your alley.

After our analysis in Seattle, we categorized alleys into six different types based on surrounding use and function. These categories can help you to determine what type of alley you might be working with and what elements might work best to produce an exciting, functional, and context-specific space.



High Density Mixed Use

These alleys are often deep due to tall surrounding buildings, and have many surrounding uses including offices, residential, restaurants, retail, and parking. They often act as pedestrian passageways and areas for temporary parking and are key to bringing services into the buildings they border.

Often found in Downtown, Belltown, and Pioneer Square neighborhoods of Seattle.

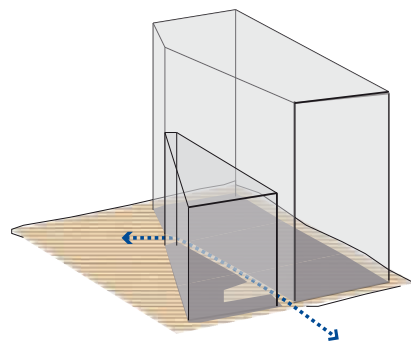

Low Density Mixed Use

These alleys also serve residences, restaurants, offices, services, retail, and more, but with lower buildings and occasionally empty lots. They often have areas for parking, plants, gardens and generally receive more sun during the day due to lower building heights. These are also excellent places for cafes, stores, and public space.

Often found in Ballard, Capitol Hill, First Hill, and the International District neighborhoods of Seattle

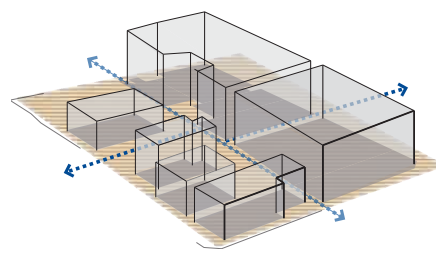

Nightlife district

Bordering on bars, clubs and restaurants, these alleys are spaces that can activate the times after dark. They often are pedestrian passage ways at night and have the potential to extend businesses by allowing for additional exterior space.

Often found in Pioneer Square, Capitol Hill, Downtown neighborhoods of Seattle

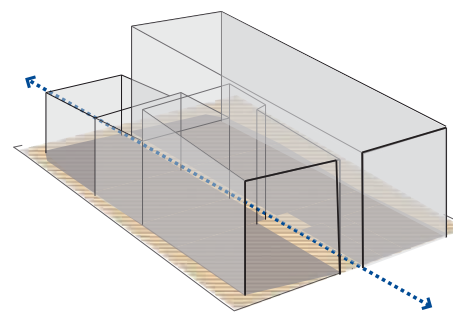

Commercial District

Alleys in the commercial district are filled with active retail and space for potential businesses of all types. These alleys can help to expand local business communities and open up new storefront opportunities in retail cores.

Often found in Capitol Hill, Belltown, Downtown neighborhoods of Seattle.

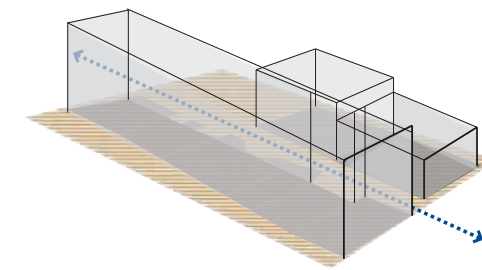

Multi Family Residential

Residential usage in adjacent multi-unit buildings characterize this type of alley. They have the potential to become gathering spaces and additional pedestrian passages in neighborhoods with many families.

Often found in the International District, Yesler Terrace, and Capitol Hill neighborhoods of Seattle.

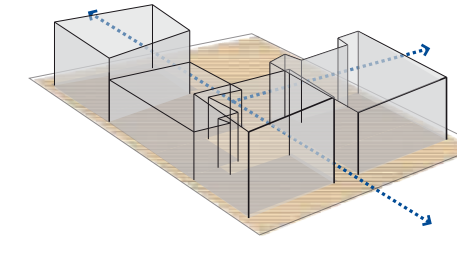

Single Family Residential

Alleys in the single family residential category are spaces that separate the backyards of houses, but could also be connecting points within and between blocks. They also are ripe for potential green infrastructure, providing space for wildlife, walkers, and bikers.

Often found in Ballard, Columbia City, and many other residential neighborhoods of Seattle.

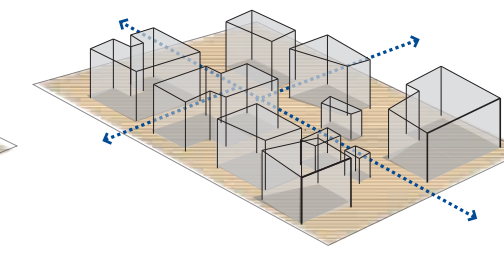

Recommendations



How can you help improve your alley?

as a designer...

Alleys offer a great opportunity for designers to influence the urban environment. Design professionals have the skills to recognize the qualities and characteristics of potential great alleys. Collaborating with city officials, business owners and citizens, designers can help to create new and exciting environments in the city, while also raising the standards for our public spaces.

as a business owner...

As a business owner, alleys can be an asset to business expansion and commercial connection within the community. Improving the areas around your business could attract more customers and clients and provide opportunities for expansion outside into the alley space. Transforming alleys could have other benefits for businesses too, such as providing community hotspots and creating cohesion among adjacent businesses.

as a city official...

Alleys are usually owned by the City. The process of implementing new features and uses into alleys could be facilitated with the support of city officials and planners. The transformation of alleys will provide some positive results, strengthening public spaces within the city environment and helping to achieve goals such as stormwater infiltration. City officials can help to address issues and to streamline the alley transformation process.

as a citizen...

Alleys are public amenities and can provide space for residents to influence their neighborhoods. By taking a role in alley improvements, you can enhance the type of activities available and the quality of your neighborhood, making it a more positive space to live, work, and play. These transformations can create a solid community where people take responsibility for quality of public space.

Compared to other public spaces, alleys have unique shapes, sizes, and qualities in the city. With some creative thinking and a little work, simple solutions can transform an ordinary alley space into an extraordinary public amenity. It is time to take advantage of these spaces and add a new layer of urban life to our city.

Be inspired to re-create your alley.

Post Alley in Seattle, WA

What are the keys to successful alleys?

Our goals are to make a great public realm, safe spaces, and a healthier more beautiful city, simply by activating alleys within the urban environment!

Quality of public space

- People should be able to stop and enjoy spaces off of busy city streets.
- Alleys should be part of a city's identity, not neglected 'back-side' spaces.

Ecological health of the city:

- Alleys should contribute to healthy functioning ecosystems of a city, providing corridors for movement and habitats for plants, insects, and birds.

Safer environment for people:

- Alleys should be safe at all hours
- All people should be able to safely use alleys.

With the following improvement components, alleys can begin to support more life and uses. The following ten categories take a look at the big and small changes that can be made in buildings, ground, environment, water treatment, atmosphere and safety of alleys. While not all of these ten improvement areas will be applicable to every alley renovation project, each effort promotes higher-functioning alleys.

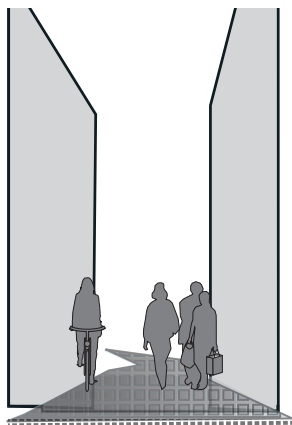

1. Paving

New paving makes some of the highest impacts in alley improvement. It is important to choose new pavers for their environmental impact, material, and strength, as well as color and style. Materials should be strong enough to withstand the loads of necessary service trucks.* They should also be as permeable as possible—such as tiled pavers rather than asphalt or concrete**. This allows water to drain into the ground to filter and retain runoff instead of conveying polluted water into the street drains.

High albedo or reflective materials help to reduce heat in the summer, and recycled materials reduce the footprint of the project and are usually more cost effective.

*Often a mix of pavement types is most effective. Concrete where truck wheels go, and pavers elsewhere.

**Permeable pavement is only desirable when there is no contaminated soil beneath.

Costs vary dramatically due to materials and work necessary.

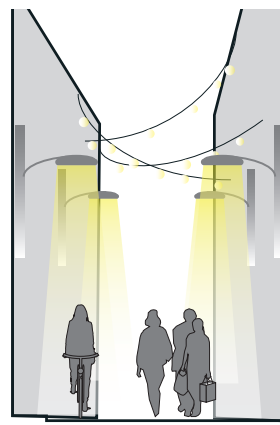

2. Lighting

Providing good lighting in alleys is imperative to maintaining safe alley environments. Well-lit alleys discourage crime, encourage pedestrians, and can introduce artful elements.

When choosing new fixtures, make sure they are specified for outdoor use. Also, choose dark sky compliant fixtures to avoid light pollution at night. LEDs are another low-energy lighting option.

Another important aspect of lighting is the ambience it brings to a space. Adding softer lights, creating spaces with lighting, and playing with lighting temperature can bring new life and atmosphere to an alley.

Costs vary dramatically due to various light fixtures and amount of electrical work needed.

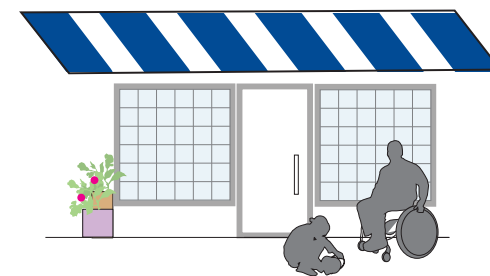

3. Canopies

Canopies are a low-cost option for spatial reconfiguration in alleys. They create intimate spaces for people, bring protection from rain, snow and other elements, and bring interest to alleys. Canopies draw attention to entrances, bringing more visitors into alleys, and creating comfort within the alley. Alleys are long, narrow, and often tall spaces, so canopies are instrumental in creating spaces that feel more comfortable and intimate.

They must be placed high enough to retain access for services, but low enough to keep rain out.

Many standard variations are available at a range of costs.



4. Plants

Adding robust and attractive plants to alleys is one of the fastest and most effective ways of making a noticeable difference. Plants will help improve the air quality, atmosphere, and increase the inviting feel of an alley. Finding the right plants for existing sun and shade levels as well as wind and weather patterns will help ensure plant survival. Use of native plants will help to provide new bird and insect habitats, strengthening Seattle's urban ecosystems.

Edible alley gardens can also be planted, incorporating herbs and vegetables. Plants help filter water and absorb and process pollutants. The simplest solutions are potted plant gardens and window boxes.

Ranges depending on plants and planters.

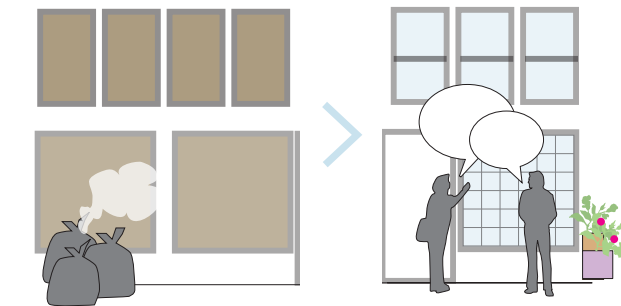

5. Opening Facades

Many of the facades facing alleys in Seattle were built with windows and doors that have now been boarded over or blocked in. Reopening these facades and also constructing any new facades with windows and doors will help improve the quality of space within alleys.

Transparency and access between inside and out will mean that more people are aware of what is happening in alleys, creating greater safety. With improved safety, more pedestrians and cyclists will use alleys as secondary entrances, and businesses will be able to open within alleys, providing yet more 'eyes on the alley'.

This process could be as simple as removing plywood or replacing windows. Other types of work will likely require an architect or engineer.

Can be extremely expensive. Consult with a structural engineer.

Rain in Seattle a major challenge

Rain in Seattle is ubiquitous for many months of the year. Currently, our methods of handling stormwater runoff are causing problems that have significant adverse impacts on our local aquatic ecosystems. By designing our streets and buildings with a little more care, we can easily reverse the process and benefit from the abundance of fresh water we receive annually.

By collecting and filtering rain water and urban runoff, we can reuse it to reduce our demand on Seattle's drinking water source, redirecting it to water plants and gardens. Or, we can drain it back into the soil instead of the Sound, recharging the groundwater that keeps our streams flowing in the dry months.

Alleys can be an important part of this process. Many of our alleys need a makeover, and considering drainage and water treatment when making these changes could mean that simple steps taken during construction can make a very large difference in the overall health of our eco systems.



6. Identity

Alleys with names, art, businesses, public landmarks or points of interest that can be indicated on maps are much more accessible for use than alleys that don't have these characteristics. This is because it is difficult to go to a place that one doesn't know about. Because the alleys in Seattle don't have names or separate identities, they often aren't considered part of the city street grid.

Through the simple act of giving alleys names and placing plants and furniture in them, an invitation is offered to the rest of the city to enter, and a statement is made that alleys are a part of our city.

Naming can be free. Consult your neighbors.

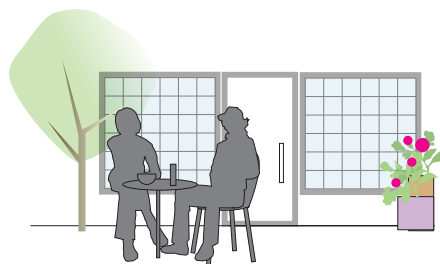

7. Furniture

Furniture is a way to reclaim alleys for pedestrians and public space. Alleys are great places to locate bike racks off streets and sidewalks and can be sheltered from the elements. Cafes could open for lunch after morning service trucks have completed their deliveries, providing movable tables and chairs for customers. Other benches, chairs, and tables could make small urban resting areas; cycling stations with air and other services could be conveniently located in alleys; and recycling centers are also better located in alleys than on streets and sidewalks.

By activating the underused space in alleys, we can improve our quality of life while maintaining clear sidewalks.

Cost varies depending on quality and permanence of furniture.

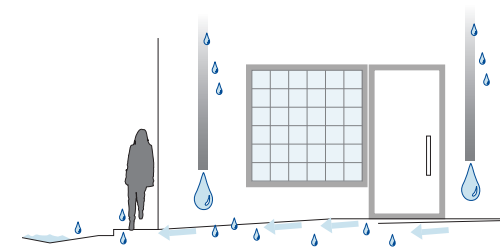

8. Water run-off

Dealing with water in Seattle is a big part of designing the urban environment. If repaving an alley, it is important to make sure it is pitched properly for water runoff to streets.

Often roofs drain into alleys, or bypass directly into the sewage system, causing overflow in storms or taking polluted water to our lakes, streams, and bays. It is important to deal with water on site as much as possible to avoid sewer overflows and pollution.

Free with proper paving.

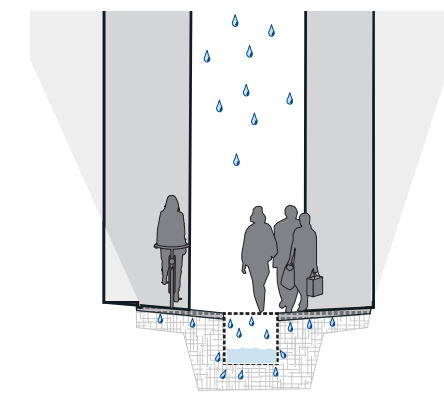

9. On-site water treatment

A popular solution used in many cities for dealing with water runoff is on-site filtration into the soil.* An engineer or landscape architect is usually needed to determine if this is a feasible solution for a particular alley. In less dense alleys, such as residential alleys in Ballard, permeable paving and bioswales are potential ways to filter water through soil and plants.

Drainage channels can be open or closed and permeable or not depending on conditions, and can be easily located on the side of the alley, rather than in the middle.

In more urban environments, permeable pavers can filter water to soil below, and structured drainage channels can collect and treat water and let it filter more slowly into the ground or temporarily hold it to reduce downstream flooding.

*This is not desirable when soil below alley is contaminated unless the swale or channel bottom is lined with an impermeable layer.

Often cost prohibitive.



10. Water collection

A last option for dealing with water in Seattle alleys is rainwater collection and re-use. On site water collection and filtration is especially useful if there is an adjacent garden to the property. The water can be reused for roof gardens, and any other plant irrigation. A secondary option is to use this stormwater as a source for non-potable water in your home or business, such as toilet water.

There are many existing available systems that can be used, such as rain barrels available from the City. A qualified architect, engineer, or contractor can be hired to design a custom system.

Cost varies depending on scale.

High Density Mixed Use Alley

This downtown alley is situated next to a large public square and borders several businesses, office space, and residential apartments. It contains commercial activity at both ends and acts as a thoroughfare for both people, vehicles making deliveries, and cyclists.

This complex alley could become an extension of the existing public space, providing a secondary route for pedestrians travelling to and from the main commercial core. Some key changes include an introduction of lighting, planting walls to change the character and opening facades for potential small scale businesses.

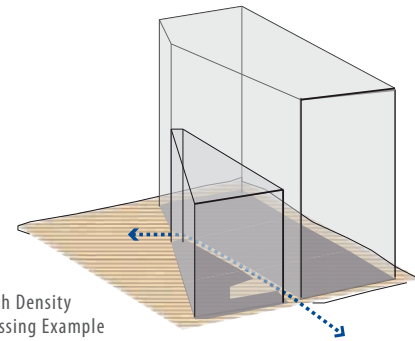

High Density Massing Example

Before



Changes made to alley space

- Opening facades bring the space down to human scale adding activity, color and comfort.
- Integrating art and character brings life and identity to the alley.
- Shade plants bring in new texture and color.
- Paving connects with the existing public space adjacent to the alley.
- Addition of lighting makes the deep alley feel brighter and more inviting.
- Activity of the adjacent square can spill into the alley creating spaces of entertainment and excitement.

After



Low Density Mixed Use Alley

A mix of residential apartments on one side of the alley and low scale businesses on the other provides a unique opportunity to combine multiple uses. This alley can bridge both the commercial components of the neighborhood and become a community space for residents.

Some key improvements in this type of alley include creating some extensions of present commercial activities, developing rain gardens with existing planted areas and bringing in furniture and seating for daily and evening activity.

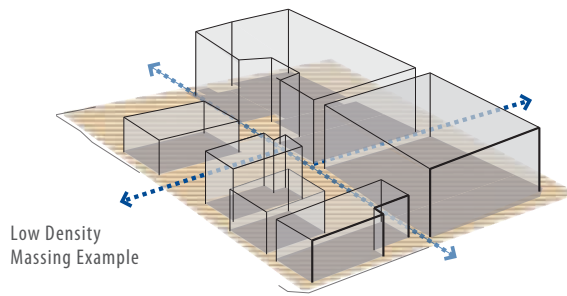

Before



Changes made to alley space

- Outdoor furniture, lighting and seating invite people into the alley.
- Opening facades creates transparency between the indoor and outdoor spaces giving new opportunities for businesses.
- A name for the alley gives it greater power in the community.
- New permeable pavement replaces existing asphalt, bringing character to the space while providing water infiltration.
- Canopies and covering bring shade and comfort to the alley space by creating a more human scale experience.
- Create identity for the alley by incorporating art and local character.



After



Nightlife District Alley

This alley in Pioneer Square leads to a public park and borders several bars, restaurants, and nightlife spots. It is important for this alley to be safe at night, and as lively as the nearby scene, while taking its historic roots into careful consideration.

Permeable paving to help water drainage, appropriate plants, and the reopening of facades to create connections to the spaces within are key changes for this alley. With some care and planning, this is an alley that can be an important part of the neighborhood, and a draw in itself.

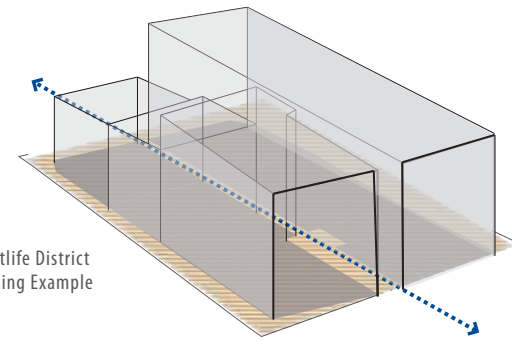

Before



Changes made to alley space

- Blank walls can be used for street art, bringing color and culture to the alley for a brighter community.
- A name for the alley gives it greater power in the community.
- New lighting fixtures bring atmosphere and excitement to the alley, inviting new comers in.
- Plant shrubs, vines, herbs and vegetables to take advantage of sunlight.
- Open blocked in walls, and add canopies to create shade and space.
- Capitalize on destinations at ends. Add signage directing pedestrians to destinations.
- Furniture in the alley extends the park, and gives visitors a place to stop and stay.

After



Commercial District Alley

This alley is in Belltown, a historic brick neighborhood in Seattle. A wide variety of buildings, a dog park, existing trees, interesting facades, and several businesses and restaurants give this alley interesting renovation potential.

Key changes to make are reopening the facade, turning parking spaces into a bicycle parking lot, celebrating the differences in the buildings and the unique spaces they create along the alley, and promoting the existing businesses surrounding the alley, while opening opportunities for businesses to join the district.

Before

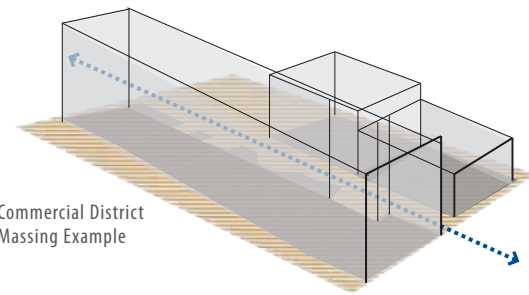

Commercial District
Massing Example

Changes made to alley space

- Existing dog park can become more integrated into alley, with gates directly from the alley to the park.
- Growing plants on the fence could make it appear less harsh.
- A name for the alley gives it greater power in the community.
- New lighting fixtures bring atmosphere and excitement to the alley, inviting new comers in.
- Plant shrubs, vines, herbs and vegetables to take advantage of sunlight. Take care of the existing trees providing shade.
- Open up blocked in walls, and add canopies to create shade and space.
- Existing windows should be maximized, with the spaces behind rented out to users with interesting or unique functions.
- Removing trash cans and dumpsters helps the alley feel more open and inviting.

After



Multi Family Residential Alley

This alley has many families living next to it, in a dense urban neighborhood. It is a connecting alley as many people use it as a short cut even though it has a steep slope. Safety and a sense of community are most important to alleys like this.

Key changes are:

Reopen the facades where they have been boarded up, to create a safer and more shared environment.

Add interesting lighting for safety and to make a fun family environment.

Public art on blank walls can help increase the sense of community.

Places to sit at the top of the slope will be beneficial for the elderly who use the alley to reach their homes.

Addition of bike parking will encourage family members to cycle as a mode of transportation.

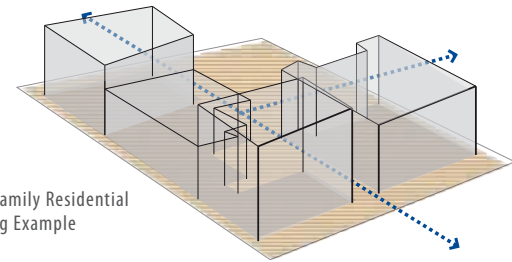

Multi Family Residential
Massing Example

Before



Changes made to alley space

- Existing parking lot can become bike parking, and create more paths to key areas in the neighborhood.
- Empty walls can be used for street art, bringing color and culture to the alley for a brighter community.
- A name for the alley gives it greater power in the community.
- New lighting fixtures bring atmosphere and excitement to the alley, inviting new comers in.
- Plant herbs and vegetables to take advantage of sunlight.
- Open blocked in walls, and add canopies to create shade and space.
- Existing garden can be converted to rain garden to treat on-site water runoff from buildings and pavement.

After



Single Family Residential Alley

Less dense neighborhoods of Seattle have some unique alleys that are potentially beneficial to ecological connections and could serve as public space for surrounding residents. This alley in the Ballard neighborhood of Seattle could incorporate a range of green infrastructure elements that would allow it to work into the larger systems of stormwater control and habitat corridors.

Key changes include new permeable paving, conversion of surrounding growing areas into rain and urban habitat gardens, and water retention basins that will help to improve the water quality of run-off draining to Seattle's waterways.

Before

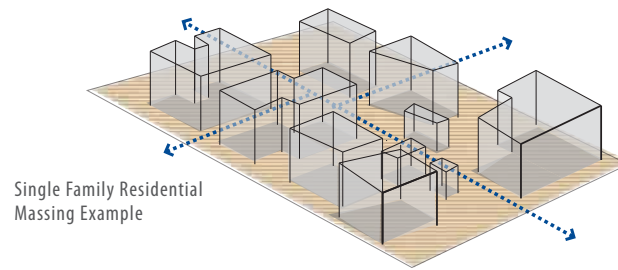

Single Family Residential
Massing Example

Changes made to alley space

- Planting for rain gardens and bioswales will help with on site water infiltration.
- New permeable pavement provides water infiltration and also an upgraded surface for walking.
- Hardy shrubs, vines, herbs and community gardens create new green corridors and potential habitat.
- Connect residential green infrastructure systems through the use of cisterns and open drainage channels.
- Urban agriculture and community gardens provide life to the alley and can connect neighbors.

After



Considerations for alley renovations

While renovating your alley, keep in mind that our objective is to make great public space, safe spaces, and a healthier, more beautiful city, through careful consideration and renovation of the alley network.

The following steps show ways of combining innovative components to different effects. The approaches are broken down as simple, moderate, and substantial renovations, but the combinations of innovations are endless. Make sure to use your imagination, and follow the innovations most important to you! Keep the goals of the alley network in mind, and do as little or as much as you can. Keep in mind that often groups of like-minded people can get much more accomplished than an individual.

Simple renovation

This idea breakdown shows how to change an alley with simple steps anyone can take. This option does not require much professional assistance, and all of the steps can be taken in a frugal manner. Improvements like these show that an alley is cared for, and impart a sense of safety to pedestrians. If a group of neighbors agrees to take these steps together, an alley will be transformed!



Steps toward alley improvement:

Quality of public space

- Create atmosphere through simple canopies
- Give the alley a name
- Make public artists and art initiatives welcome.
- Create events for people to join

Health of the city:

- Plant pots and add window boxes with native plants

Safer environment for people:

- Make sure the alley is clean and well lit

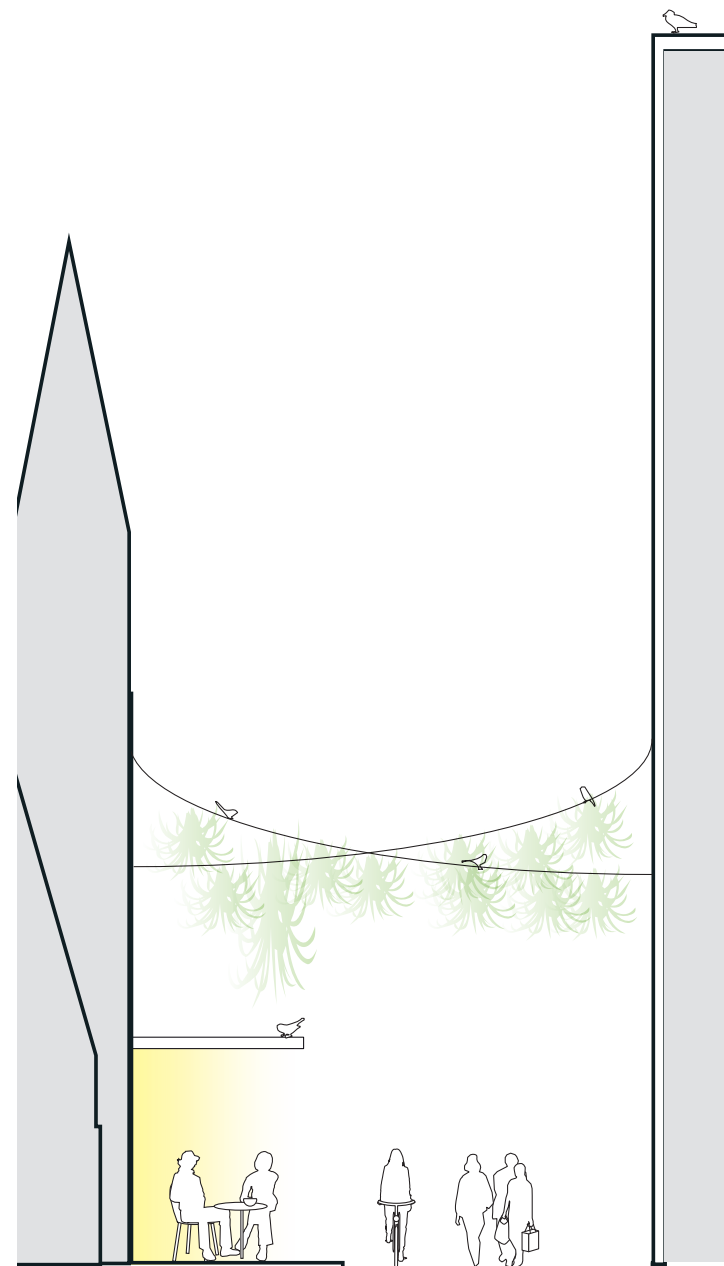
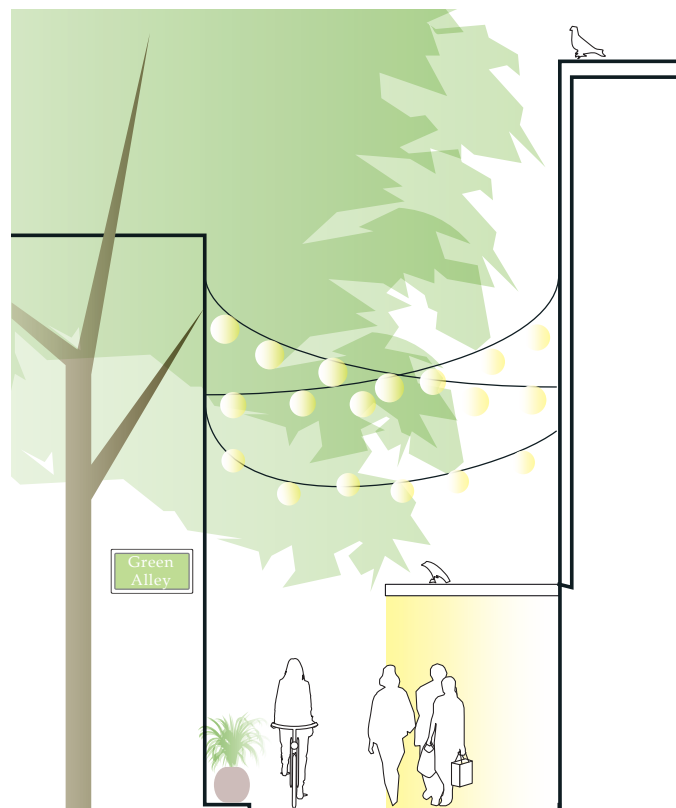

Steps toward alley improvement:

Quality of public space

- Retractable canopies are weather and season responsive.
- Give the alley a name
- Make public artists and art initiatives welcome.
- Open buildings to invite cafes
- Add places to sit
- Create events for people to join

Health of the city:

- Plant pots and add window boxes with native plants
- Permeable pavers let weather through

Safer environment for people:

- Make sure the alley is clean and well lit
- Consistent paving is key to safety, and creates surfaces that the disabled, children, and the elderly can feel comfortable on.

Moderate renovation

This approach shows how to change an alley with some contractual work necessary. This option will require some professional assistance. This is a step up from a simple alley in that materials and buildings are actually changed to make the alley safer, more beautiful and therefore more inviting. Worth the effort, this alley is sure to become a beautiful and interesting public space for the community.



Moderate renovation

This approach shows how to change an alley with some contractual work necessary. This option will require some professional assistance. This is an alley focusing on water systems and a greener environment. This type of work will also make for a beautiful, safer, more people-friendly alley as well. Rain gardens and drainage channels are best designed and installed professionally.



Steps toward alley improvement:

Quality of public space

- Give the alley a name
- Make public artists and art initiatives welcome.
- Create events for people to attend

Health of the city:

- Plant pots and add window boxes with native plants
- Drainage channels help filter the water into the soil below, preventing water runoff
- A rain garden also helps filter the water back into the water table, using plants to remove toxins first.

Safer environment for people:

- Make sure the alley is clean and well lit
- New paving around the drainage channel is key to safety, and creates surfaces that the disabled, children, and the elderly can feel comfortable on.

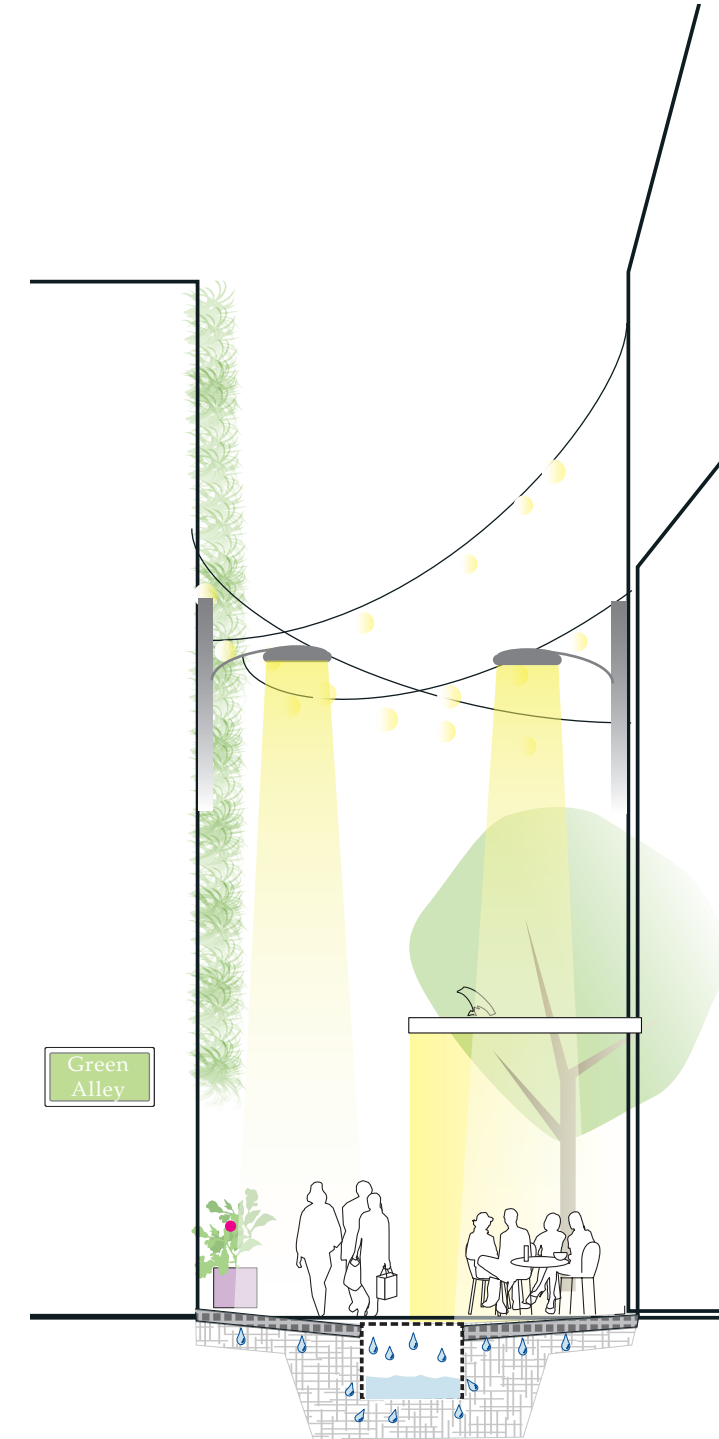

Steps toward alley improvement:

Quality of public space

- Retractable canopies are weather and season responsive.
- Give the alley a name
- Make public artists and art initiatives welcome.
- Open buildings to invite cafes
- Add places to sit
- Create events for people to attend

Health of the city:

- Plant pots and add window boxes with appropriate plants.
- Permeable pavers let weather through.
- Drainage channel helps filter the water into the soil below, preventing runoff

Safer environment for people:

- Make sure the alley is clean and well lit
- Consistent paving is key to safety, and creates surfaces that the disabled, children, and the elderly can feel comfortable on.
- More shops and people mean safer active spaces for pedestrians and businesses.

Substantial renovation

This approach shows a full alley renovation. This option will require professional assistance. This alley is a great public space while fully participating in the green city network through plant and water systems. Materials and buildings are actually changed to make the alley safer, more beautiful and therefore more inviting. This alley is an active and interesting public space for the community, attracting visitors and locals alike.



Next Steps



With any type of redevelopment, large or small, it is important to make a plan of action. To get started, we need to create strategies for reinventing alleys in the city, ranging from the small scale improvements to the city wide scale. It starts with a few small steps but together we can make large strides towards a more beautiful Seattle.

Take a role in improving an alley.

In the transformation of Nord Alley from a filthy forgotten space to a place of public celebration, what's been most heartening is that the effort to make a place for the community has strengthened our community itself. Neighbors have poured in the streets to contribute their diverse enthusiastic talent for making our space thrive.

Todd Vogel, International Sustainability Institute

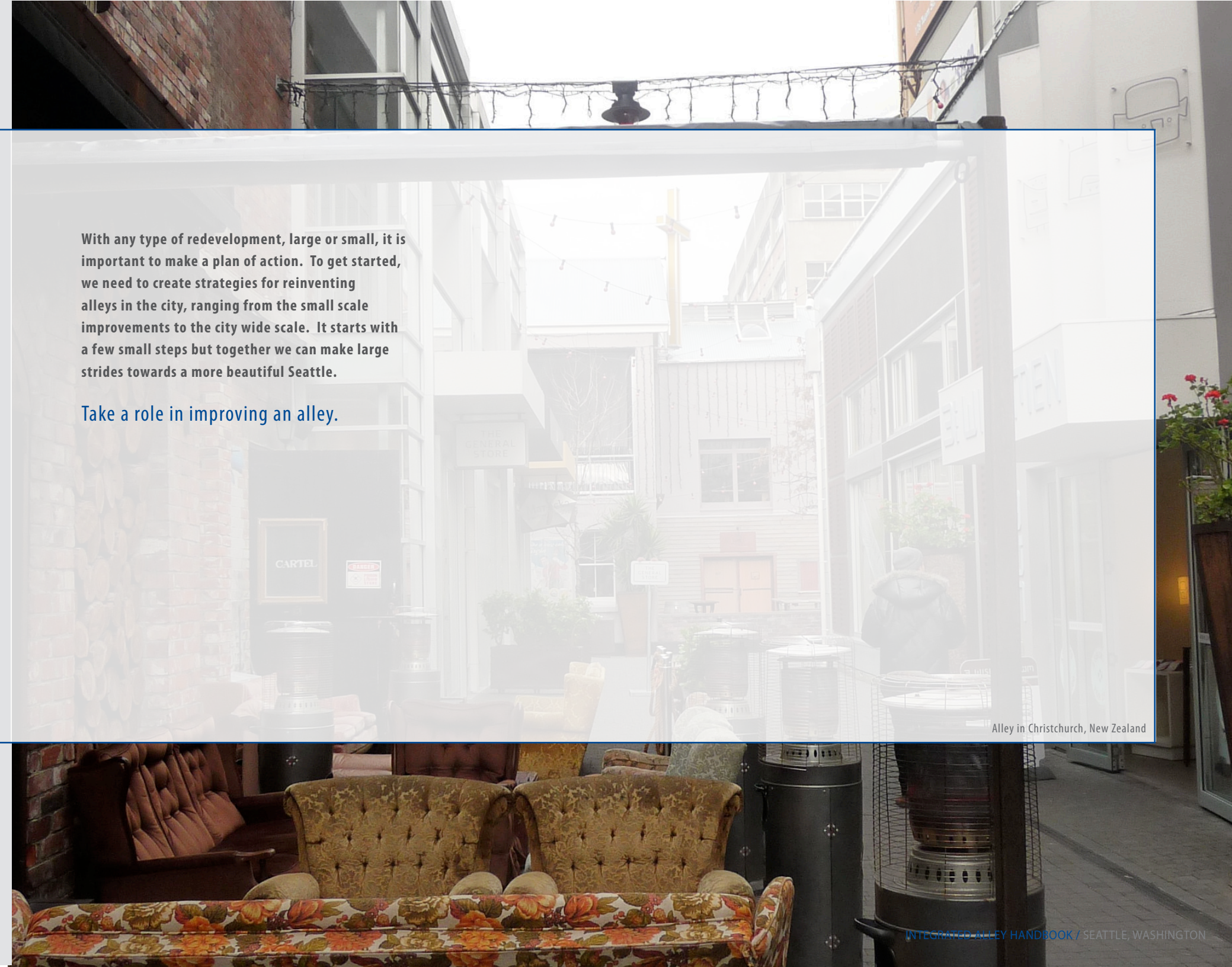

Alley in Christchurch, New Zealand

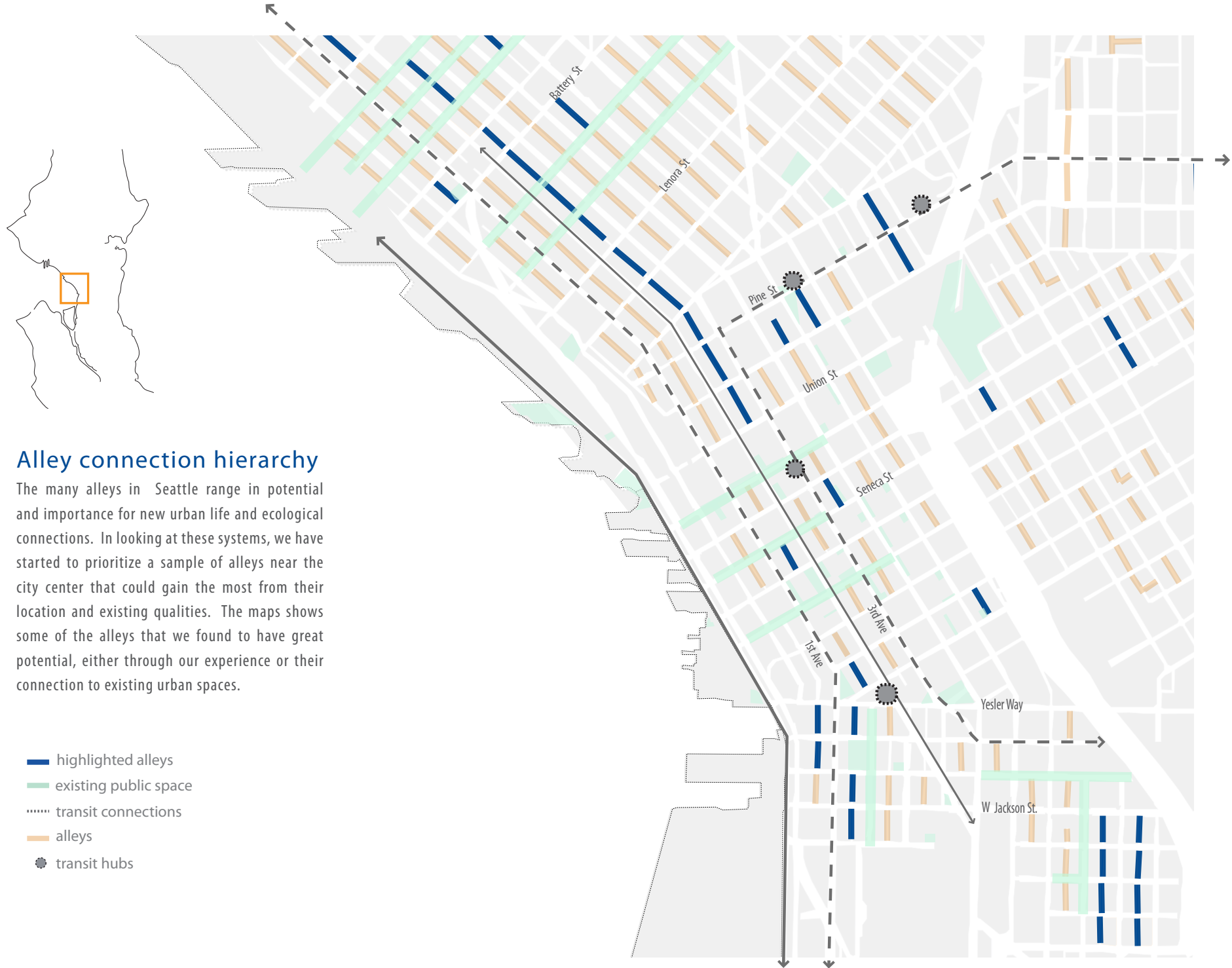

Alley connection hierarchy

The many alleys in Seattle range in potential and importance for new urban life and ecological connections. In looking at these systems, we have started to prioritize a sample of alleys near the city center that could gain the most from their location and existing qualities. The maps shows some of the alleys that we found to have great potential, either through our experience or their connection to existing urban spaces.

- █ highlighted alleys
- █ existing public space
- ⋯ transit connections
- █ alleys
- transit hubs

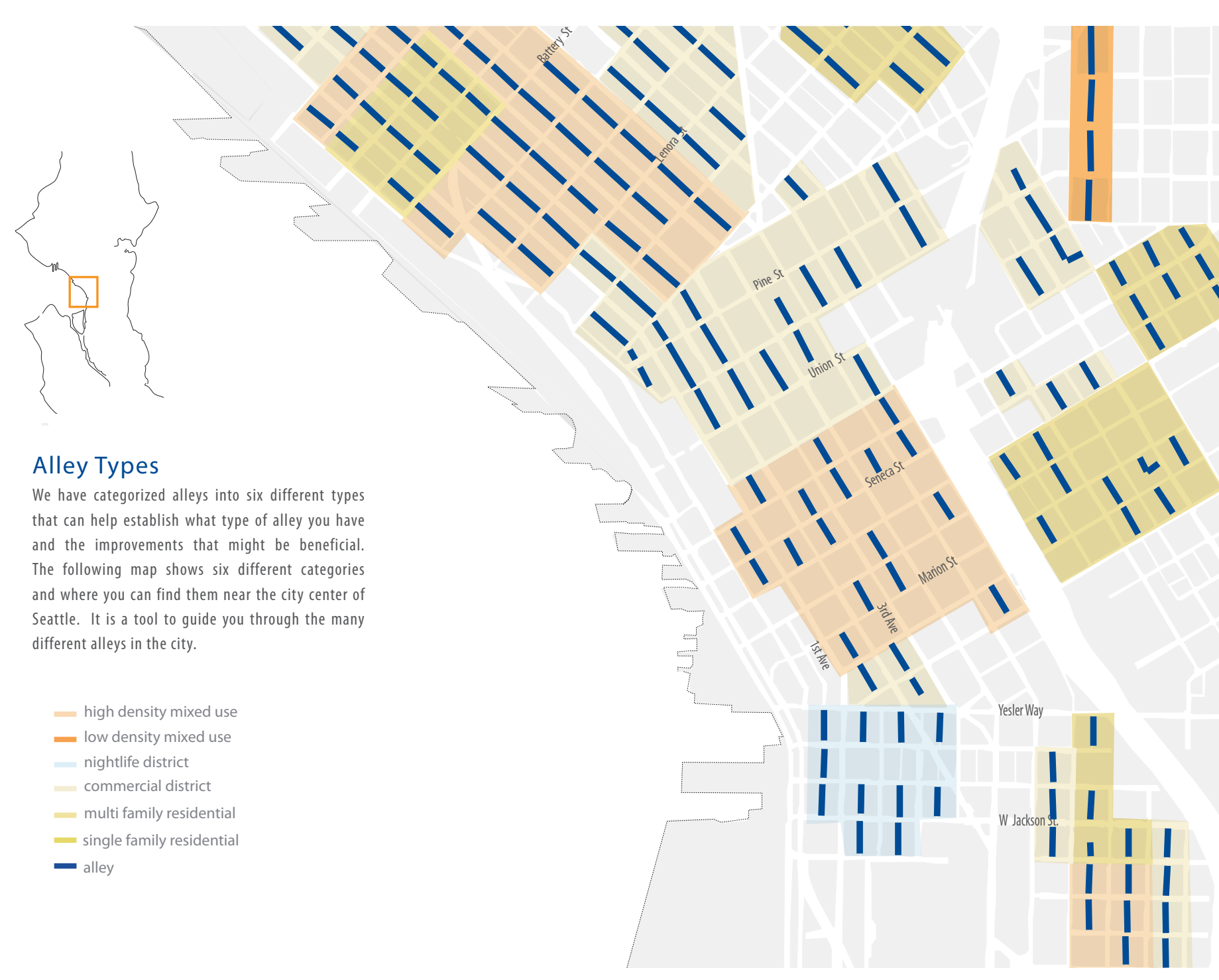

Alley Types

We have categorized alleys into six different types that can help establish what type of alley you have and the improvements that might be beneficial. The following map shows six different categories and where you can find them near the city center of Seattle. It is a tool to guide you through the many different alleys in the city.

- █ high density mixed use
- █ low density mixed use
- █ nightlife district
- █ commercial district
- █ multi family residential
- █ single family residential
- █ alley

Day in the alley life

Integrating multiple functions into an alley can be easy with a little planning. Thinking about maintenance schedules, commuting times, events and activities can help alleys become the true public amenities that they are for the city.

Alley can be very dynamic places, bringing many types of users together in one little strip of space, creating some very interesting corridors and nodes for the city.

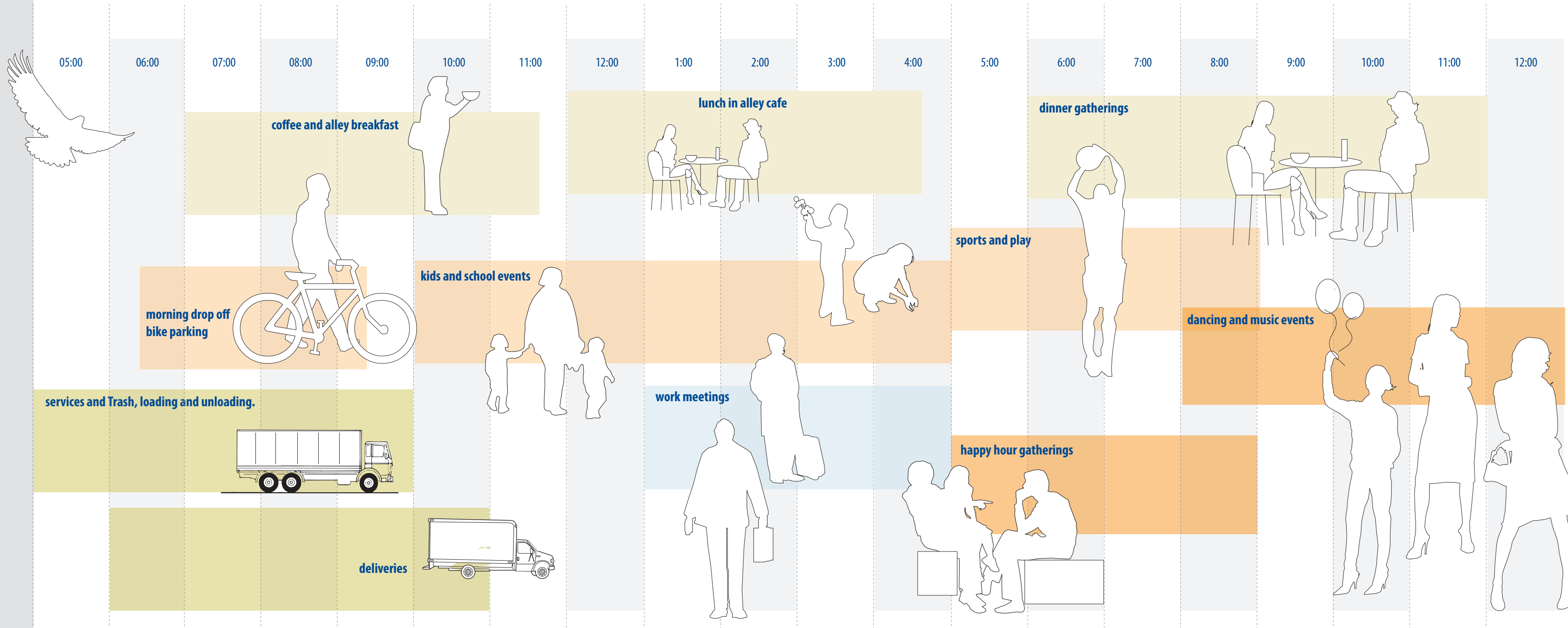

Seattle is an exciting vibrant city. As with all cities, analysis and improvements help the city continue to meet its needs. A holistic integration of public space, infrastructure and ecological systems is important in keeping a city's systems and networks functioning to their full potential.

This is where the alleys of Seattle come in. Alleys have long been overlooked in Seattle, ignored by most residents and visitors, and often viewed as just the backsides of buildings. They are typically considered to be merely places for services and unloading. Yes, alleys hold many possibilities for the creation of a safer city, places for people to be outdoors, additional business opportunities, environmental and ecological strategies, better water treatment, and a more beautiful city.

Imagine ducking into the alley behind your building to grab a pastry and a cup of coffee from a cheerful morning vendor on your way to work. Your neighbors are seated on wood cafe chairs that the vendor places in the sunshine in front of vibrant murals by local artists.

You can smell the pizza shop next door getting ready for the lunch rush, and down the alley a neighbor tends his shade garden. Perhaps you've brought out your recyclables to sort in the center located in the alley. It's an easy and simple way for you to contribute to the health of your community and city. In the evening, lights strung up in the alley come on, people sit outside sipping wine and after dinner coffee. Others stroll up and down, exploring small jewellery and second hand stores that have popped up along the spaces lining the alley. Flowers scent the air and small children learn to ride their bikes away from the danger of cars on the streets.

The alley has become a gathering spot for the block and the neighborhood. Lovingly tended by the community, it offers opportunities beyond what the tenants originally imagined.

Steps towards Alley Improvement

1. Talk to your neighbors.
2. Clean up your alley.
3. Evaluate if there are major failures or dangers in the alley.
4. Determine the easy changes, like adding potted plants and chairs, versus long term plans, such as redoing pavement.
5. Find out if your alley is in a historical neighborhood.
6. Make plans, and divide tasks. If necessary, speak to an architect, landscape architect, or engineer.
7. Talk to city, obtain necessary permits.
8. Make your alley changes for a better Seattle!

Alley activism can change the way we engage with our city.



Special thanks to...

Nancy Rottle, University of Washington Green Futures Lab.
Mary Delorme and Mark Schleck, ScanDesign Foundation.
Jan Gehl, Helle Søholt, Jeff Risom, Gehl Architects.

Gary Johnson, Seattle Department of Planning and Development.
April Mills, Seattle Public Utilities.
Barbara Gray, Seattle Department of Transportation
Todd Vogel and Nikki Somers, International Sustainability Institute.

And the many more that are working on improving urban alleys.

photo credits
Nancy Rottle, International Sustainability Institute, Jennifer Hampton, Mary Fialko

GREEN FUTURES RESEARCH
& DESIGN LAB
University of Washington College of Built Environments
242 Gould Hall Box 355734 | Seattle, WA 98195 | www.greenfutures.washington.edu

GEHL ARCHITECTS
URBAN QUALITY CONSULTANTS

scan | design
foundation
BY INGER & JENS BRUUN

Appendix

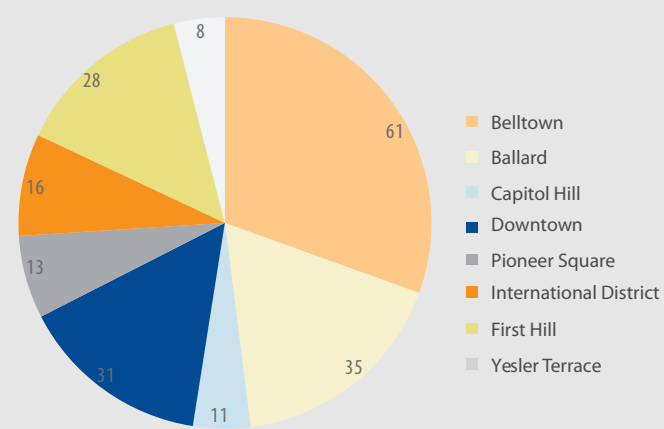

Alleys researched in each selected neighborhood

In the summer of 2010, we collected data on 200 alleys in Seattle. Through observation and analysis, we have data on alley use, qualities and surroundings. In the following appendix, we will present data for alleys at the city scale, taking an average of the data collected for each neighborhood. Additionally, the references and resources that we used in developing the Integrated Alley Handbook can be found at the end of this document.

Alley in Christchurch, New Zealand

Data for alleys in the City of Seattle

In the summer of 2010, data was collected for 195 alleys in Seattle. Included were the neighborhoods of Pioneer Square, International District, Yesler Terrace, Downtown, Belltown, Capitol Hill, and Ballard. The information collected ranges from smells and sounds, plant and animal life, the built environment, services, auto uses, and pedestrian uses. The following data represents a cumulation of the results for all neighborhoods in the selected study group.

All data was collected by Jennifer Hampton and Mary Fialko between the hours of 9am and 6pm on weekdays.

Steepness of slope

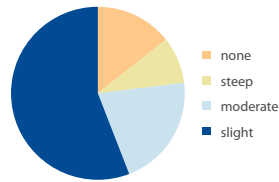

Existence of canopies

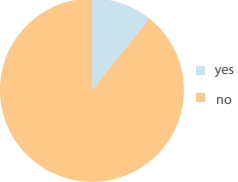

Alley width

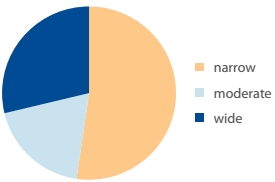

Existence of smells

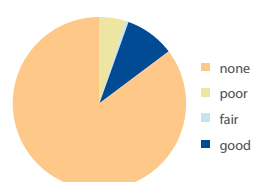

Primary alley use

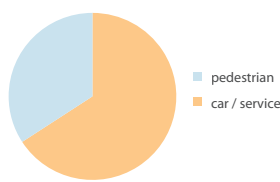

Existence of graphics

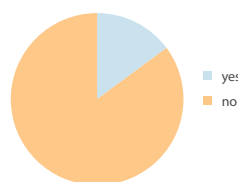

Nearby existing public space

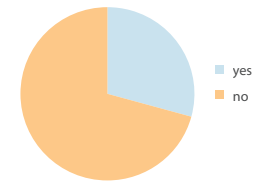

Existence of drains

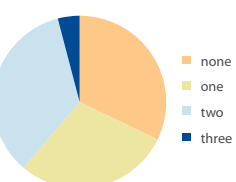

Existence of furniture

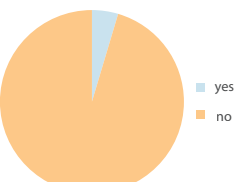

Number of doors

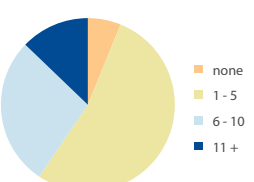

Existence of eyes on the alley

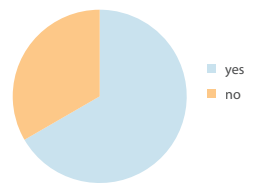

Feeling of Safety

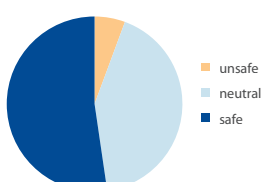

Existence of animal life

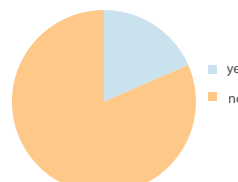

Nearby existing public transit

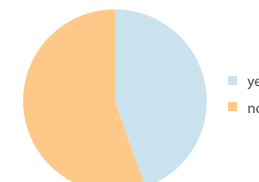

Paving types

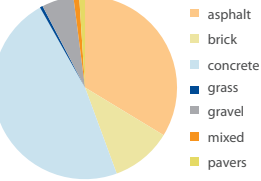

Existence of trash containers

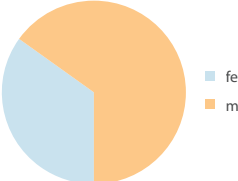

Number of garage doors

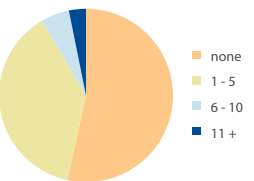

Walking conditions

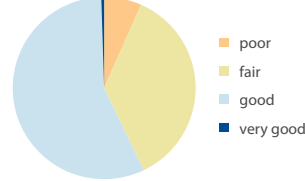

Existence of sounds

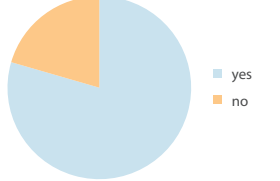

Existence of plant life

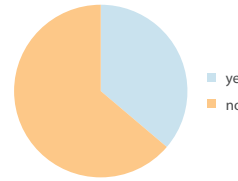

Facade quality

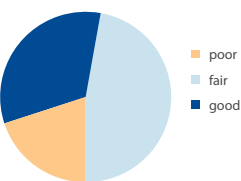

Existence of service parking

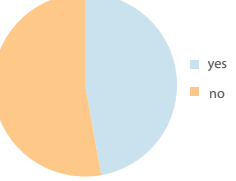

Adjacent buildings maintained

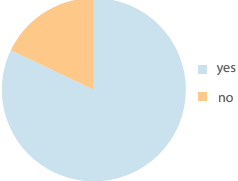

Number of windows

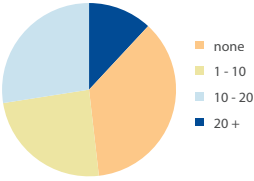

Existence of desire lines

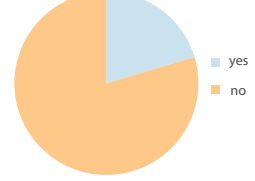

Invitation for interaction

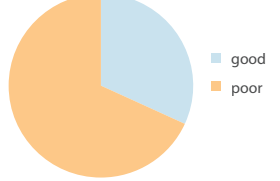

Existence of trees

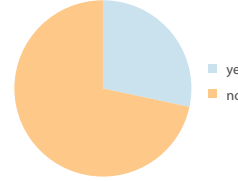

Adjacent building use

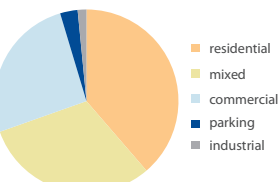

Building heights

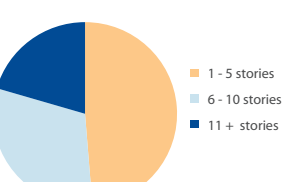

Adjacent building materials

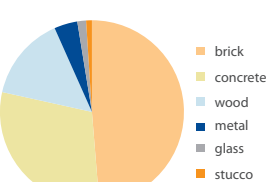

Existence of businesses

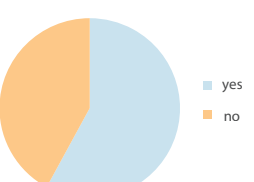

Pedestrians on the adjacent streets

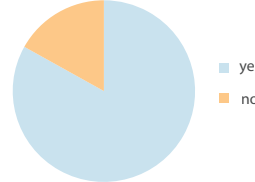

Existence of positive evening activities

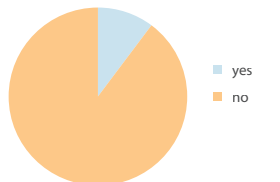

Bike Friendly

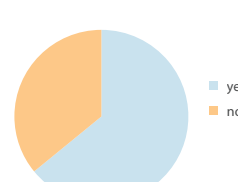

Alley Neighborhood Information

The following data represents a breakdown of alley locations and highlighted information for each of the selected neighborhoods studied. For each alley, data was collected about the alley use, conditions, and connections along with photos taken at each end.

Neighborhoods change dramatically across Seattle, each with its own central identity. Alley updates in each neighborhood should enhance the existing identity of the neighborhood and its residents to strengthen the existing community. We have broken down research from the neighborhoods surveyed to point out keys that could serve as starting points for each neighborhood.



Belltown

- 98% of alleys are currently paved in asphalt or concrete- impervious surfaces.
- Many pedestrians around most alleys- possibility of a strong pedestrian alley network
- Only 20% have planned plant life- this is a key strategy
- Only 35% of alleys feel safe- safety should be a focus in Belltown.
- 90% have adjacent businesses
- 20% have graphics- higher than any other Neighborhood.

Potential:
Connections and additional real estate in a busy retail and restaurant district.



Capitol Hill

- All have good walking conditions
- Low building heights- 5 stories max.
- None are used by the community!
- 90% have eyes on the street- making the alleys very safe!

Potential:
Low-key community spaces.



Ballard

- All buildings are low height at 1-3 stories.
- 90% of alleys are residential
- 95% have unplanned plant life, showing good growing conditions
- 85% have trees- higher than any other neighborhood
- High safety rating
- High human scale rating

Potential:
Important rainwater treatment and family friendly spaces.

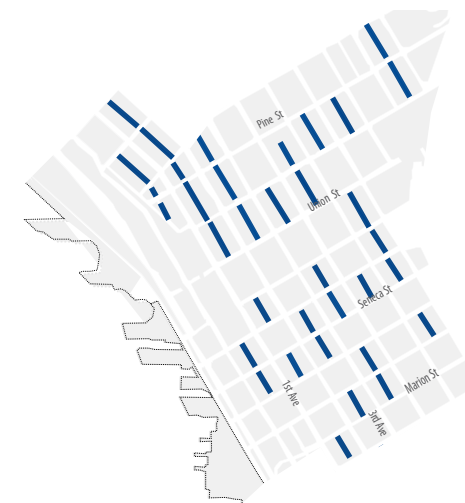

Downtown

- Wide variety of paving types, could be unified for a common alley identity!
- Good walking conditions exist in 98% of alleys.
- Highest building heights- it is important to compensate for too much shade.
- All used for trash pickup and other services
- 80% already used by pedestrians
- 50% have adjacent businesses
- 70% are bike friendly.

Potential:
Alleys as a place of discovery and intrigue in a thriving downtown.

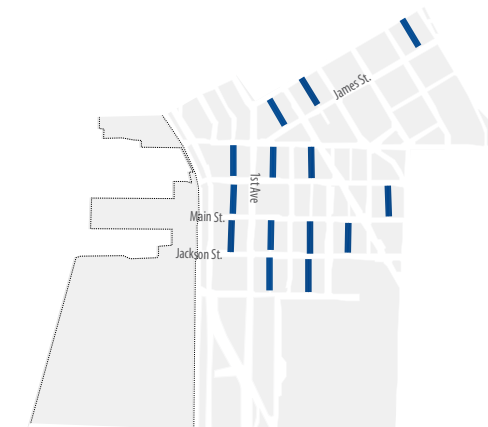

Pioneer Square

- Only 1 alley with canopy protection.
- Only one alley with places to sit.
- 98% of alleys are regularly used by pedestrians
- 90% are appealing and maintained
- 98% are brick
- 50% have businesses adjacent
- 100% already lit.
- 90% are near public space and public transportation.

Potential:
Great and safe public life alleys!





International District

- Hilliest neighborhood- 90% have moderate to steep slopes.
- All but 2 alleys have dumpsters- this neighborhood could benefit greatly from the clear alleys program.
- Only 2 alleys have trees- we should replace dumpsters with trees!
- 50% have businesses
- Only 30% have good façade quality.
- Only 3 alleys in the International District are near public transit
- 50% are bike friendly.

Potential:

Bustling mixed use district, with alleys providing important connections!



First Hill

- Very hilly neighborhood- most alleys are moderately to steeply sloped
- Most diverse alley neighborhood- there is a wide range in most criteria, including building heights, building material, and paving material.
- 90% of alleys used for trash and parking
- 85% of alleys in first Hill are bike friendly, but only 10 are near public space, and only 30% are near public transit.

Potential:

Alleys vary according to the needs of adjacent buildings and neighbors.



Yesler Terrace

- All alleys have adjacent residences.
- 70% have unplanned plant life, and 50% have planned plant life.
- No to few trees in every alley.
- All alleys are moderate to narrow
- No Businesses.
- Many windows looking out to the alleys
- No nearby public space or easy access to public transit in any alley.

Potential:

Family friendly garden alleys!



Resources and References

Urban Design and alleys

Gehl Architects 2009 Public Space and Public Life report
http://www.seattle.gov/dpd/Planning/Center_City/Projects/default.asp

International Sustainability Institute: Alley Art
<http://www.alleyart.org/>

Green Futures Lab
<http://greenfutures.washington.edu/index.php>

Seattle Alley Research blog by Daniel Toole
<http://alleysofseattle.com/>

Stormwater management and alleys

Ballard Roadside and Alley raingarden program
<https://rainwise.seattle.gov/systems/water/community/overview>

Chicago Green Alley Handbook

http://egov.cityofchicago.org/webportal/COCWebPortal/COC_EDITORIAL/GreenAlleyHandbook.pdf

Seattle alley improvements procedures

Seattle Clear alleys program
<http://seattlecap.wm.com/>

City of Seattle Alley improvement Guideline
<http://www.cityofseattle.net/transportation/alleys.htm>

Seattle alley permitting references

City of Seattle permitting
http://www.cityofseattle.net/transportation/stuse_permits.htm

Chuck Wolfe
<http://www.myurbanist.com/>

To find more information check out our blog at www.integratedalleys.tumblr.com/

GREEN FUTURES RESEARCH & DESIGN LAB
 University of Washington College of Built Environments
 242 Gould Hall Box 355734 | Seattle, WA 98195 | www.greenfutures.washington.edu

GEHL ARCHITECTS
 URBAN QUALITY CONSULTANTS

scan | design
 foundation
 BY INGER & JENS BRUUN

activate your alley!
