

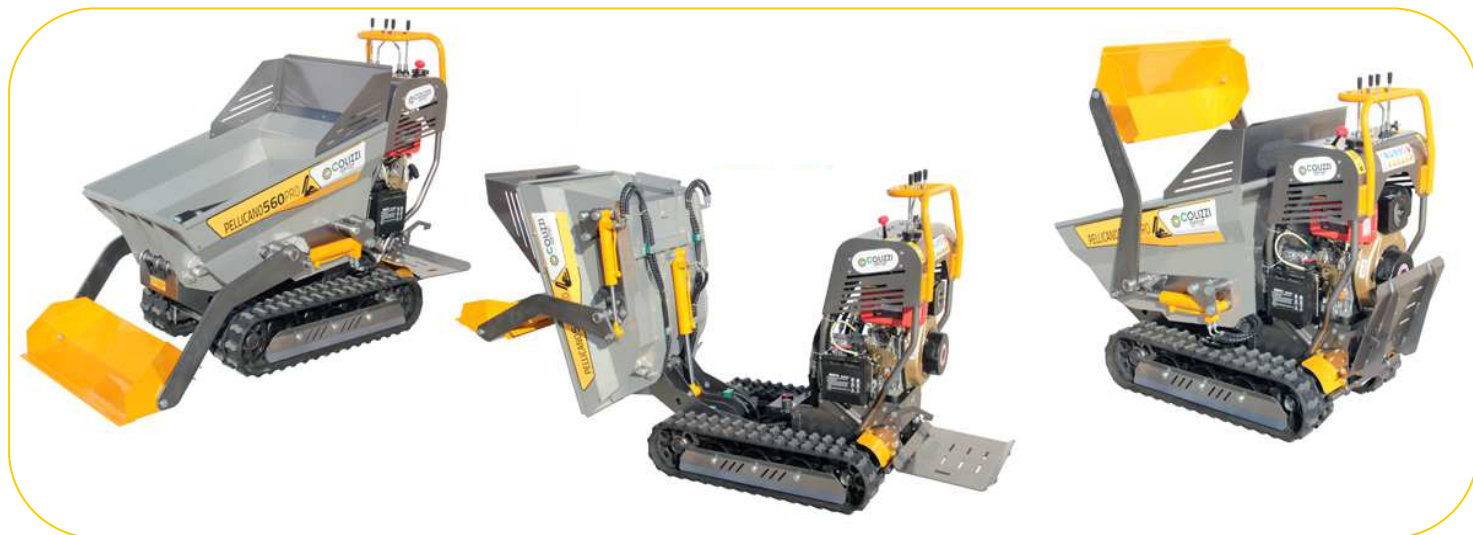

## MINI DUMPER PELLICANO 560

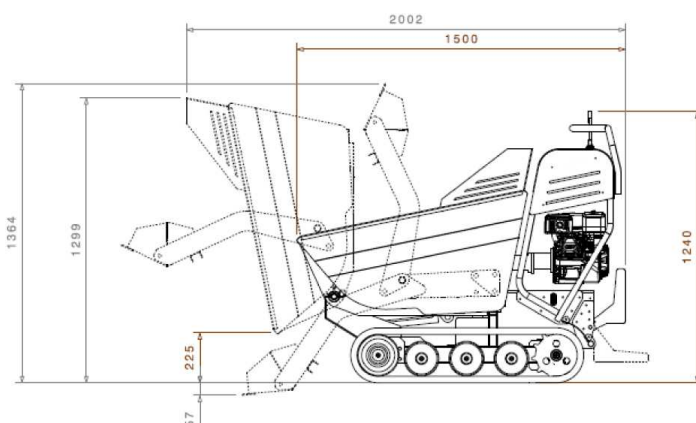

Codice	Modello	Motore	Potenza Motore	Pala	accessorio di serie	Peso a vuoto	Dimensioni
212010	PELLICANO 560 M210	M210 BENZINA	4,2 kw	NO	Radiatore raff.to olio	310	1610x720x1175
212020	PELLICANO 560 GX200	GX200 HONDA	4,1 kw		Radiatore raff.to olio	320	
212030	PELLICANO 560 DIESEL	KM178 DIESEL	4,0 kw			350	
212040	PELLICANO 560 PRO M210	M210 BENZINA	4,2 kw	SI	Radiatore raff.to olio	395	1890x835x1175
212050	PELLICANO 560 PRO GX200	GX200 HONDA	4,1 kw		Radiatore raff.to olio	405	
212060	PELLICANO 560 PRO DIESEL	KM178 DIESEL	4,0 kw			435	
212070	PELLICANO 560 PRO M210 i	M210 BENZINA	4,2 kw		Generatore 3KwA incorporato	420	

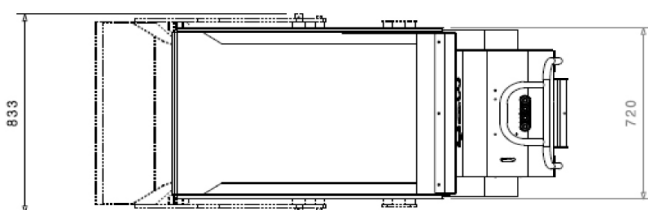

## MINI DUMPER PELLICANO 560



Portata Dumper	Pendenza max	Trasmissione	Pompa	Motori
500 Kg in piano 350 Kg in pendenza 0,20 metri cubi	30°	Idrostatica	N°2 pompe ad ingranaggi portata 15lt/min	Motori orbitali OMS 200 cc rinforzati



Freno	Sterzata	Ribaltamento	Piano di carico	Cingolo
Valvola di blocco idraulica automatica	Idraulica	Idraulica	Dumper Edile	con 3 rulli per lato dimensioni 160x60x37mm e tensione registrabile