

The Golden Symbol & Facts

By

Thiyagarajan.S
(Σηοονψα)

April - 2006

Acknowledgements

I would like to thank my friends Mr.Aravind, Mr. Tony, Mr. Stalin and Mr. Praveen who gave me immense moral support. Mr. Ram Mohan has been more of a friend than a supervisor during the course of my studies and invaluable as a sounding board for ideas and approaches.

Once again I would like to thank my friends for their numerous stimulating conversations and insights into my work. A special word of thanks to Mr. Ram Mohan for the many valued discussions related to this work.

I would like to thank my family, especially my Parents, for the opportunities they have provided us with and for teaching us all that our abilities are limited only by our imagination. For pushing us, understanding us, and helping us achieve our dreams.

I would like to thank Mr. Gary Meisner who has allowed me to submit my thesis for this contest, because he relaxed the rules of the PHI contest for my successful entry.

Lastly I would like to thank the Almighty; I could not have done without him.

Table of contents

1. Introduction	4
2. The Golden Symbol (TGS).....	5
3. Fibonacci Series.....	6
4. Facts about the Golden Symbol.....	7
5. The Virtual Holy cross.....	10
6. Pentagram.....	10
7. PI and PHI.....	11
8. The Vitruvian Man.....	11
9. Primary and Secondary Colors (RGB).....	12
10. Basic Shapes.....	13
11. Symbols.....	15
12. Future work.....	16
13. Summary.....	17

Introduction

The Golden Symbol has developed to represent the divine proportion of each an every element of nature. It just deals with how nature, Architecture, Shapes, Colors, Balance, Art, Flowers, weapons, ques and science, especially aerodynamics has its own special relationship with the Golden Number.

To represent all possible combinations of Golden ratio, TGS has all types of shapes, pentagram, flowers, numbers, symbols, constants, RGB, weapons, leaves and quarter circles.

Though PHI has the Biblical touch, TGS is the first step of our project to examine the ancient Indian Culture, to understand if they were aware of the Golden ratio or used the divine proportion in Architecture, Art, Temples, Pools, Weapons, Dance moves and Music unknowingly.

Through deep discussions and valuable studies, we came to the conclusion that Ancient Indian heroes used symbols to represent their superiority. It made us think and start examining the symbols used by the Kings and gods in ancient stories and kavyas.

The Golden Symbol (TGS)

The Golden Symbol has visual and hidden elements to represent the Fibonacci series, PHI, PI, Vitruvian Man, Basic Shapes, Pentagram and the virtual holy Cross.



The Golden Symbol has been designed as per the Golden ratio. It has many hidden and visual PHI relationships with Art, colors, Shapes, spirals, Holy cross, PI, Symbols, visible and Invisible Symbols.

TGS has been developed for the sole reason of participating in the PHI contest which is being conducted by PHI Organization. It has numerous combinations of PHI Relationships in it.

Fibonacci Series

Fibonacci Series starts with 0 and 1, and then produces the next Fibonacci number by adding the two previous Fibonacci numbers. The first Fibonacci numbers for $n = 0, 1$

The F.Series = 0, 1, 1, 2, 3, 5, 8, 13, 21, 34, 55, 89, 144, 233, 377, 610, 987, 1597, 2584, 4181, 6765, 10946

$$F_n := F(n) := \begin{cases} 0 & \text{if } n = 0; \\ 1 & \text{if } n = 1; \\ F(n - 1) + F(n - 2) & \text{if } n > 1. \end{cases}$$

Pic (i)

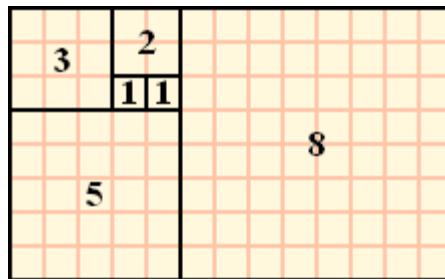

Pic (ii)

Pictures courtesy: www.wikipedia.com

- PI Symbol – 1
- A Golden Rod – 1
- Stars – 2
- Red Bullets in Centre Space – 3
- Green Bullets in a Golden Rod – 5
- Total Red Pieces in Four Quarter Circles – 8
- Total No. of Visible Letters representing PHI in numbers, Symbols and Alphabets. – 13 (Inclusive of Decimal Characters)

Facts about the Golden Symbol

The Golden Rod

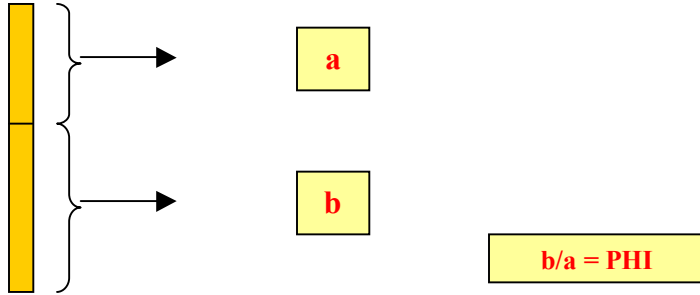

The Distance between the centre point and the top of the golden rod = a

The Distance between the centre point and the bottom of the golden rod = b

Left top Quarter Circle Numbers

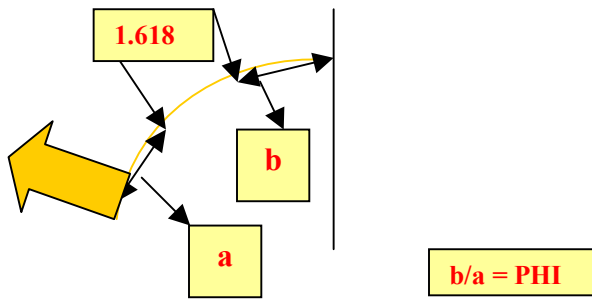

The Distance between the Left top arrow and 1.618 = a

The Distance between 1.618 and the Golden rod Head = b

Left Top Quarter Circle

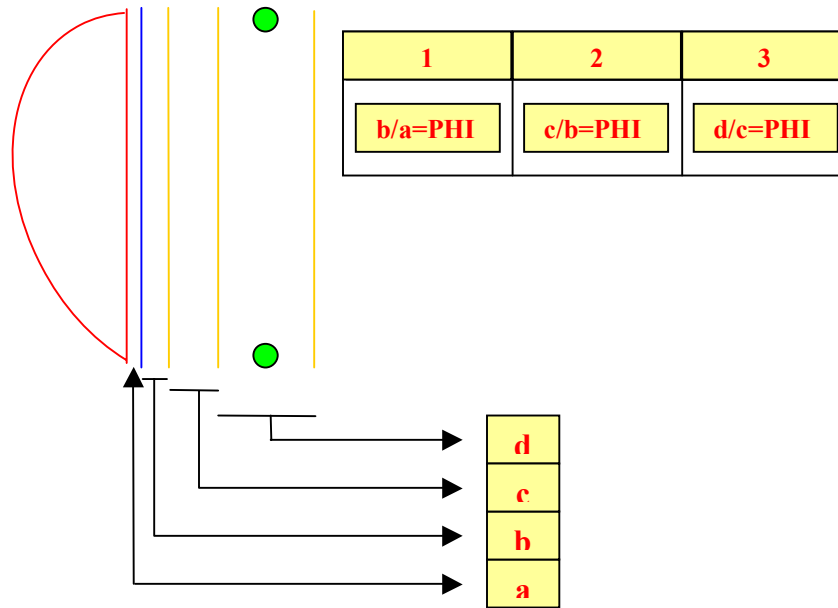

Spear and Inner Leaf

Left Top Quarter circle and outer Ring.

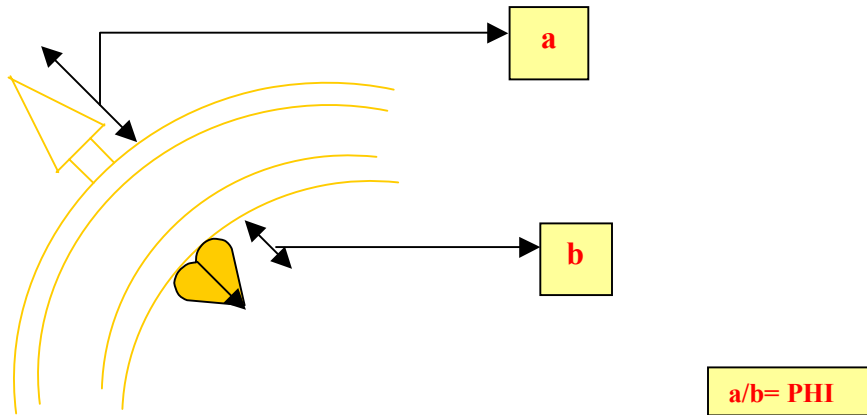

The Distance from the Outer ring to the Spike tip (Height) -a

The inner circle's Leaf height.-b

$$a / b = \text{PHI}$$

Spiral

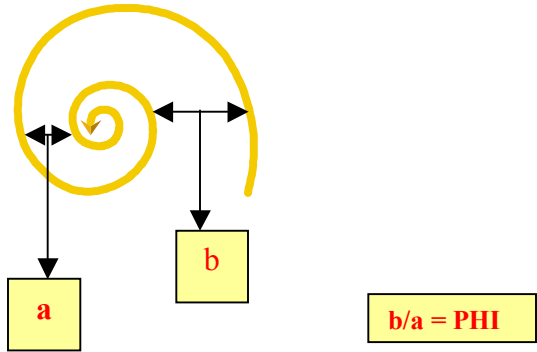

Ref:

Our earlier Calculations prove that the ‘Spiral’ is naturally designed as per “The Golden Ratio”

Distance between Two Spirals

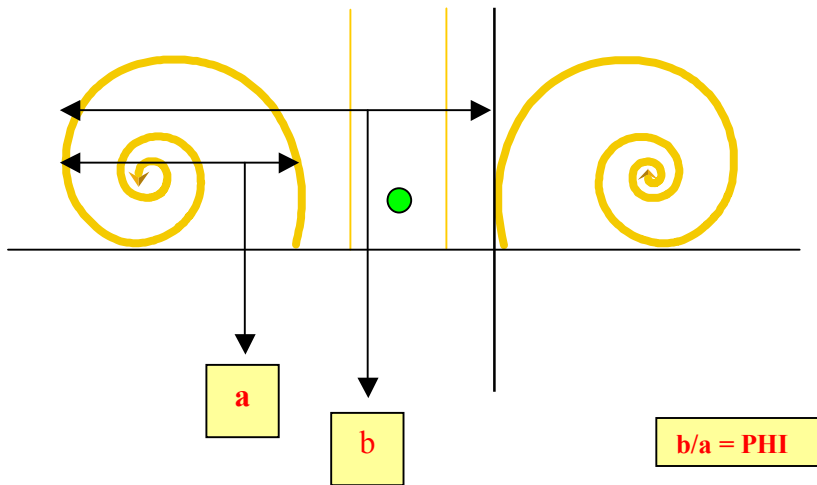

The Distance between the two has been spirals provided as per the golden ratio.
 i.e. After 1.618 times of the spiral length another spiral will be placed.

Virtual Shape of the Holy Cross

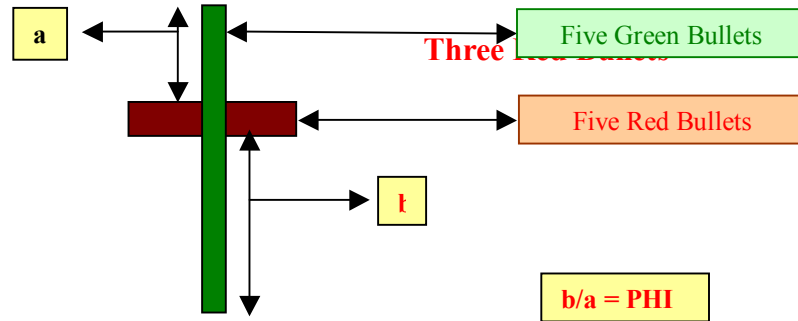

The holy cross made as per the Golden ratio.

The Pentagram

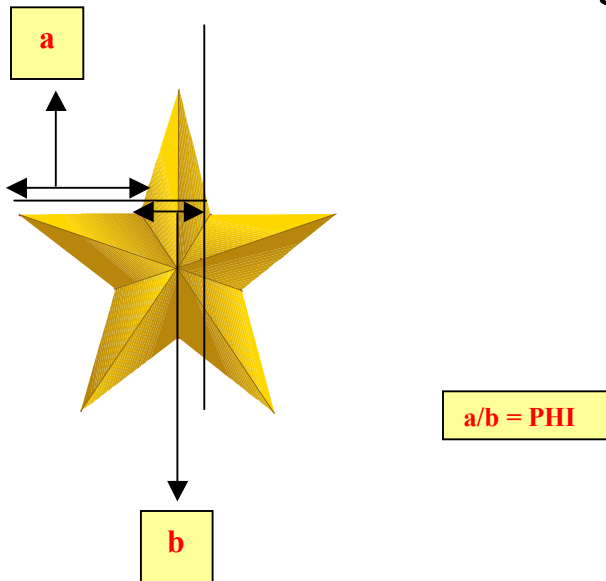

A pentagram has many segment relationships with the golden ratio.

The PI and PHI



Though pi has the perfect and proved value of 3.1416, it has many approximations given by mathematicians from various countries.

According to the last mathematician, the greater approximation is 3.2, which can be obtained by dividing 13 by 4.

Square of PHI (ϕ^2) gives the greater approximation of PI.

On the other side PI (π) divided by 2 gives the approximation of PHI which is 1.6.

The Vitruvian Man and the Golden Ratio

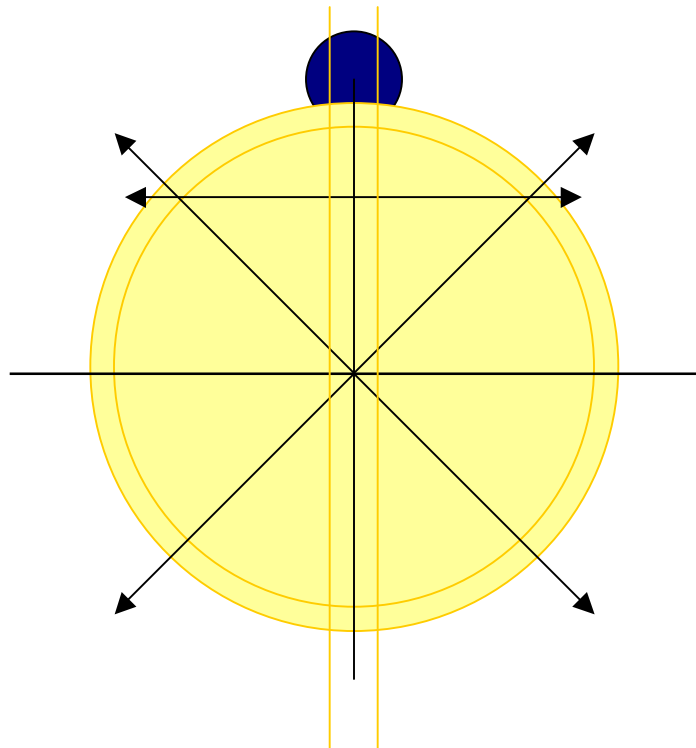

Skeleton diagram of the Golden Symbol

The Above mentioned diagram is the representation of the vitruvian man, which has already been proven as the divine proportion by Honr.Leanardo Da Vinci.

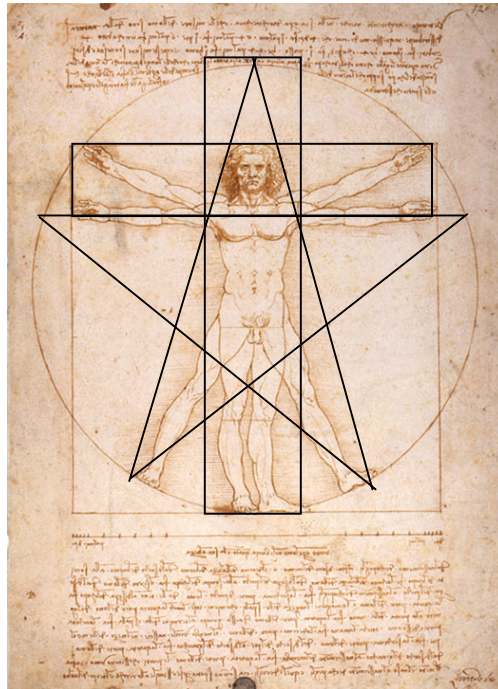

The virtuvian man by Hon.Leanardo Da Vinci

RGB and the Golden Ratio

Red, Green, Blue Bullets representing the Golden relationship COLORS and the PHI.



The prime colors and the derived colors have a relationship with PHI. The Primary and secondary colors have the Golden ratio between them.

Shapes

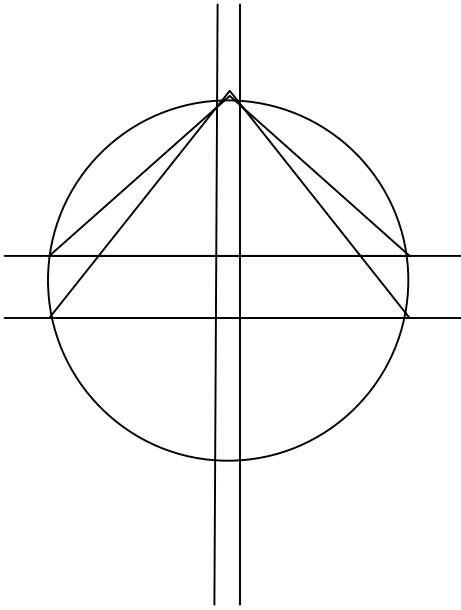

Triangles

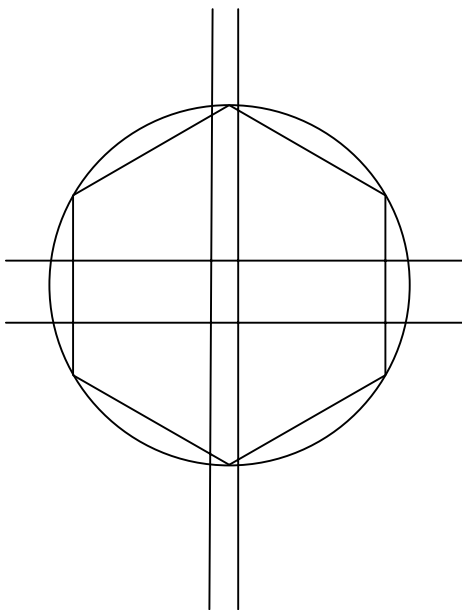

Hexagon



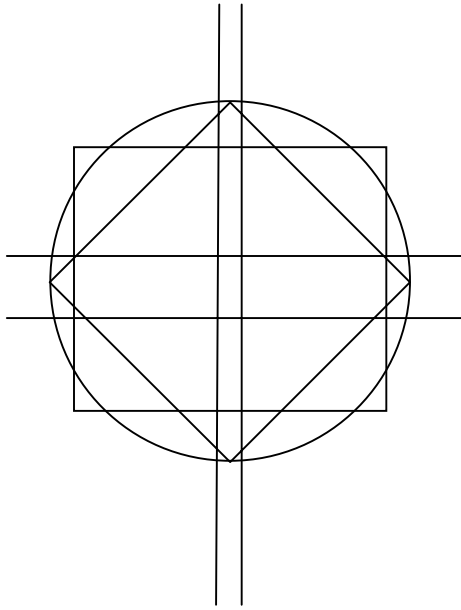

Circle and Square

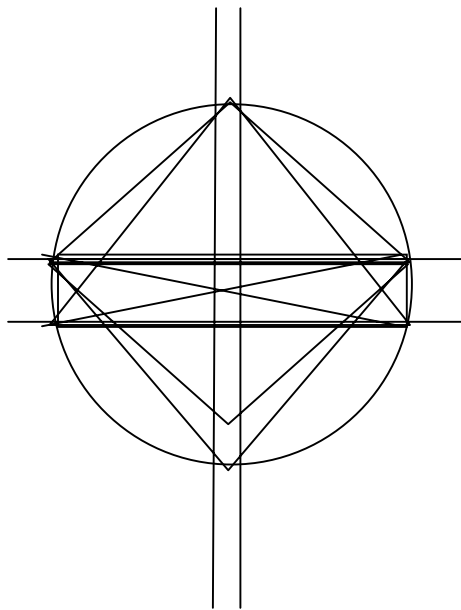

Polygon

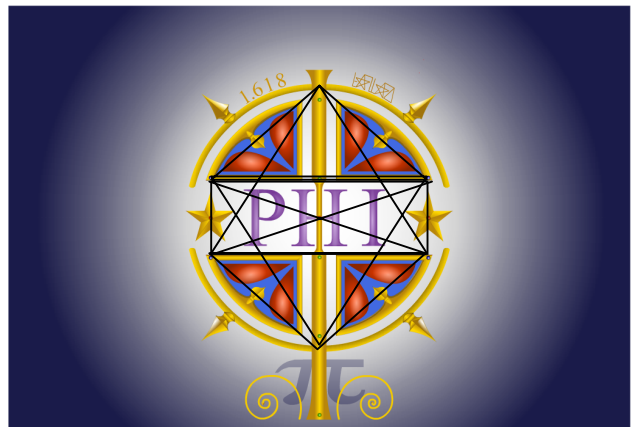





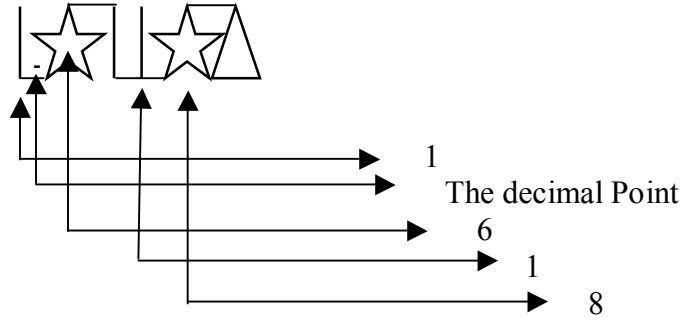

The Symbols

The symbols on the outer circle representing the PHI value. It shows the PHI influence in the Shapes.



Decimal Number	Symbolic Number System(SMS)
1	
2	∟
3	△
4	□
5	☆
6	☆∟

7	
8	
9	
0	
.	-
	Addition
	Conjunction

Future Work

- i)** Existence of PHI in Ancient India. (Examining PHI relationship in Religious Symbols, Sculptures, rituals and Instructions)
- ii)** The Golden Point. (The Balancing point of an object resides where? why? Research based on Energy neutralization theory.)
- iii)** Fibonacci Series: - Where it was originated really? (Examining the root of mathematics)
- iv)** Are we playing a right game with right rules? (Examining the Evolution theory)
- v)** The Theory of 0 to 100. (Where we start? and where we end up with?)

Summary

In this thesis I have provided possible implications of PHI presence in various elements and objects involved in day to day activities like mathematic expressions, symbols, colors, shapes, flowers, weapons, art and architecture.

The Golden Symbol just reciprocates the PHI (Φ) symbol and has its own elements to prove the Magic calibration in nature. I have segregated all the elements one by one and given the study oriented relationships with PHI. I have submitted part of my studies and explanations to bring up the concept unambiguously.

I hope this symbol gives more information about PHI, for beginners and readers. This conceptual submission has made us dig more of the Indian soil for PHI existence.

Though I have given part of my study details, I hope this will meet the contest rules and regulations. I haven't stopped my process to prove the divine proportion in all sorts of existence.

For this submission I have created my own number system which communicates the PHI in every possible combination.