



TEENAGE MUTANT NINJA

TURTLES®

4 PLAYER UPRIGHT INSTRUCTION MANUAL

TEENAGE MUTANT NINJA TURTLES
® © Mirage Studios, USA.

All rights reserved. Trademark use granted to Konami under license from Mirage Studios, USA.
Exclusively licensed by Surge Licensing, Inc.

© Konami Inc. 1989

 **KONAMI**® is a trademark of Konami Industry Co., Ltd.

Part Number 963400

T.M.N.T.: PARTS LIST

Part #	Description
30110	Red Button
30112	Blue Button
30118	Yellow Button
30260	Violet Button
30202	Switch Holders
30250	Palnuts
30304	Red Joy Stick
30305	Blue Joy Stick
30307	Yellow Joy Stick
30321	Violet Joy Stick
30502	Control Panel Hinge
35101	Fuse 1 AMP
35104	Fuse 4 AMP
35105	Fuse 5 AMP
35201	ISO Transformer
35300	Line Filter
35403	Power Supply
40101	Coin Door W/Meter
40106	Coin Door No/Meter
40208	Marquee Bracket (Acute)
40209	Marquee Bracket (Obtuse)
40355	Marquee Plexi
40356	Tempered Glass
40505	25 Inch Monitor
40611	Bezel 25"
40700	Light Fixture
40702	Light Bulb
40946	A.C. Harness
963003	T.M.N.T. P.C.B.
963011	T.M.N.T. DC Harness
963100	T.M.N.T. CPO
963101	T.M.N.T. Instruction Decal
963200	T.M.N.T. Marquee
963304	T.M.N.T. Right Logo Side Decal
963305	T.M.N.T. Left Logo Side Decal
963306	T.M.N.T. Middle Right Side Decal
963307	T.M.N.T. Middle Left Side Decal
963308	T.M.N.T. Lower Right Side Decal
963309	T.M.N.T. Lower Left Side Decal
963400	T.M.N.T. Manual (4P)

T.M.N.T.: AC FLOW CHART

1. GREEN/YELLOW
2. BLACK
3. RED
4. BLUE
5. BROWN
6. RED/BLACK
7. BLACK/WHITE
8. WHITE
9. GREEN
10. VIOLET
11. ORANGE

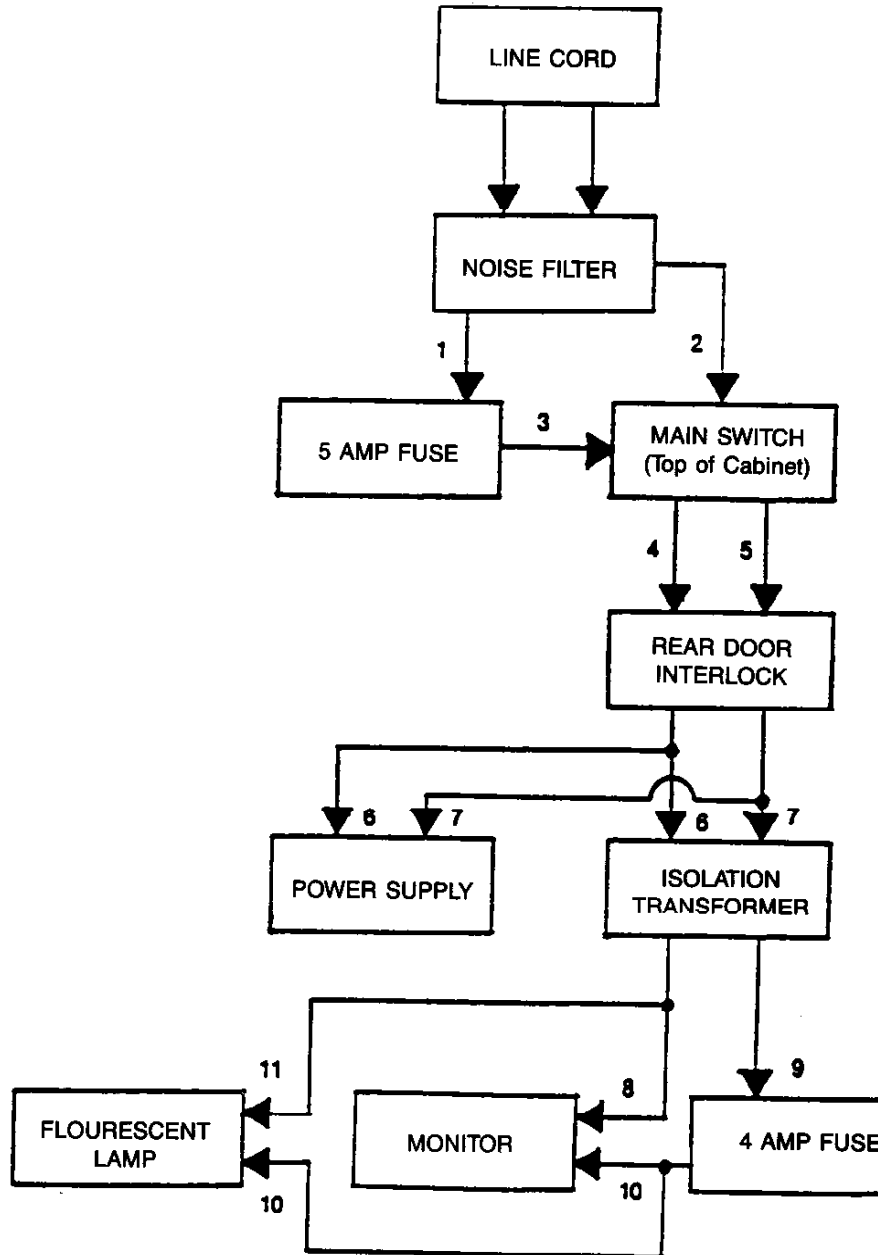

T.M.N.T.: WIRING HARNESS

WIRE COLOR KEY:		← Solder Side	Parts Side →		
BLACK	GND	A	1	GND	BLACK
BLACK	GND	B	2	GND	BLACK
RED	+5V DC	C	3	+5V DC	RED
RED	+5V DC	D	4	+5V DC	RED
	NOT USED	E	5	NOT USED	
ORANGE	+12V DC	F	6	+12V DC	ORANGE
	*KEY	H	7	*KEY	
	(EMPTY)	J	8	COIN COUNTER	GREEN/GRAY
	(EMPTY)	K	9	(EMPTY)	
YELLOW	SPEAKER (-)	L	10	SPEAKER (+)	BLUE
	(EMPTY)	M	11	(EMPTY)	
WHITE/GREEN	VIDEO GREEN	N	12	VIDEO RED	RED/WHITE
WHITE	VIDEO SYNC	P	13	VIDEO BLUE	BLUE/WHITE
	(EMPTY)	R	14	VIDEO GROUND	BLACK
	(EMPTY)	S	15	(EMPTY)	
VIOLET/WHITE	COIN 2	T	16	COIN 1	BLUE/BROWN
	NOT USED	U	17	NOT USED	
BLUE/YELLOW	2P UP	V	18	1P UP	ORANGE/WHITE
VIOLET/YELLOW	2P DOWN	W	19	1P DOWN	BLACK/WHITE
ORANGE/GREEN	2P LEFT	X	20	1P LEFT	RED/GRAY
ORANGE/YELLOW	2P RIGHT	Y	21	1P RIGHT	GRAY/WHITE
BLACK/YELLOW	<i>A</i> 2P JUMP	Z	22	1P JUMP <i>A</i>	RED/WHITE
ORANGE/GRAY	<i>B</i> 2P ATTACK	a	23	1P ATTACK <i>B</i>	GREEN/BROWN
	NOT USED	b	24	NOT USED	
	NOT USED	c	25	NOT USED	
	NOT USED	d	26	NOT USED	
BLACK	GND	e	27	GND	BLACK
BLACK	GND	f	28	GND	BLACK

(BASE COLOR/LINE COLOR)

T.M.N.T.: SUB HARNESS FOR 3 PLAYERS & 4 PLAYERS

CN3 3P CONTROLS	1	Coin 3	White/Violet
	2	Empty	
	3	3P Left	White/Red
	4	3P Right	White/Yellow
	5	3P Up	White/Black
	6	3P Down	White/Blue
	7	3P Jump	White/Brown
	8	3P Attack	White/Orange
	9	Empty	
	10	Empty	
	11	Empty	
	12	Empty	
	13	Empty	
	14	Empty	
	15	Ground	Black

CN4 4P CONTROLS	1	Coin 4	Blue
	2	Empty	
	3	4P Left	Yellow/Black
	4	4P Right	Brown/Black
	5	4P Up	Green/Yellow
	6	4P Down	Yellow/Red
	7	4P Jump	Yellow/White
	8	4P Attack	Yellow/Blue
	9	Empty	
	10	Empty	
	11	Empty	
	12	Empty	
	13	Empty	
	14	Empty	
	15	Ground	Black

4P VERSION WIRING DIAGRAM

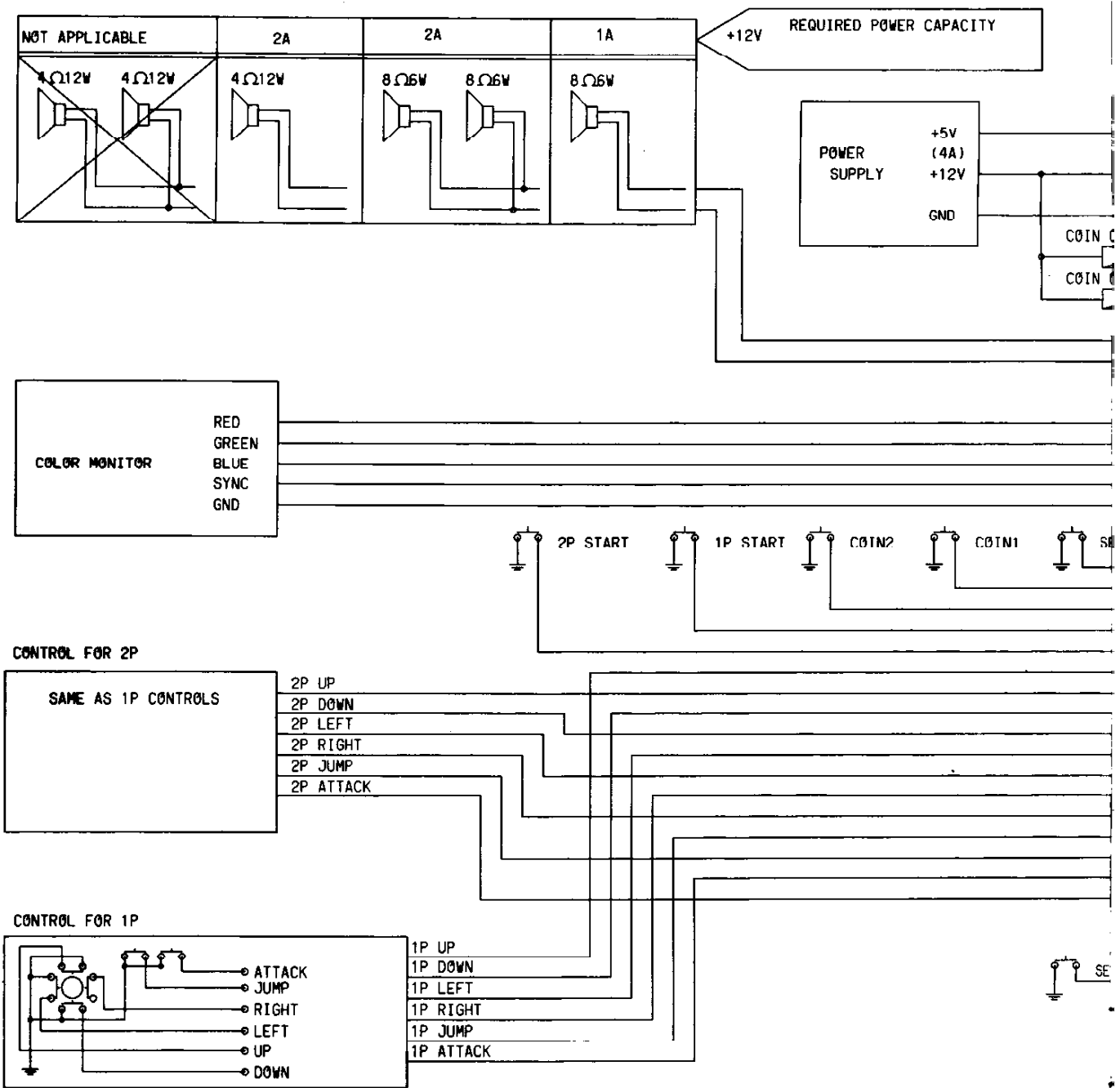

- NOTES -
- 1P:NO.1 PLAYER 2P:NO.2 PLAYER
3P:NO.3 PLAYER 4P:NO.4 PLAYER
 - 2 SURGE KILLER DIODES FOR COIN COUNTER INSTALLED ON THE P.C.B.*

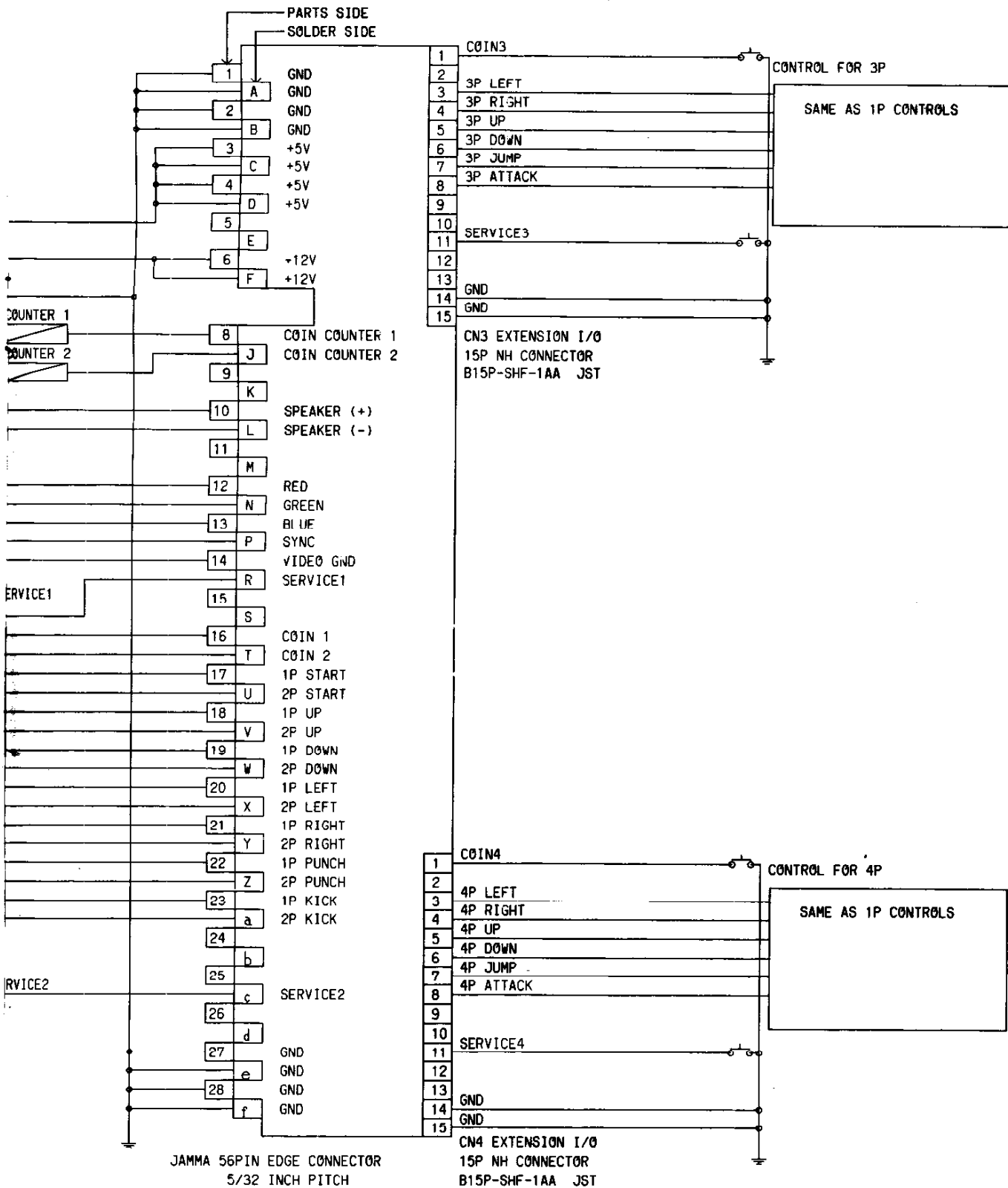

T.M.N.T. DIP SWITCH SETTINGS

DIP SWITCH NO. 1 SETTINGS

1. COIN SWITCH NO. 1 SETTINGS

SW	1	2	3	4	COIN	PLAY
○	OFF	OFF	OFF	OFF	1	1
	ON				1	2
	OFF	ON			1	3
	ON				1	4
	OFF	OFF	ON	OFF	1	5
	ON				1	6
	OFF	ON			1	7
	ON				2	1
	OFF	OFF	OFF	ON	2	3
	ON				2	5
	OFF	ON			3	1
	ON				3	2
	OFF	OFF	ON	ON	3	4
	ON				4	1
	OFF	ON			4	3
	ON				5	1

SW5 thru SW8 are not used.

DIP SWITCH NO. 2 SETTINGS

1. THE NUMBER OF PLAYER'S LIFE

SW	1	2	NUMBER
○	OFF	OFF	1
	ON		2
	OFF	ON	3
	ON		5

2. DIFFICULTY OF THE GAME

SW	6	7	DIFFICULTY
○	OFF	OFF	EASY
	ON		NORMAL
	OFF	ON	DIFFICULT
	ON		VERY DIFFICULT

3. SOUND IN ATTRACTIVE MODE

SW	8	SOUND
○	OFF	OFF
	ON	ON

SW3 thru SW5 are not used.

DIP SWITCH NO. 3 SETTINGS

1. VIDEO SCREEN FLIP

SW	1	
○	OFF	NORMAL
	ON	UPSIDE DOWN

2. CHANGE OF MODE

SW	3	MODE
○	OFF	GAME MODE
	ON	TEST MODE

SW2 and SW4 are not used and should be kept OFF.

○ shows recommended settings.

Gold Mech Engineering Data and Parts List

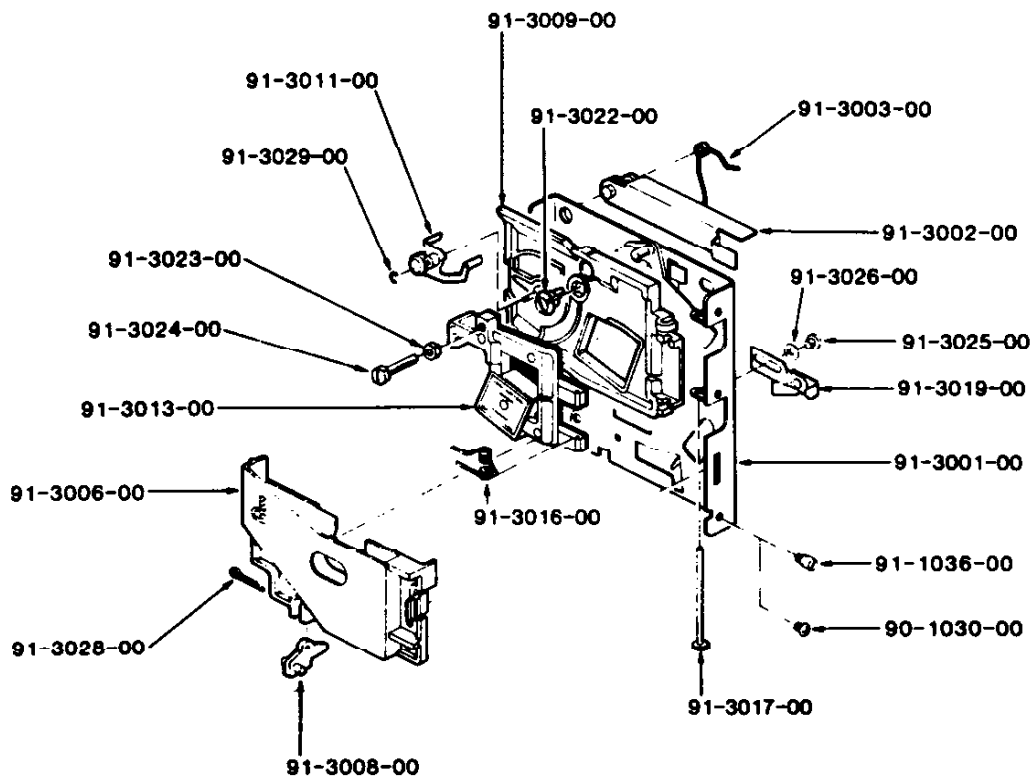

PARTS LIST

90-1030-00 Retaining Screw (#6-32"x.250")	91-3009-00 Gate	91-3023-00 Locknut-Magnet Holder
91-1036-00 Mounting Stud	91-3011-00 Cradle	91-3024-00 Screw-Magnet Holder
91-3001-00 Back Plate	91-3013-00 Magnet Holder with Magnet	91-3025-00 Screw Separator
91-3002-00 Reject Lever	91-3016-00 Gate Spring	91-3026-00 Washer
91-3003-00 Reject Lever Spring	91-3017-00 Gate Pin	91-3028-00 Cotter Pin for Anti-stringing Device
91-3006-00 Cover Plate	91-3019-00 Separator	91-3029-00 E-Clip for Cradle
91-3008-00 Anti-Stringing Device	91-3022-00 Diameter Adjustment	

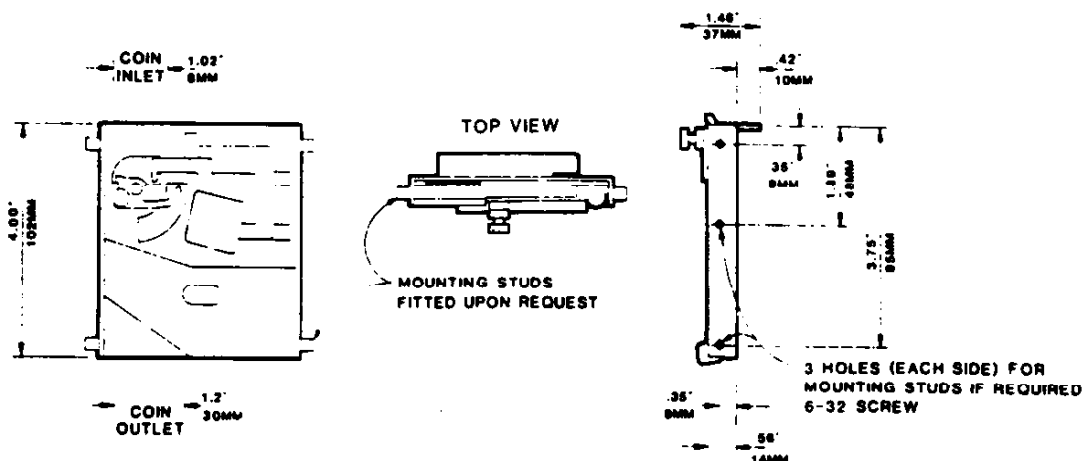

COMPLETE COIN DOOR ASSEMBLY EXPLODED VIEW

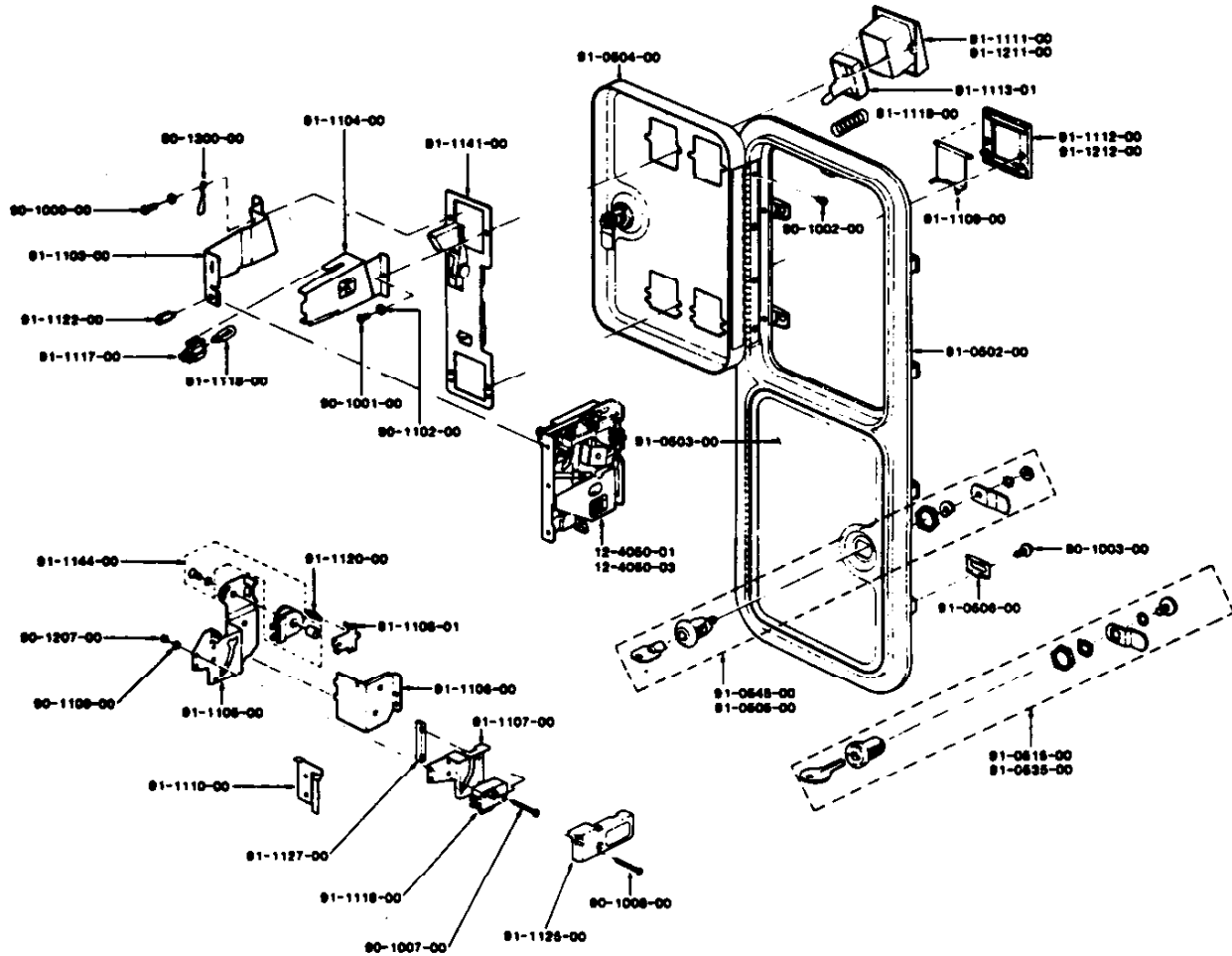

PARTS LIST

12-4050-01	S-10 Acceptor Body U.S. 25¢	90-1102-00	Washer for Bezel Screw	91-1103-00	Coin Inlet Lamp Side	91-1119-00	Button Spring
12-4050-03	S-10 Acceptor Body Canadian 25¢	90-1207-00	Nut for Microswitch Mounting Screw	91-1104-00	Coin Inlet Cover Side	91-1120-00	Lockout Spring
20-4177-00	Plastic Cash Box	90-1300-00	Keyhook	91-1105-00	Reject Cup Side Plate	91-1122-00	Retaining Screw for Acceptor Body
20-4179-00	Steel Enclosure	91-0502-00	Zinc Die Cast Frame	91-1106-00	Reject Cup Base Plate	91-1125-00	Clear Plastic Cover for Microswitch
22-1400-00	Locking Bar	91-0503-00	Lower Door	91-1107-00	Microswitch Bracket	91-1127-00	Plastic Switch Adjuster
24-1150-00	Wire Harness	91-0504-00	Upper Door	91-1108-01	Lockout Flap U.S. 25¢	91-1141-00	Base Plate With Pivot and Stud
90-1000-00	Keyhook Bezel Screw	91-0505-00	Round Lock and Cam Assembly	91-1109-00	Reject Flap	91-1144-00	6 Volt DC Lockout Coil Assembly
90-1001-00	Bezel Screw	91-0506-00	Clamp	91-1110-00	Metal Switch Adjuster	91-1211-00	Zinc Plated Button Bezel
90-1002-00	Hinge Screw	91-0515-00	Flat Lock and Cam Assembly	91-1111-00	Black Button Bezel	91-1212-00	Zinc Plated Reject Bezel
90-1003-00	Clamp Screw	91-0535-00	Flat Lock and Cam Assembly	91-1112-00	Black Reject Bezel		
90-1007-00	Flat Head Microswitch Mounting Screw	91-0545-00	Round Lock and Cam Assembly	91-1113-01	Entry/Reject Button U.S. 25¢		
90-1008-00	Panhead Microswitch Mounting Screw			91-1116-00	Microswitch (Black End Arm)		
				91-1117-00	Lampholder		
				91-1118-00	6 V Wedge Base Lamp		

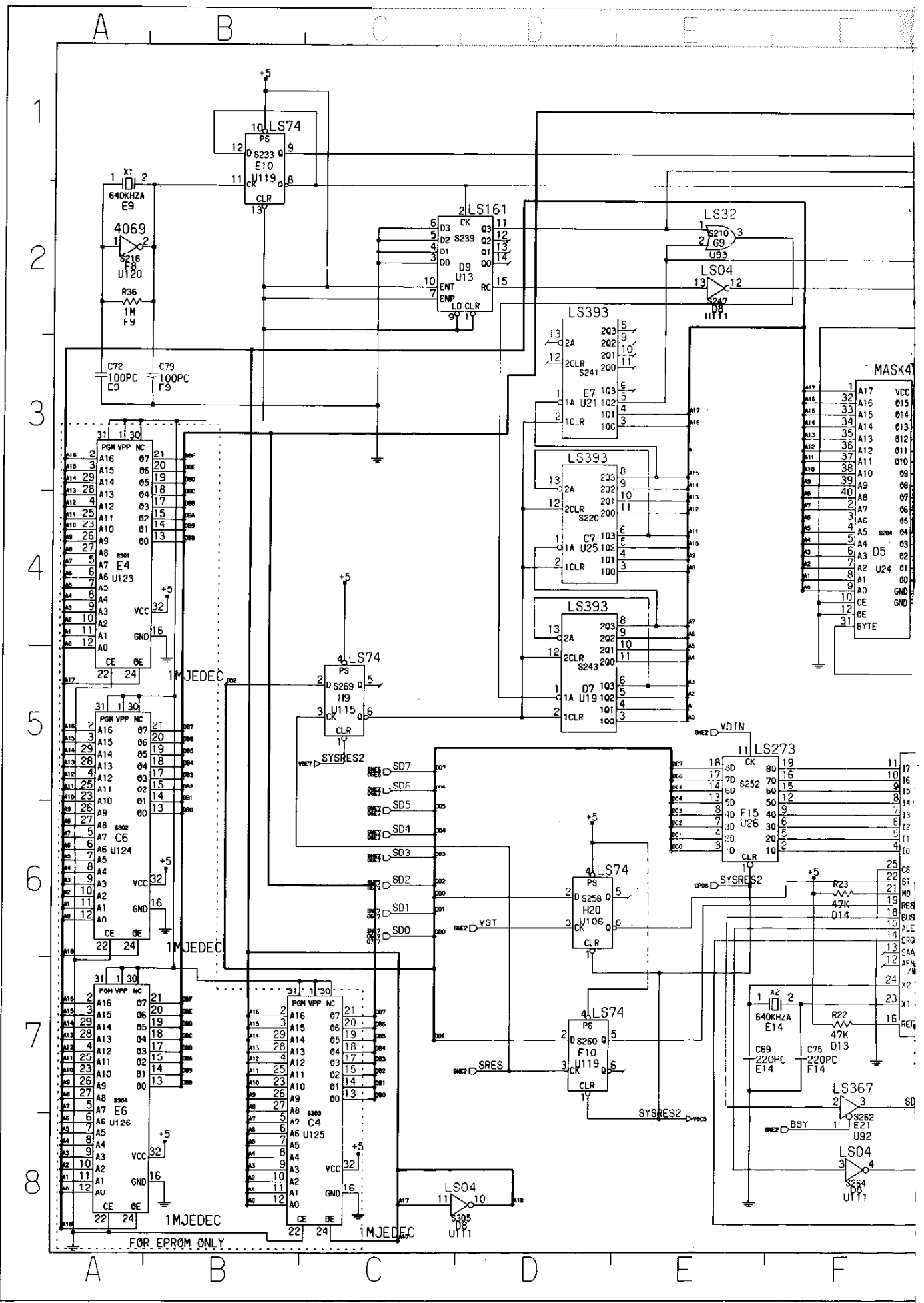

1
2
3
4
5
6
7
8

A B C D E F

MASK4

A17	1	A17	VCC
A16	32	A16	015
A15	33	A15	014
A14	34	A14	013
A13	35	A13	012
A12	36	A12	011
A11	37	A11	010
A10	38	A10	009
A9	39	A9	008
A8	40	A8	007
A7	41	A7	006
A6	42	A6	005
A5	43	A5	004
A4	44	A4	003
A3	45	A3	002
A2	46	A2	001
A1	47	A1	000
A0	48	A0	GND
	49		GND
	50		CE
	51		OE
	52		BYTE

FOR EPROM ONLY

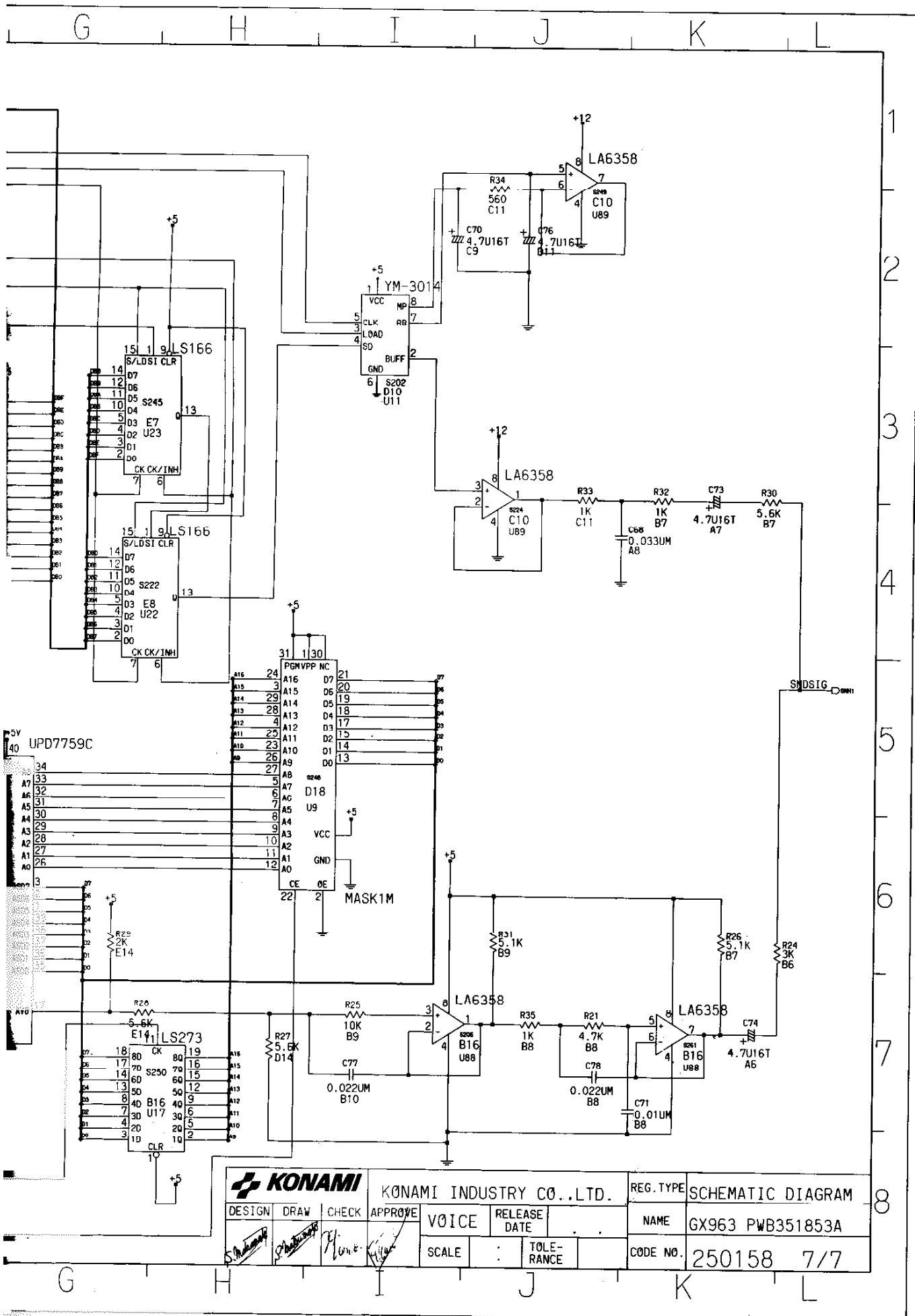

KONAMI				KONAMI INDUSTRY CO., LTD.		REG. TYPE	SCHEMATIC DIAGRAM
DESIGN	DRAW	CHECK	APPROVE	VOICE	RELEASE DATE	NAME	GX963 PWB351853A
						CODE NO.	250158 7/7
				SCALE	TOLE-RANCE		

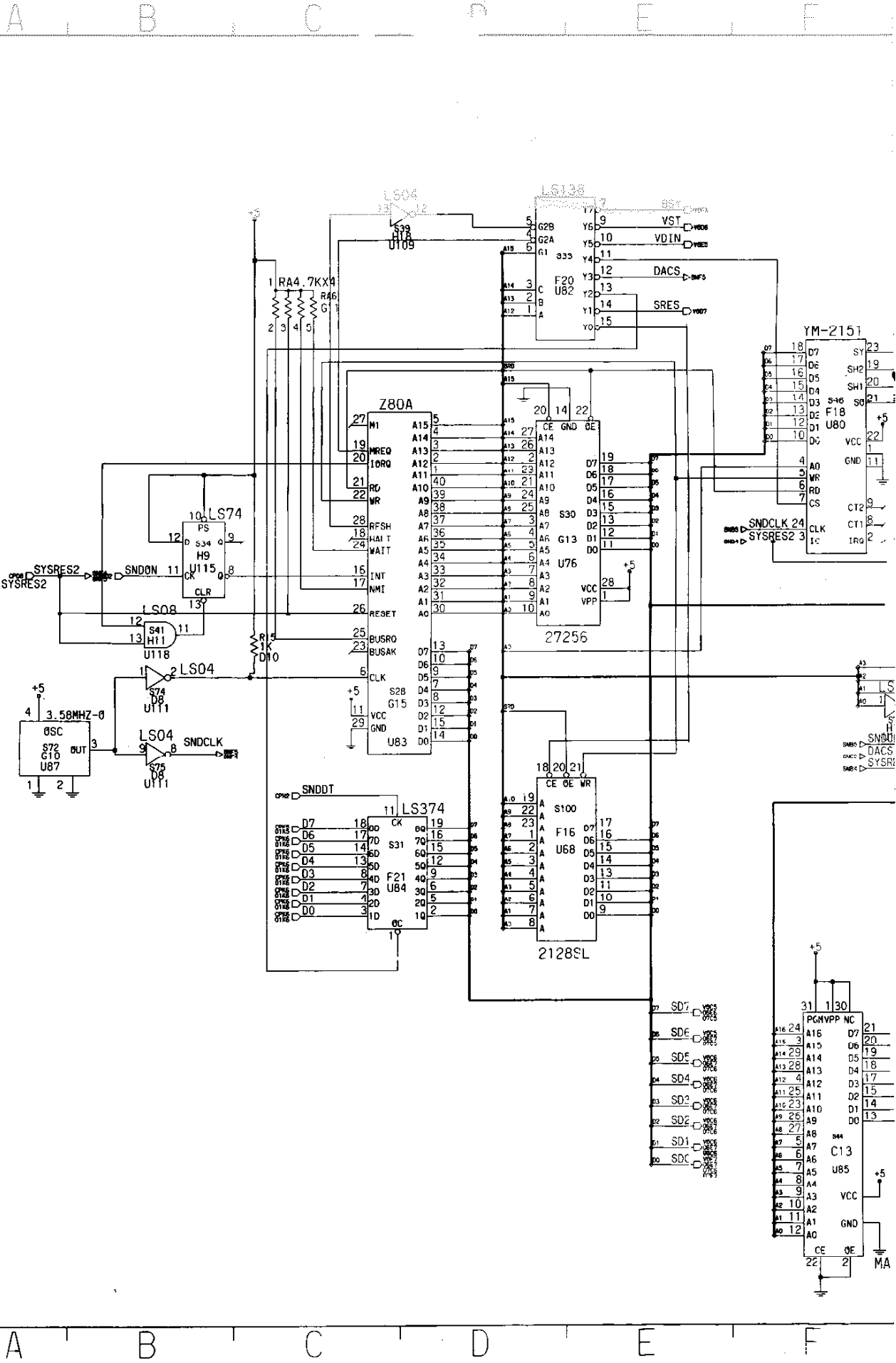

1
2
3
4
5
6
7
8

A B C D E F

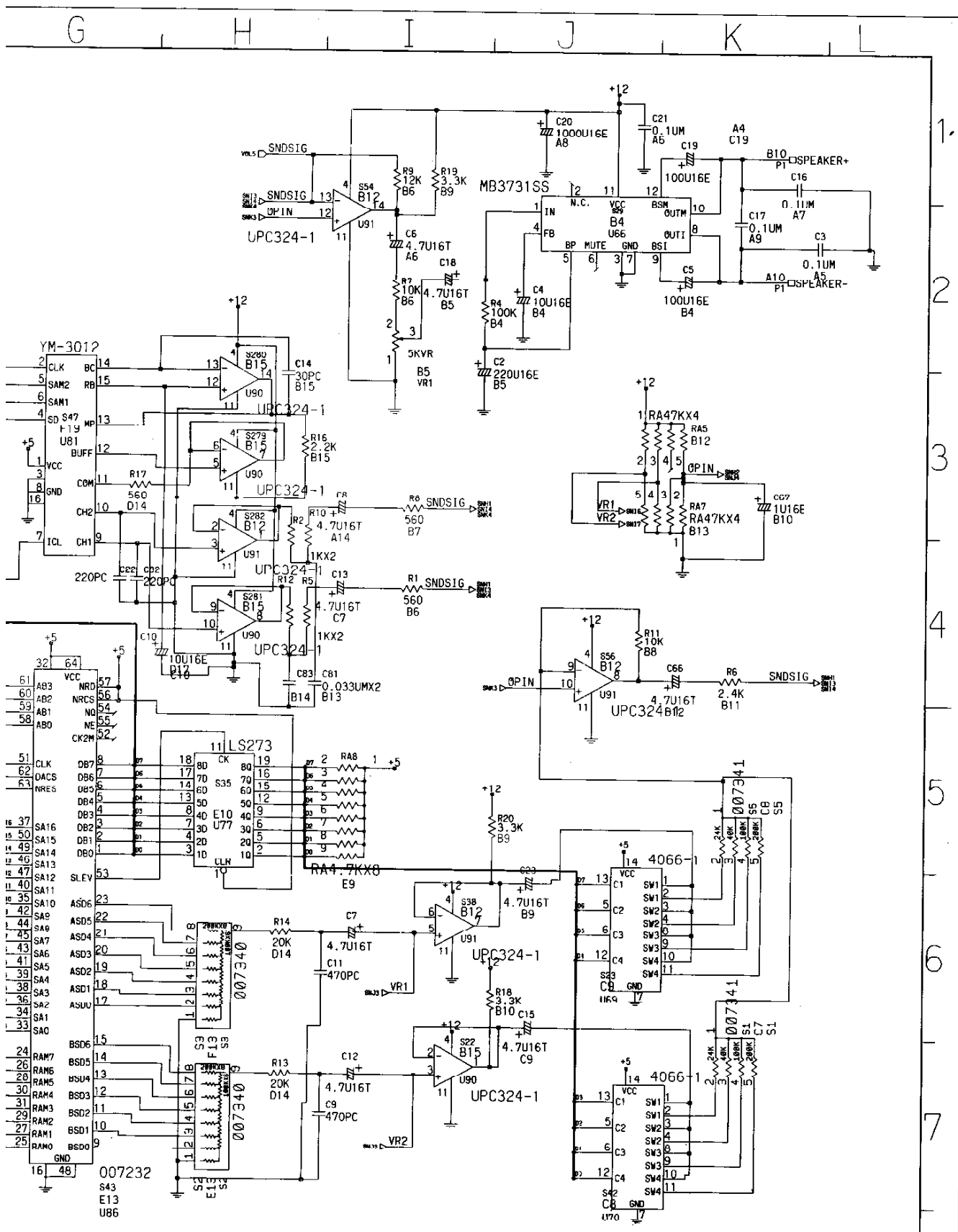

				KONAMI INDUSTRY CO., LTD.		REG. TYPE	SCHEMATIC DIAGRAM
DESIGN	DRAW	CHECK	APPROVE	SND	RELEASE DATE	NAME	GX963 PWB351853A
				SCALE	TOLE-RANCE	CODE NO.	250158 6/7

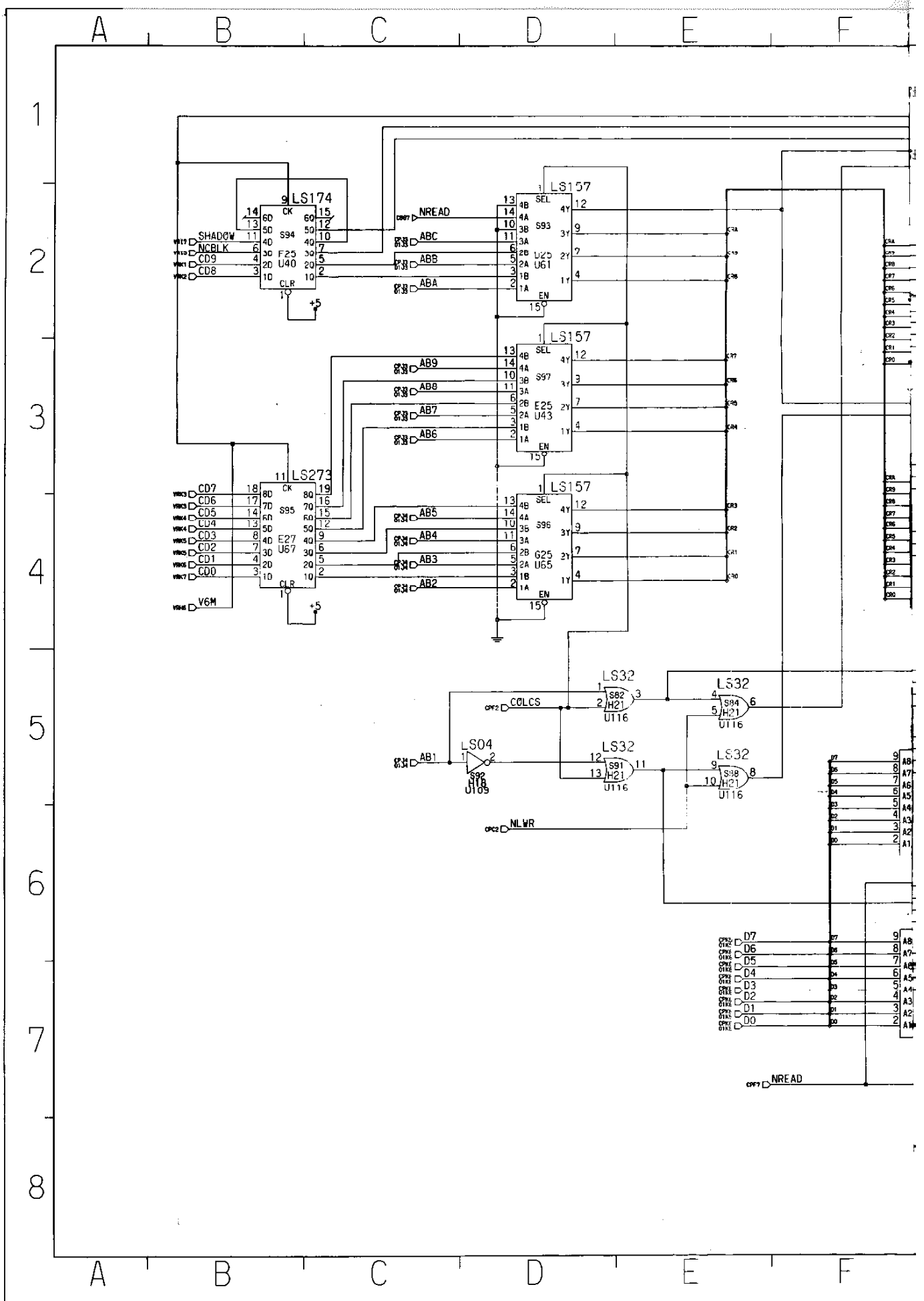

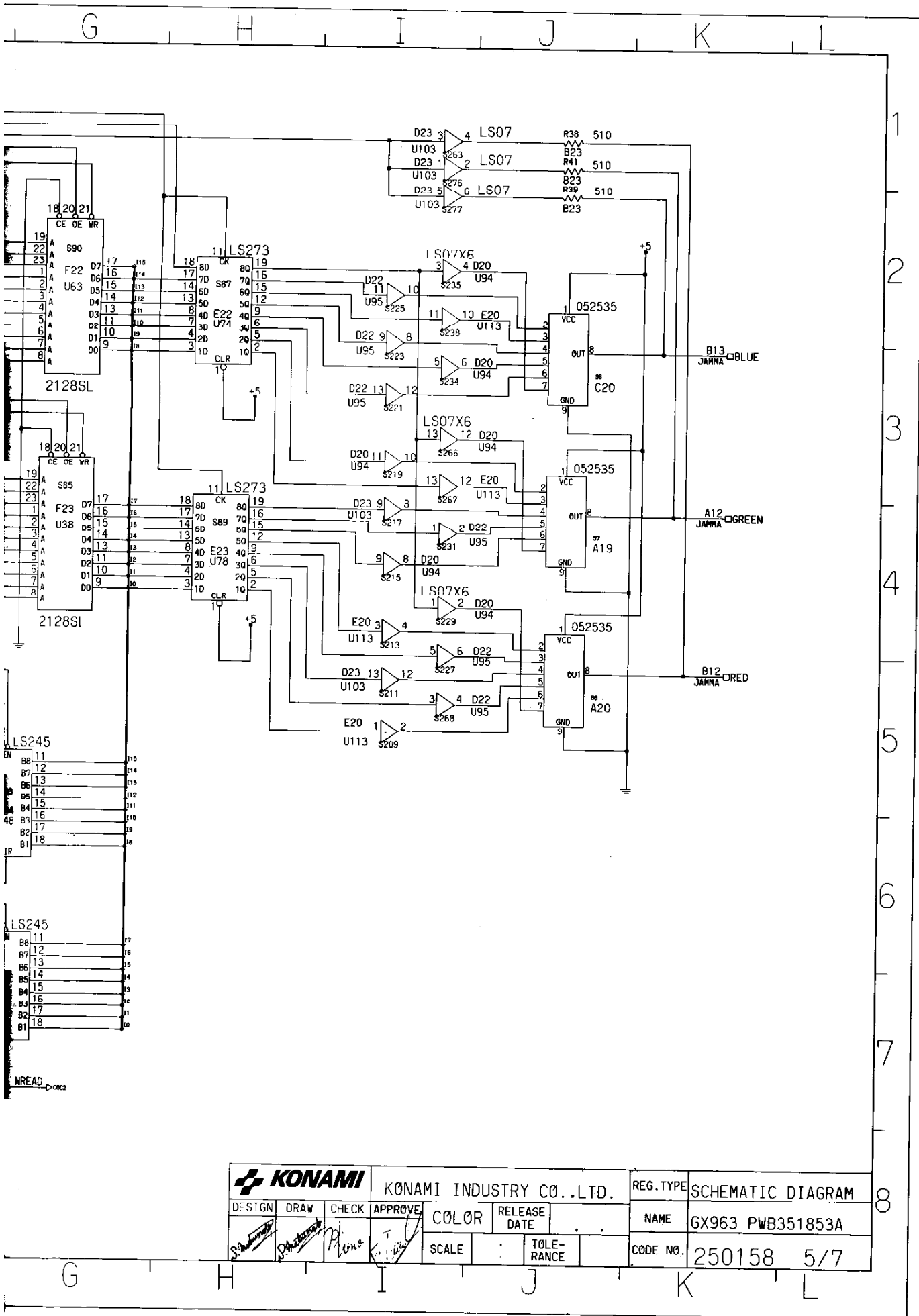

KONAMI				KONAMI INDUSTRY CO.,LTD.		REG. TYPE	SCHEMATIC DIAGRAM
DESIGN	DRAW	CHECK	APPROVE	COLOR	RELEASE DATE	NAME	GX963 PWB351853A
				SCALE	TOLE-RANCE	CODE NO.	250158 5/7

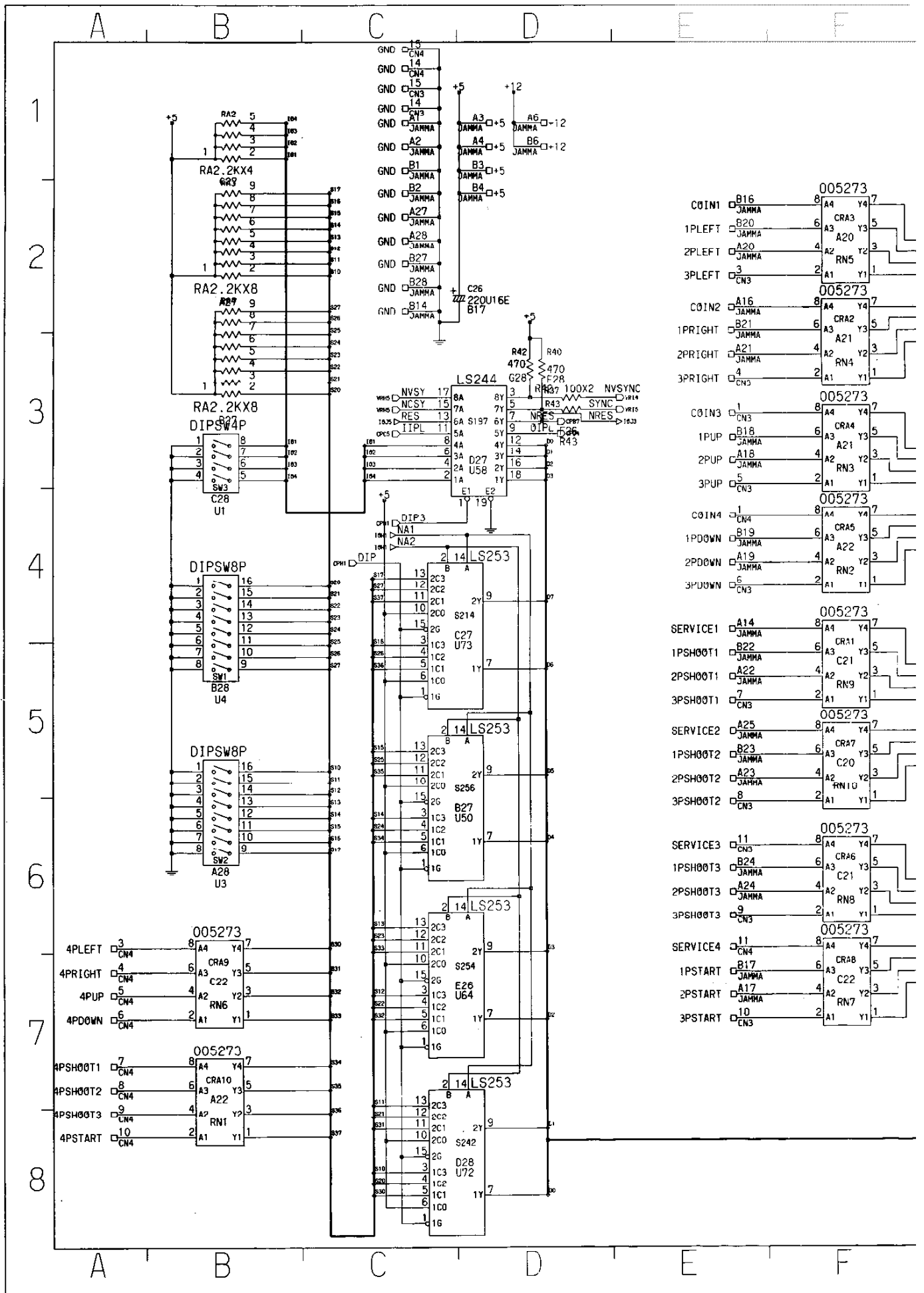

- | | | | | | |
|----------|-----|---|----|------|---|
| COIN1 | B16 | 8 | A4 | Y4 | 7 |
| 1PLEFT | B20 | 6 | A3 | CRA3 | 5 |
| 2PLEFT | A20 | 4 | A2 | A20 | 3 |
| 3PLEFT | 3 | 2 | A1 | RN5 | 1 |
| COIN2 | A16 | 8 | A4 | Y4 | 7 |
| 1PRIGHT | B21 | 6 | A3 | CRA2 | 5 |
| 2PRIGHT | A21 | 4 | A2 | A21 | 3 |
| 3PRIGHT | 4 | 2 | A1 | RN4 | 1 |
| COIN3 | 1 | 8 | A4 | Y4 | 7 |
| 1PUP | B18 | 6 | A3 | CRA4 | 5 |
| 2PUP | A18 | 4 | A2 | A21 | 3 |
| 3PUP | 5 | 2 | A1 | RN3 | 1 |
| COIN4 | 1 | 8 | A4 | Y4 | 7 |
| 1PDOWN | B19 | 6 | A3 | CRA5 | 5 |
| 2PDOWN | A19 | 4 | A2 | A22 | 3 |
| 3PDOWN | 5 | 2 | A1 | RN2 | 1 |
| SERVICE1 | A14 | 8 | A4 | Y4 | 7 |
| 1PSHOOT1 | B22 | 6 | A3 | CRA1 | 5 |
| 2PSHOOT1 | A22 | 4 | A2 | C21 | 3 |
| 3PSHOOT1 | 7 | 2 | A1 | RN9 | 1 |
| SERVICE2 | A25 | 8 | A4 | Y4 | 7 |
| 1PSHOOT2 | B23 | 6 | A3 | CRA7 | 5 |
| 2PSHOOT2 | A23 | 4 | A2 | C20 | 3 |
| 3PSHOOT2 | 8 | 2 | A1 | RN10 | 1 |
| SERVICE3 | 11 | 8 | A4 | Y4 | 7 |
| 1PSHOOT3 | B24 | 6 | A3 | CRA6 | 5 |
| 2PSHOOT3 | A24 | 4 | A2 | C21 | 3 |
| 3PSHOOT3 | 9 | 2 | A1 | RN8 | 1 |
| SERVICE4 | 11 | 8 | A4 | Y4 | 7 |
| 1PSTART | B17 | 6 | A3 | CRA8 | 5 |
| 2PSTART | A17 | 4 | A2 | C22 | 3 |
| 3PSTART | 10 | 2 | A1 | RN7 | 1 |

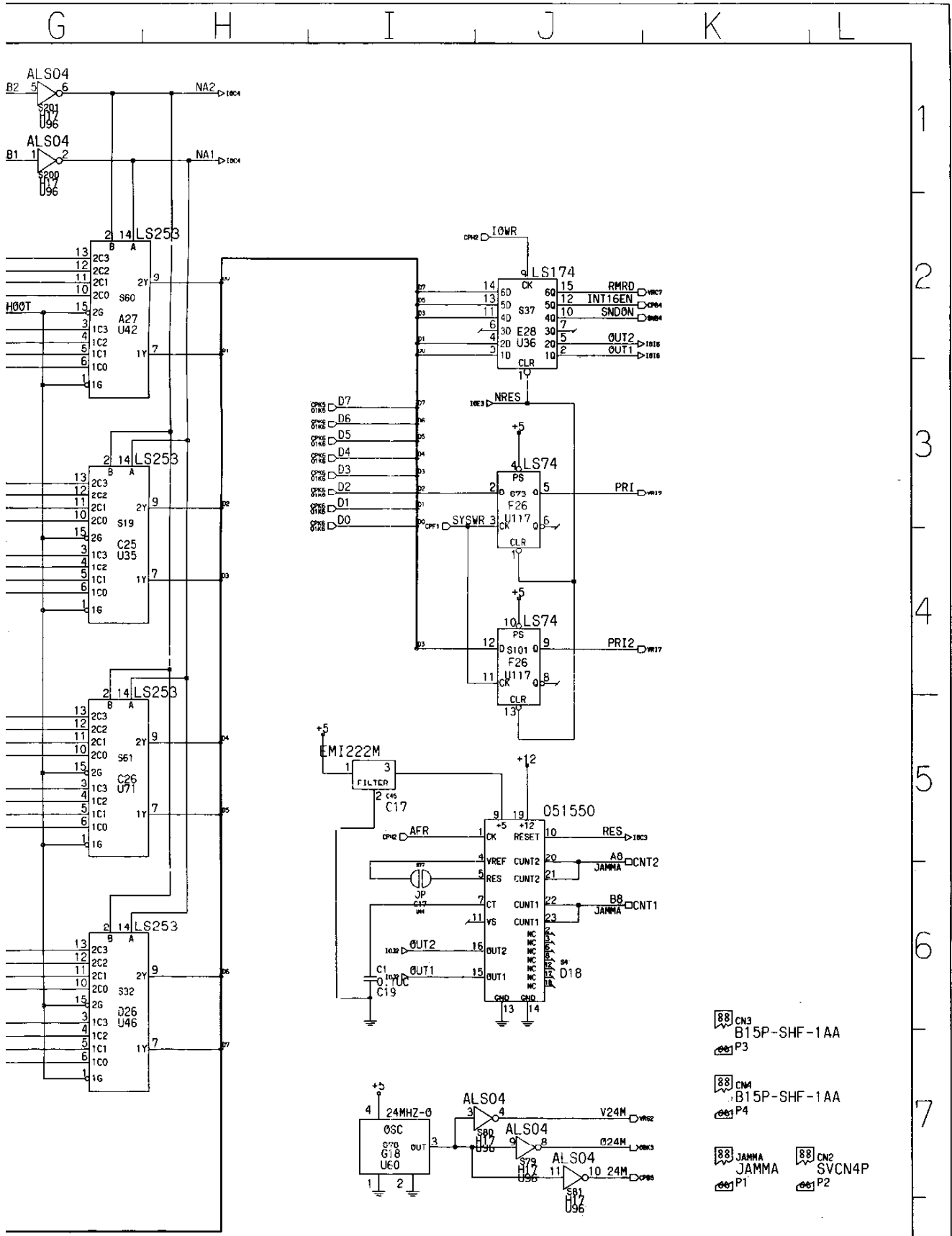

				KONAMI INDUSTRY CO.,LTD.		REG. TYPE	SCHEMATIC DIAGRAM	
DESIGN	DRAW	CHECK	APPROVE	I0	RELEASE DATE	NAME	GX963 PWB351853A	
<i>[Signature]</i>	<i>[Signature]</i>	<i>[Signature]</i>	<i>[Signature]</i>	SCALE	TOLE-RANCE	CODE NO.	250158 4/7	

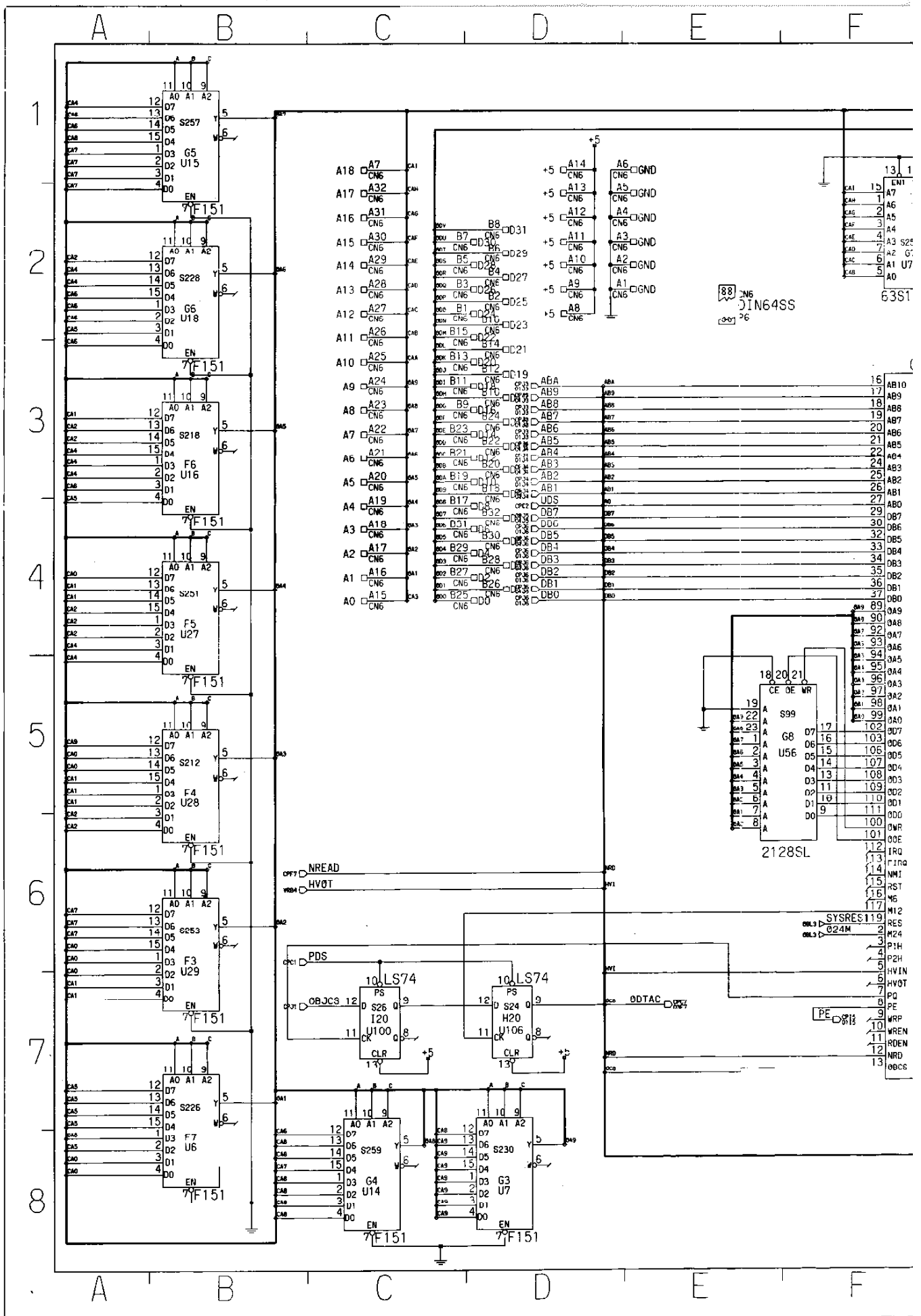

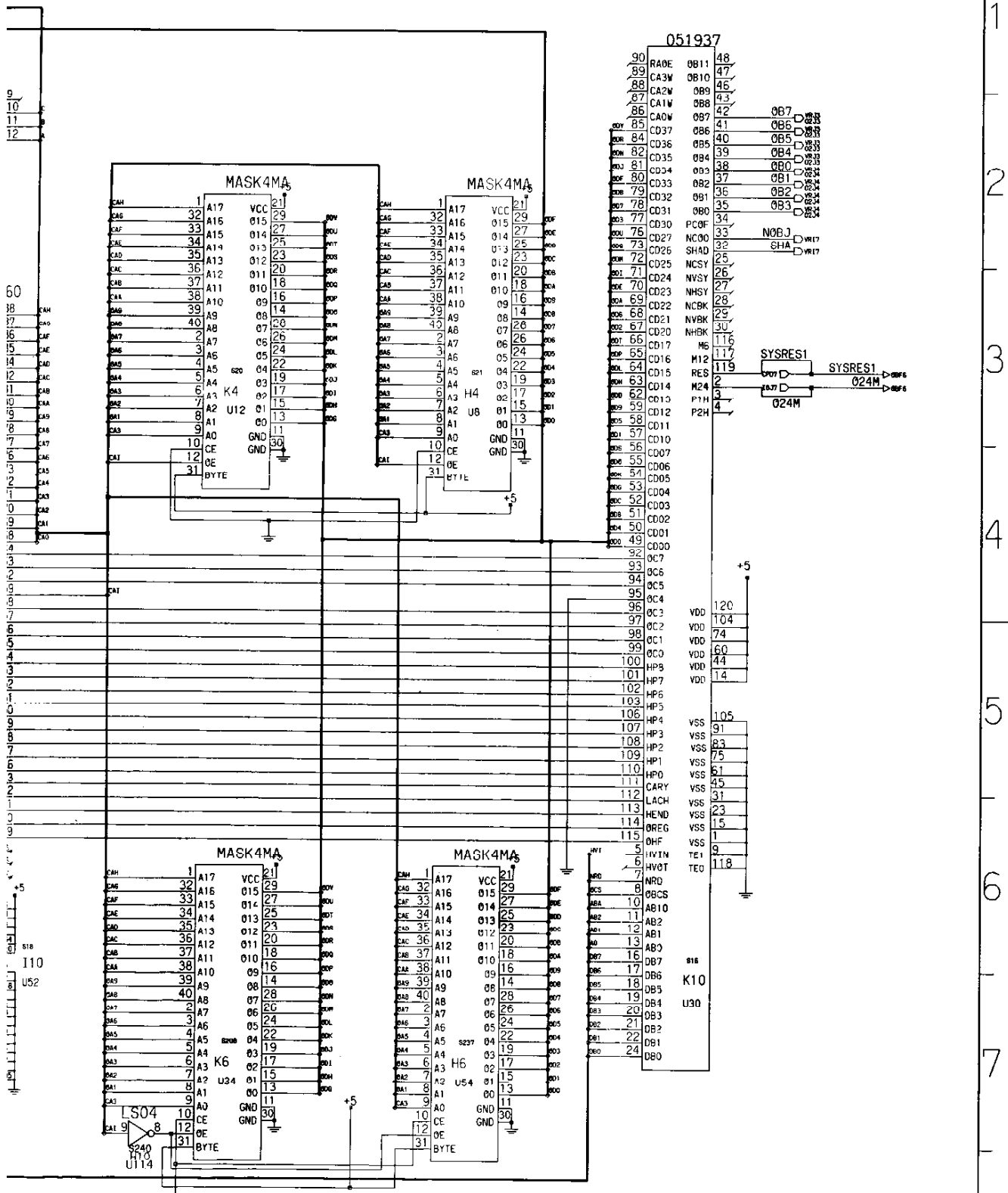

KONAMI				KONAMI INDUSTRY CO., LTD.		REG. TYPE	SCHEMATIC DIAGRAM
DESIGN	DRAW	CHECK	APPROVE	OBJ	RELEASE DATE	NAME	GX963 PWB351853A
				SCALE	TOLERANCE	CODE NO.	250158 3/7

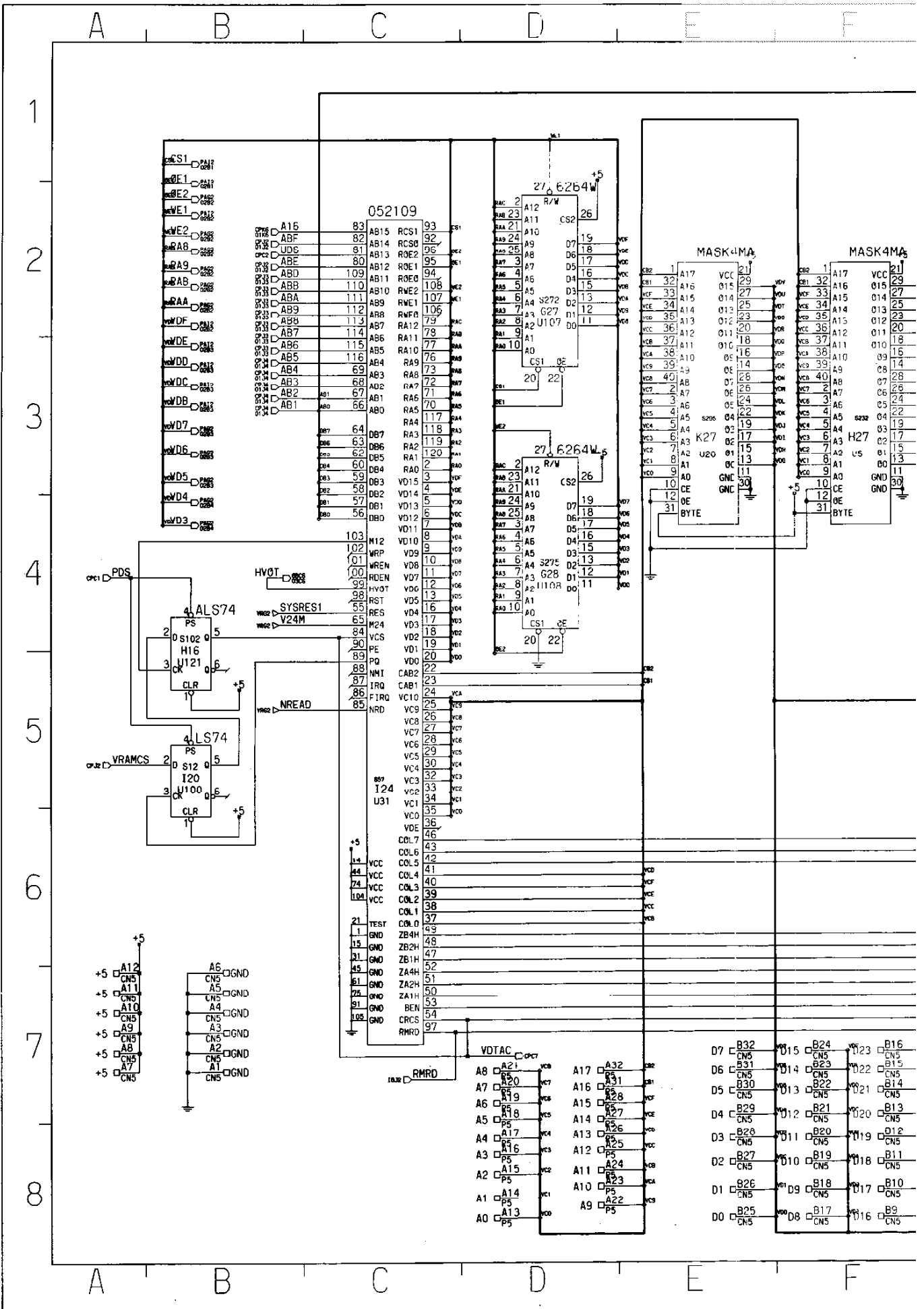

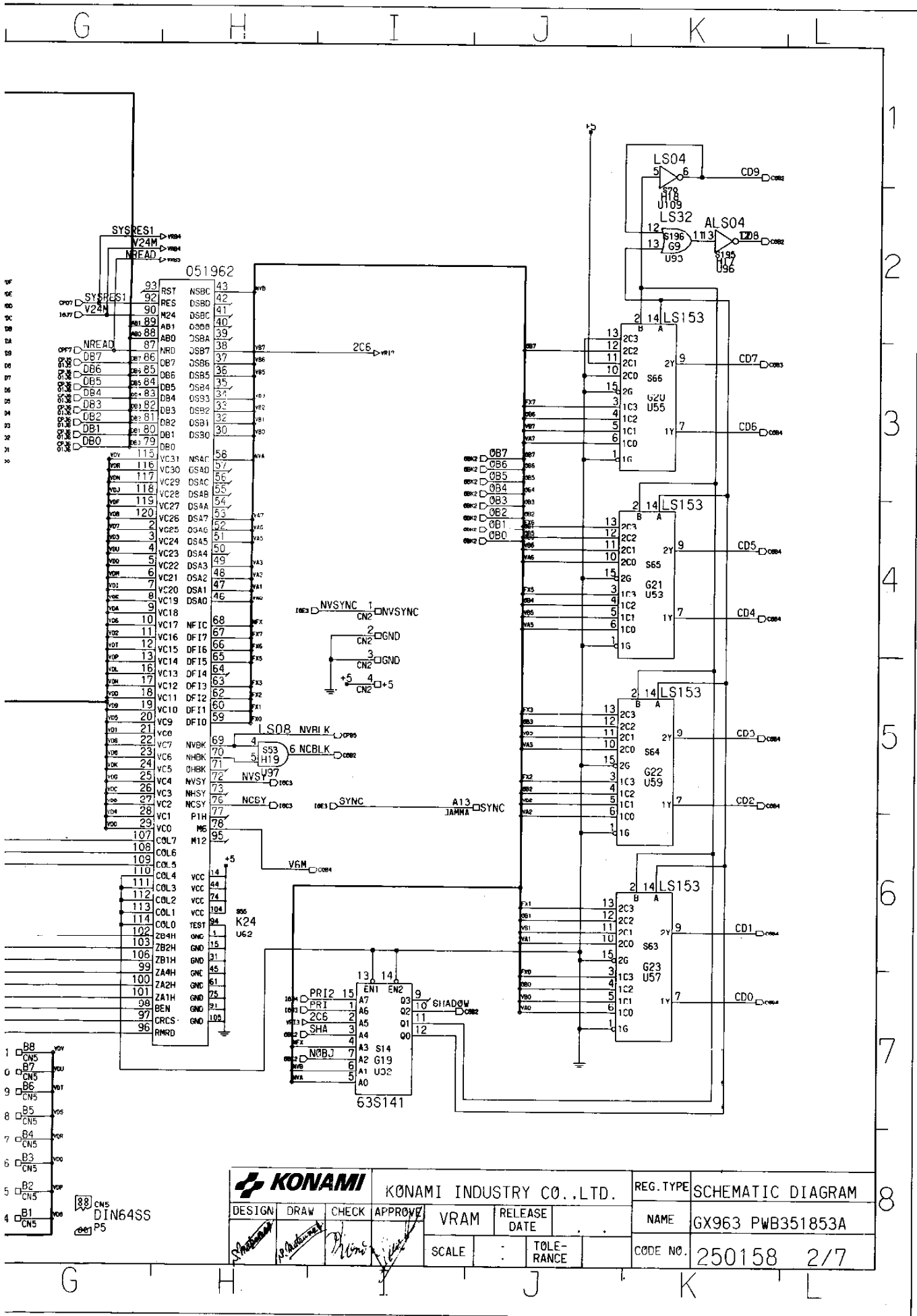

KONAMI				KONAMI INDUSTRY CO.,LTD.		REG. TYPE	SCHEMATIC DIAGRAM
DESIGN	DRAW	CHECK	APPROVE	VRAM	RELEASE DATE	NAME	GX963 PWB351853A
				SCALE	TOLE-RANCE	CODE NO.	250158 2/7

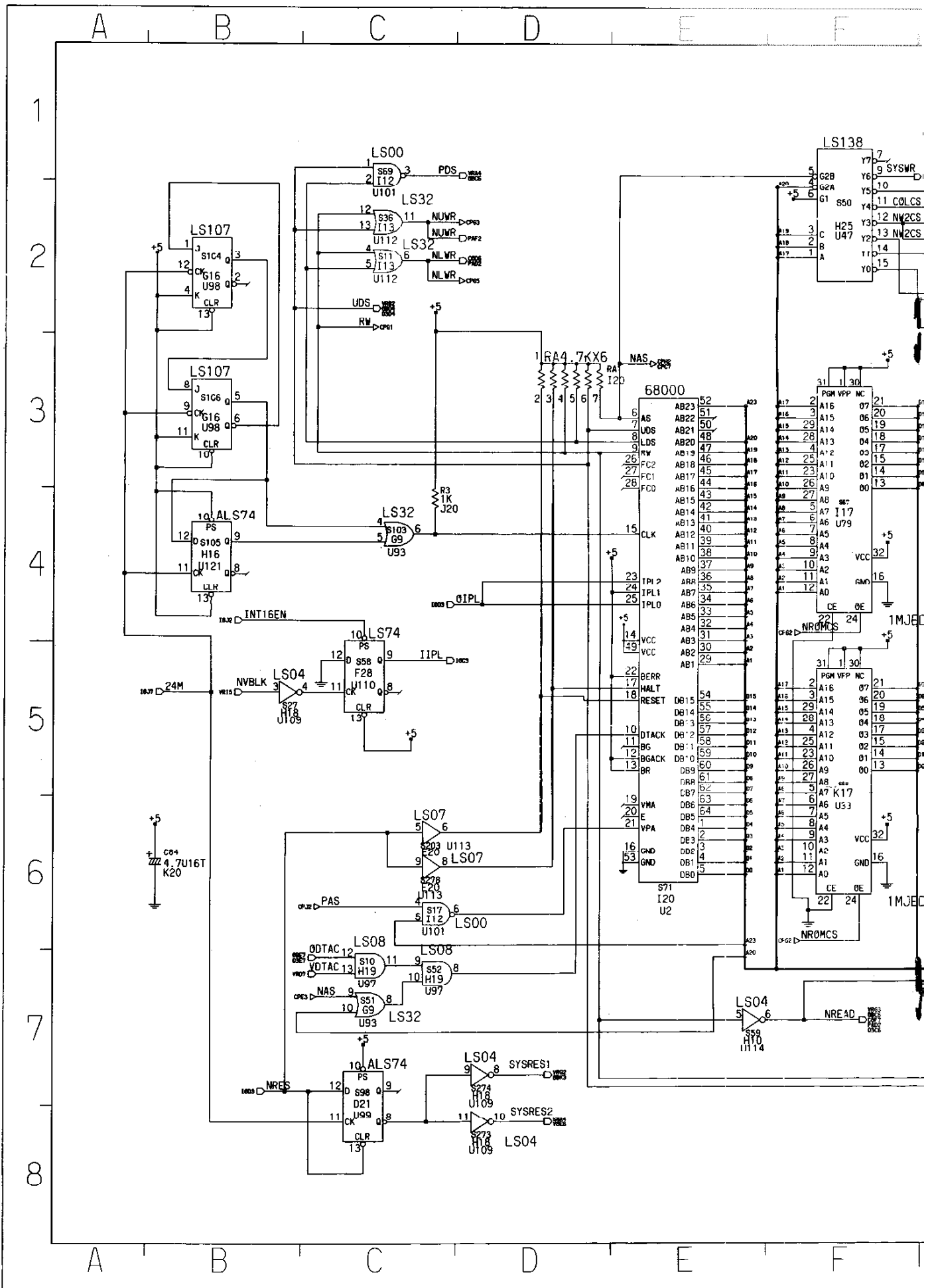

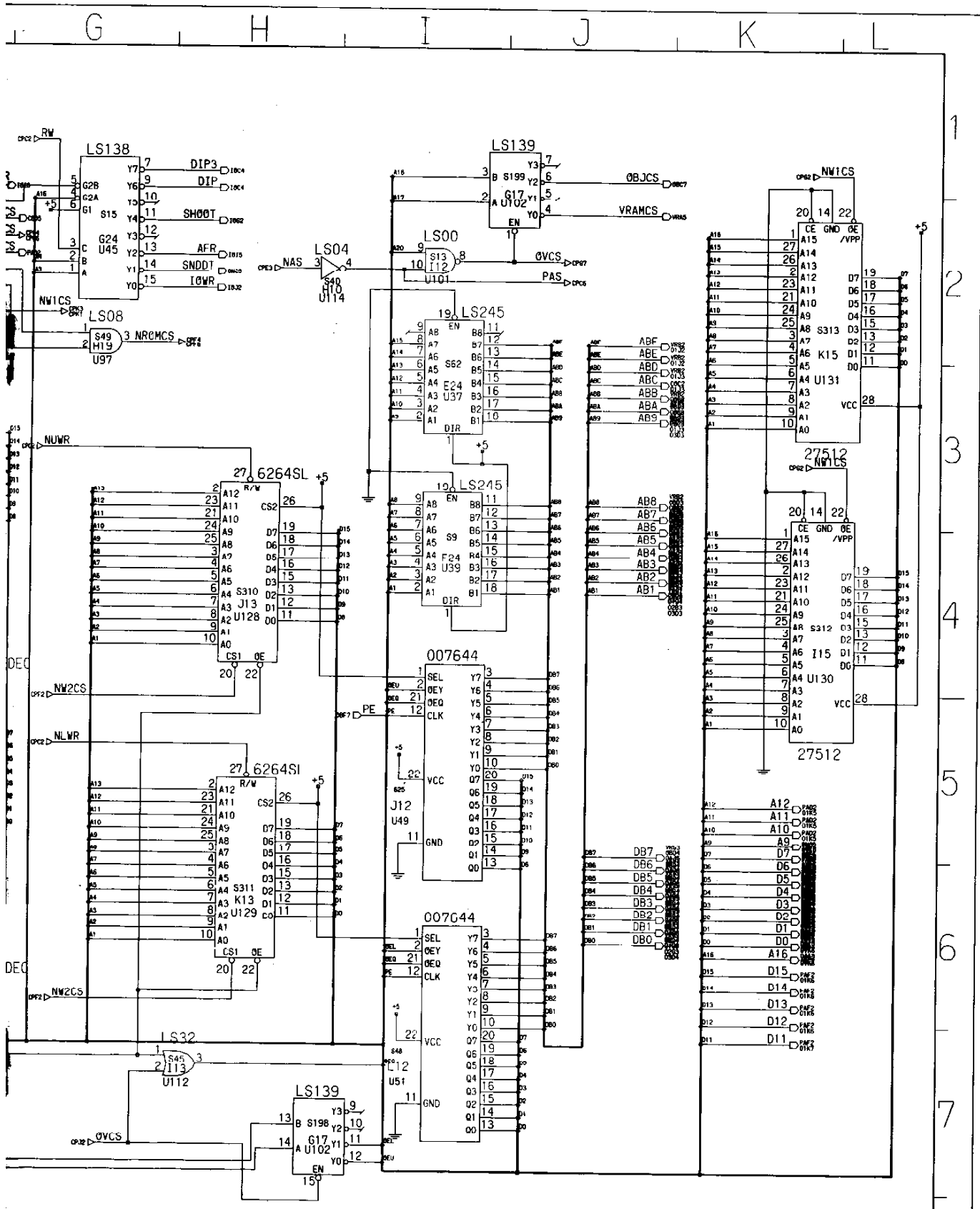

KONAMI				KONAMI INDUSTRY CO., LTD.		REG. TYPE	SCHEMATIC DIAGRAM
DESIGN	DRAW	CHECK	APPROVE	CPU	RELEASE DATE	NAME	GX963 PWB351853A
				SCALE	TOLE-RANCE	CODE NO.	250158 1/7

USER INFORMATION
WARNING

F.C.C. REGULATION COMPLIANCE

THIS EQUIPMENT COMPLIES WITH THE REQUIREMENTS IN PART 15 OF FCC RULES FOR A CLASS A COMPUTING DEVICE. OPERATION OF THIS EQUIPMENT IN A RESIDENTIAL AREA MAY CAUSE UNACCEPTABLE INTERFERENCE TO RADIO AND TV RECEPTION, REQUIRING THE OPERATOR TO TAKE WHATEVER STEPS ARE NECESSARY TO CORRECT THE INTERFERENCE.



900 Deerfield Parkway, Buffalo Grove, Illinois 60089-4510
Telephone: (312) 215-5100, Telex: 6871385 KONAM UW, Fax: (312) 215-5122