

MRP-100NK

Pneumatic Magnet

04/2021

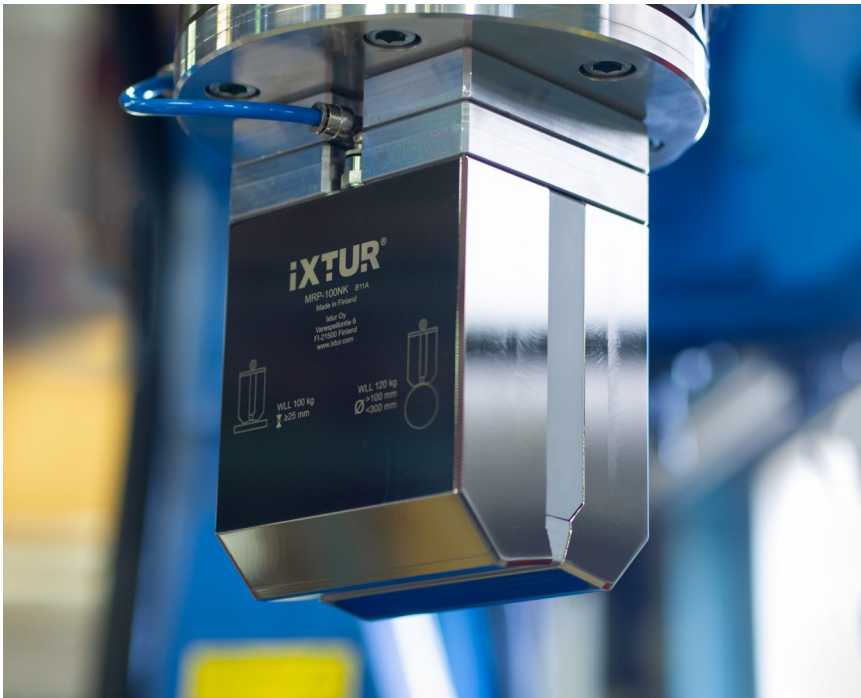

Ixtur MRP-100NK is a pneumatically controlled permanent magnet that is suitable for gripping parts with different shapes.

The MRP-100NK is optimized for picking up small cylinders that are close to each other. The magnet is able to pick up a single $\varnothing 50$ mm cylinder, even if the cylinders are next to each other.

The MRP-100NK also grips flat objects. The magnet is a versatile gripper for various loads, including narrow ones.

The MRP-100NK does not change its magnetic state in case of loss of compressed air.

TECHNICAL SPECIFICATIONS

Lifting capacity WLL [kg]	Gripping capacity [kg] [kN]	Residual gripping capacity, max. [kg]	Dimensions L x W x H [mm]	Weight [kg]	Operating temperature [°C]	Air pressure: functional range [bar]	Pneumatic tube outer diameter [mm]	Cycle time [s]
Flat: 100*	300* 2.9*	5	103 x 120 x 140	11	0 ... 50	5 ... 8	6.0	< 1
Round: 120**	360** 3.5**							

* plate thickness ≥ 25 mm

** cylinder diameter $100\text{mm} < \varnothing < 300\text{mm}$

Lifting capacity (WLL) is determined with a safety factor of 3.

Requirements for compressed air: Water separation, particle filter ≤ 5 μm .

Ixtur MRP magnets are maintenance-free and have a short cycle time, allowing high production speed and efficient automation.

Residual gripping capacity

The residual gripping capacity, i.e. the gripping capacity when the magnet is OFF, varies depending on the material and structure of the gripped part. In extreme cases, parts up to 5 kg may stay attached. The residual gripping capacity is greatest as long as the part continuously stays in contact with the magnet after the magnet has been turned from ON to OFF. If the amount of residual gripping capacity is critical in the application, pre-testing with the actual part is recommended.

The magnet can be used in various applications: lifters, robot grippers, fixtures, production automation, etc.



More information: www.ixtur.com

Company • Ixtur Ltd. is a Finnish magnet technology company established in 2010. Ixtur develops and manufactures permanent magnet based lifters, grippers and customer applications for machinery, welding, automation, robotics and material handling. Ixtur is focused on energy-efficient magnet components and applications.

ixTUR®

Lifting capacity vs. material thickness
- flat material -

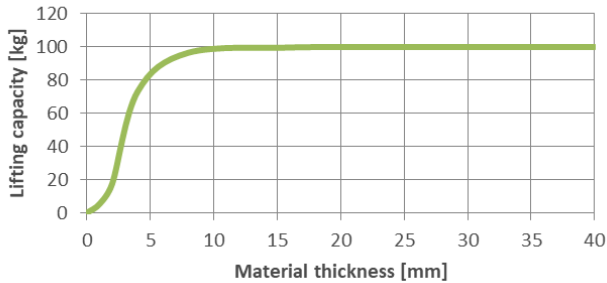

Lifting capacity vs. material thickness and airgap

The nominal lifting capacity can be obtained with the material thicknesses stated in the technical specifications table. The magnets can be used also with thinner materials, but have weaker grip, as shown in the graphs on this page. The given lifting capacities are valid for mild steel (S355).

The mounting parts that connect the MRP magnet's side plates together must be made of non-magnetic material e.g. aluminum or stainless steel.

Lifting capacity vs. cylinder diameter

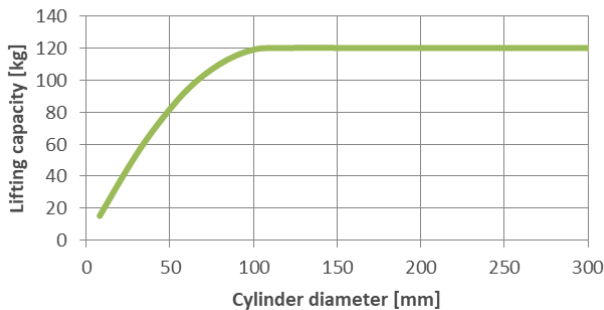

Lifting capacity vs. Airgap
- flat material -

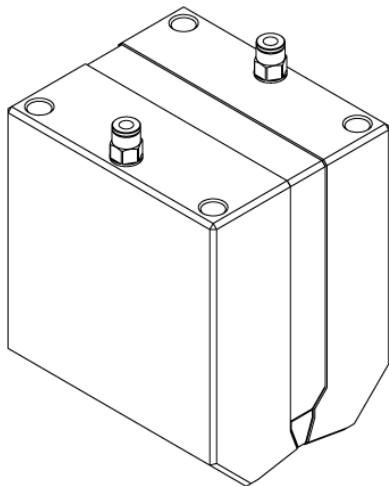
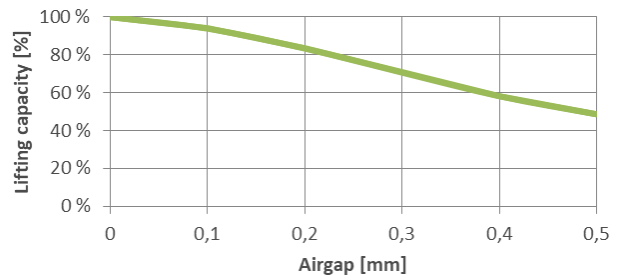

- Mounting threads M12, depth 24 mm, 4 pcs.
- Pneumatic connections, 2 pcs.
- Rapid fittings for plastic tubing
- Tube external dia 6 mm
- Threads 1/8, depth 10 mm

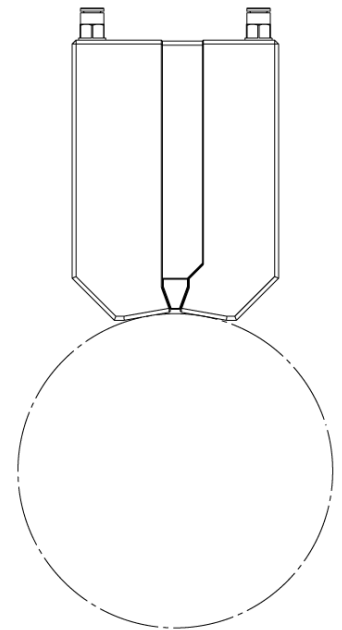
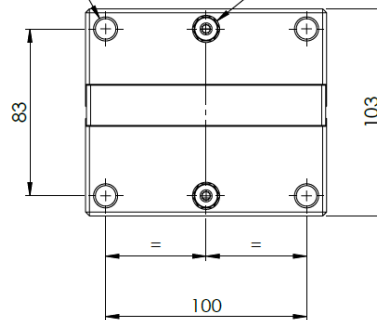

Gripping surface - Magnetic poles

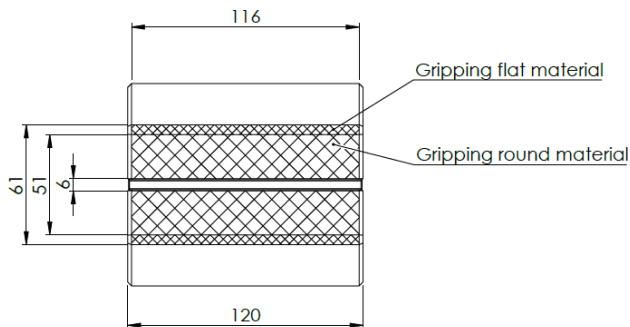

Company • Ixtur Ltd. is a Finnish magnet technology company established in 2010. Ixtur develops and manufactures permanent magnet based lifters, grippers and customer applications for machinery, welding, automation, robotics and material handling. Ixtur is focused on energy-efficient magnet components and applications.