

**AMG**

**Turntable Viella**

**Operating and installation manual**

# **AMG Viella V12 turntable**

## **Installation and operating instructions**

### **Unpacking:**

After opening the outer cardboard box you found this manual on top of the inner box. It would be best to leave the inner box in the outer and open it there.

Please take off the first foam cover. Underneath you find the power supply, the pickup arm ( if you ordered one ), and the cable to the mains. All the screw drivers are in the tone arm box.

Take all out and put it aside.

Take out all the foam, until you get to the turntable.

Now you can lift it out easily.

Please be careful the turntable is fairly heavy.

Place it on your rack. We recommend a granite plate to be put under the turntable.

The belt mounter together with two pieces of wood is in the bottom layer. In case you did not order a tone arm, you will also find the screw drivers there.

### **Assembling:**

Have a look at the spirit level in the plinth, if it indicates level no leveling action is required.

If it is not level take out the next foam layer off the box.

You find the platter, the record clamp and a box with hex head screwdrivers.

In the plinth are three access holes to the steel spike screws.

One is located left of the pickup arm board, the other one down by the speed selector-keys.

At a nine o clock position from the platter bearing is the third plug. Now you have access to the three spike screws build in the center of the two feet and the left side of the platter-bearing shroud.

Take the # 3 screwdriver and start with the spike in the bearing shroud. By turning the spike screw clockwise lift the turntable a few millimeters of the granite plate. Now continue with the two spike screws at the right side of the plinth until the your spirit level shows level. Now take the pickup arm out of its wooden box.

If you have ordered it together with a pickup cartridge it is all ready set at the factory and the only thing you have to do is sliding it in the mounting bushing on the arm board and secure it with the locking screw at the right of the bushing.

If you have the version with two cinch connecters at the right hand rear of the plinth then there is a connector installed in your arm board, which is fixed with a screw at the right side of the arm board. The thin wires from the cinch connecters are soldered to this connector in the arm board. Slide your tone arm carefully into the bushing on the arm board and push it into the connector. Tighten the locking screw at the right side of the bushing. If you need to hight adjust your tone arm, you have to loosen the screw in the bushing and the screw in the arm board!

If your phono cable connects direct into the arm, route it through the square opening in the wooden frame and plug it into the arm post.

If you ordered the version without wooden frame the cable goes direct to the arm post.

If you ordered the arm with flying leads coming out of the shaft, you have to solder them to your connectors.

For adjusting the pickup arm or installing a cartridge, please see your arm manual.

Now inspect the platter seat at the sub platter for cleanliness before you put the platter on it. Take your platter and the belt mounter. Slip the mounter over the record spindle. Lay your platter inverted on a soft surface. Sling the drive belt around the platter pulley in the platter and around the 2 wooden pins. Now place the two wooden blocks opposed on the plinth. Place the platter over the bearing so it rests on the wooden blocks and the motor pulley is located within the belt. Now put the belt in the groove on the pulley by using both hands. Make sure, it is in the groove. You can do it by your self, but it is easier to have somebody else to pull out the wooden blocks, while you lift the platter by just a few millimeters. Do not lift it too high; the belt could come off again. Now lower the platter gently on to the sub platter. Now look underneath your platter, turn it by hand and check if the belt is correctly mounted. This may sound a little complicated but it is easier as it seems to be. You will not take off your platter very often and this design gives you better sound, and protects your belt against dust and ultraviolet rays.

Out of the motor housing under the plinth runs the power supply cable, which supplies the motor control, the motor and the speed control keys with 24 volts. Connect the cable to the power supply box and connect the box to the mains. Set the switch at the power supply to on.

All three speed control keys illuminate red. If you touch on key it illuminates green and the platter starts spinning.

All three speeds are set correct by the factory. If you find it necessary to correct the speed for any reason proceed as described.

Use a stroboscopic disc. Touch the key of the speed you like to alter by at least five seconds. Now you have entered the programmable mode. With the two remaining keys you can speed up or slow the platter. The left key decelerates the right one speeds up the platter.

Every touch changes the speed by 0,1%. After setting the speed touch the key of the selected speed again for at least five seconds and the processor is back in the normal operating mode. The speed is very constant kept by a 20 kHz crystal.

For stopping the platter touch the selected key which illuminates green during operation and it lights up red. You may use your hand to bring the platter to a stop, because of the excellent bearing it will continue spinning for quite a while, after selecting off.

For shutting off your turntable while it is not in use, it is highly recommended to switch your power supply to off or disconnect it from mains.

Enjoy your music

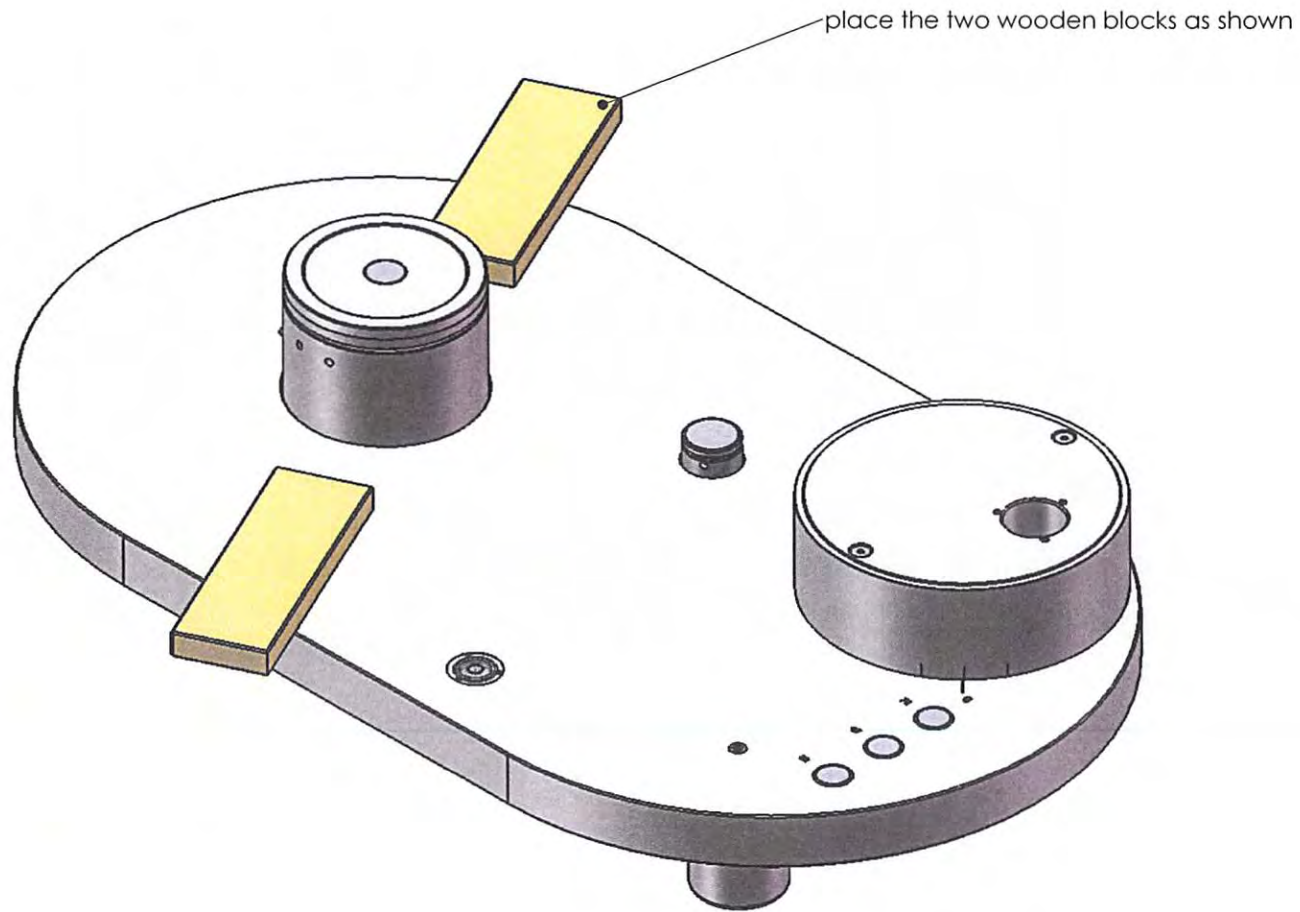

place the two wooden blocks as shown

UNLESS OTHERWISE SPECIFIED:  
 DIMENSIONS ARE IN MILLIMETERS  
 SURFACE FINISH:  
 TOLERANCES:  
 LINEAR:  
 ANGULAR:

FINISH:

DEBUR AND  
 BREAK SHARP  
 EDGES

DO NOT SCALE DRAWING

REVISION +

Analog Manufaktur Germany

TITLE:

AMG Viella V12, instructions for  
 belt mounting and putting on the platter

DWG NO.

01020312

A3

SCALE:1:2

SHEET 1 OF 1

	NAME	SIGNATURE	DATE
DRAWN	Röschlau		02.03.12
CHK'D	+		+
APP'VD	+		+
MFG	+		+
Q.A	+		+

MATERIAL:

A

B

C

D

E

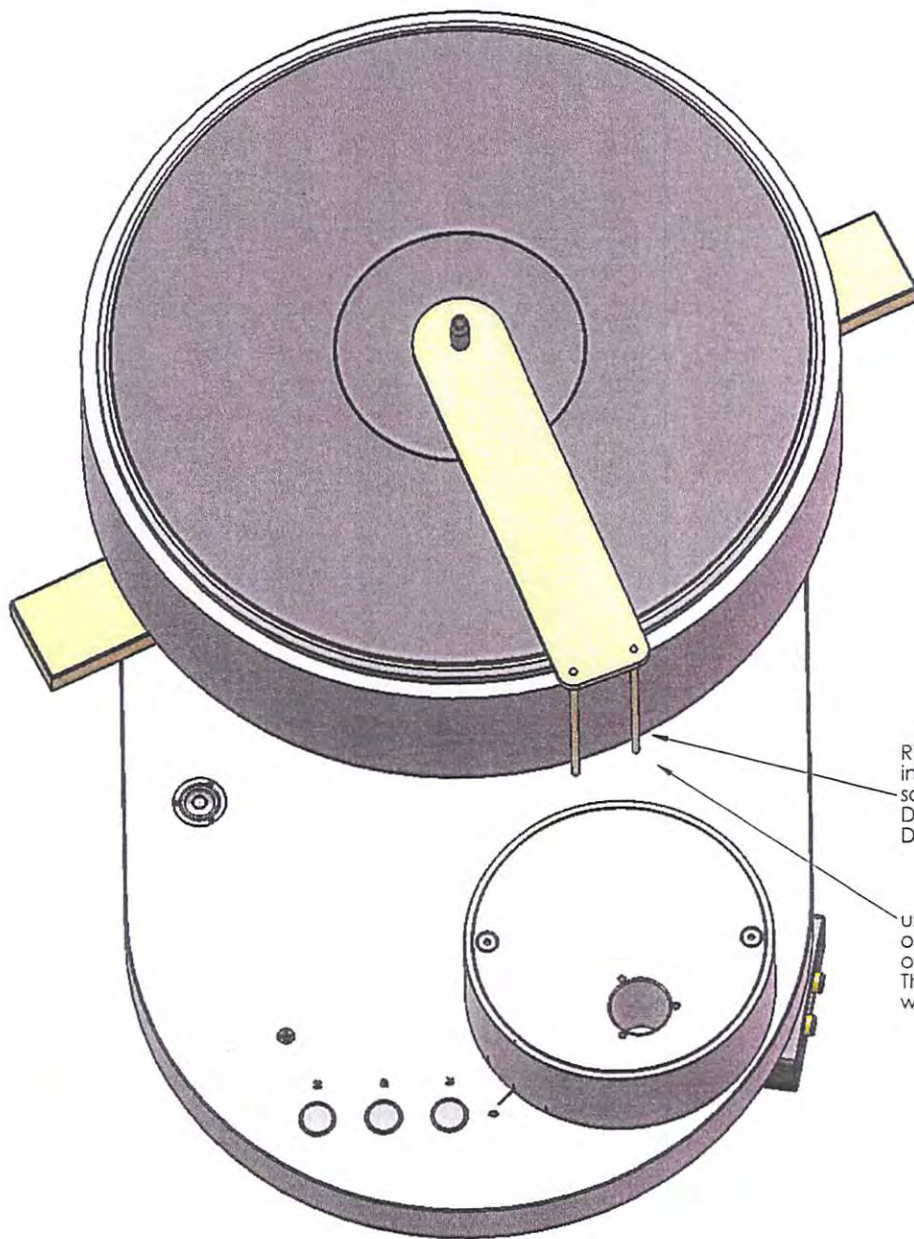

Riemen mit beiden Händen  
in die Rille auf der Motoreriemenscheibe legen.  
Dann die Holzklötze heraus ziehen.  
Den Teller dabei halten

use both hands to slide the drive belt  
off the wooden sticks into the groove  
of the motor pulley.  
Then have somebody pull out the  
wooden blocks

UNLESS OTHERWISE SPECIFIED: DIMENSIONS ARE IN MILLIMETERS		FINISH: *		DEBUR AND BREAK SHARP EDGES		DO NOT SCALE DRAWING		REVISION	
TOLERANCES: LINEAR: +/- 0,1 ANGULAR:						<b>Analog Manufaktur Germany</b>			
						TITLE: belt mounting instructions			
						DWG NO.		04090611	
								A4	
						SCALE:1:3		SHEET 1 OF 1	

UNLESS OTHERWISE SPECIFIED:  
DIMENSIONS ARE IN MILLIMETERS

FINISH:

\*

DEBUR AND  
BREAK SHARP  
EDGES

DO NOT SCALE DRAWING

REVISION

TOLERANCES:  
LINEAR: +/- 0,1  
ANGULAR:

**Analog Manufaktur Germany**

	NAME	SIGNATURE	DATE		
DRAWN	Röschlau		02.03.12		
CHK'D	*		*		
APPV'D	Röschlau		*		
F MFG	*		*		
Q.A	*		*	MATERIAL:	

TITLE: belt mounting instructions		DWG NO.		04090611		A4	
SCALE:1:3				SHEET 1 OF 1			

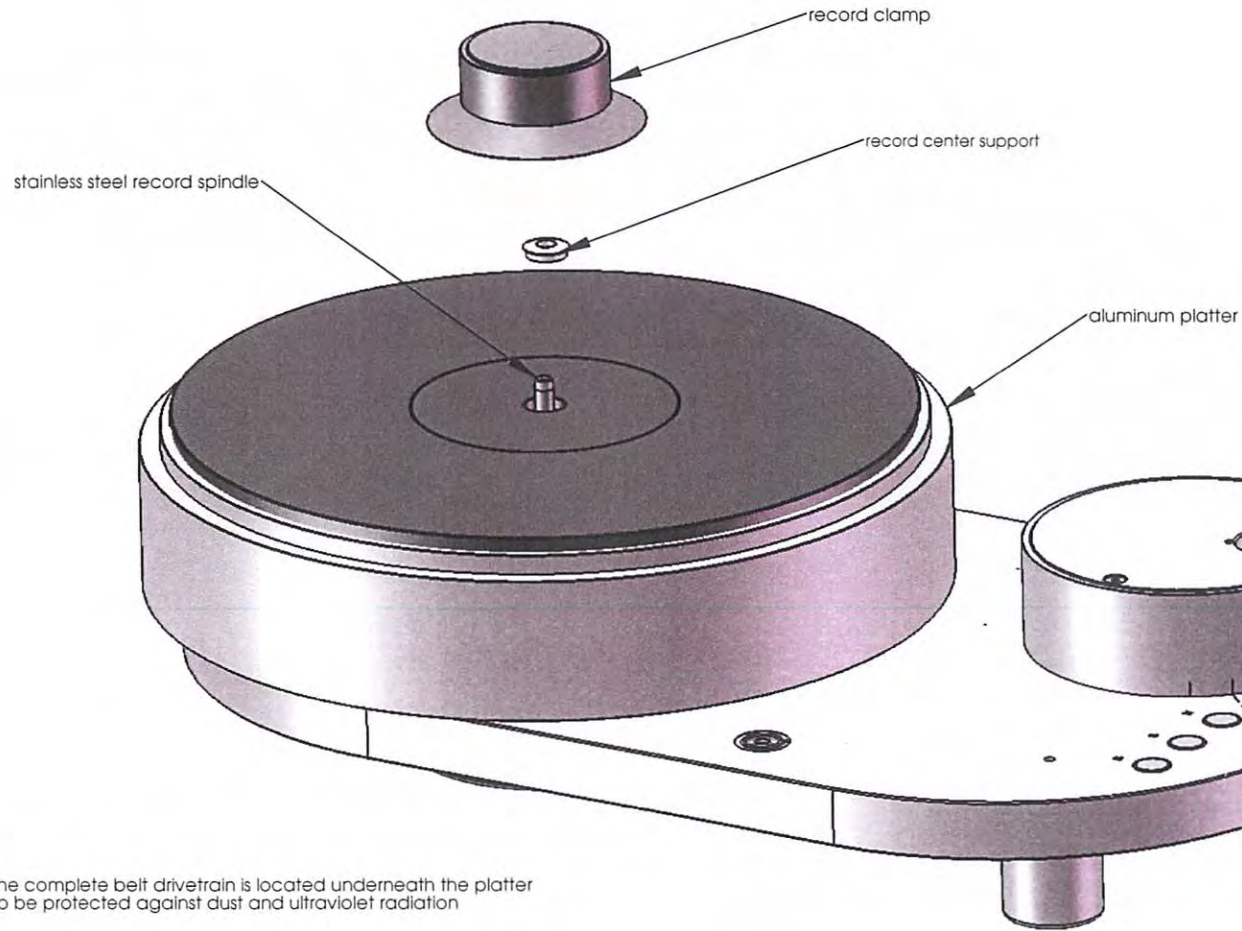

the complete belt drivetrain is located underneath the platter to be protected against dust and ultraviolet radiation

UNLESS OTHERWISE SPECIFIED: DIMENSIONS ARE IN MILLIMETERS				FINISH +		DEBUR AND BREAK SHARP EDGES		DO NOT SCALE DRAWING		REVISION +	
SURFACE FINISH: TOLERANCES: LINEAR: ANGULAR:								Analog Manufaktur Germany			
DRAWN		NAME	SIGNATURE	DATE			TITLE:				
CHKD		+		20.02.11			Viella turntable overview				
APPRD		+									
MFG		+									
QA		+			MATERIAL		DWG NO.		03200211		A3
							SCALE 1:2		SHEET 1 OF 1		

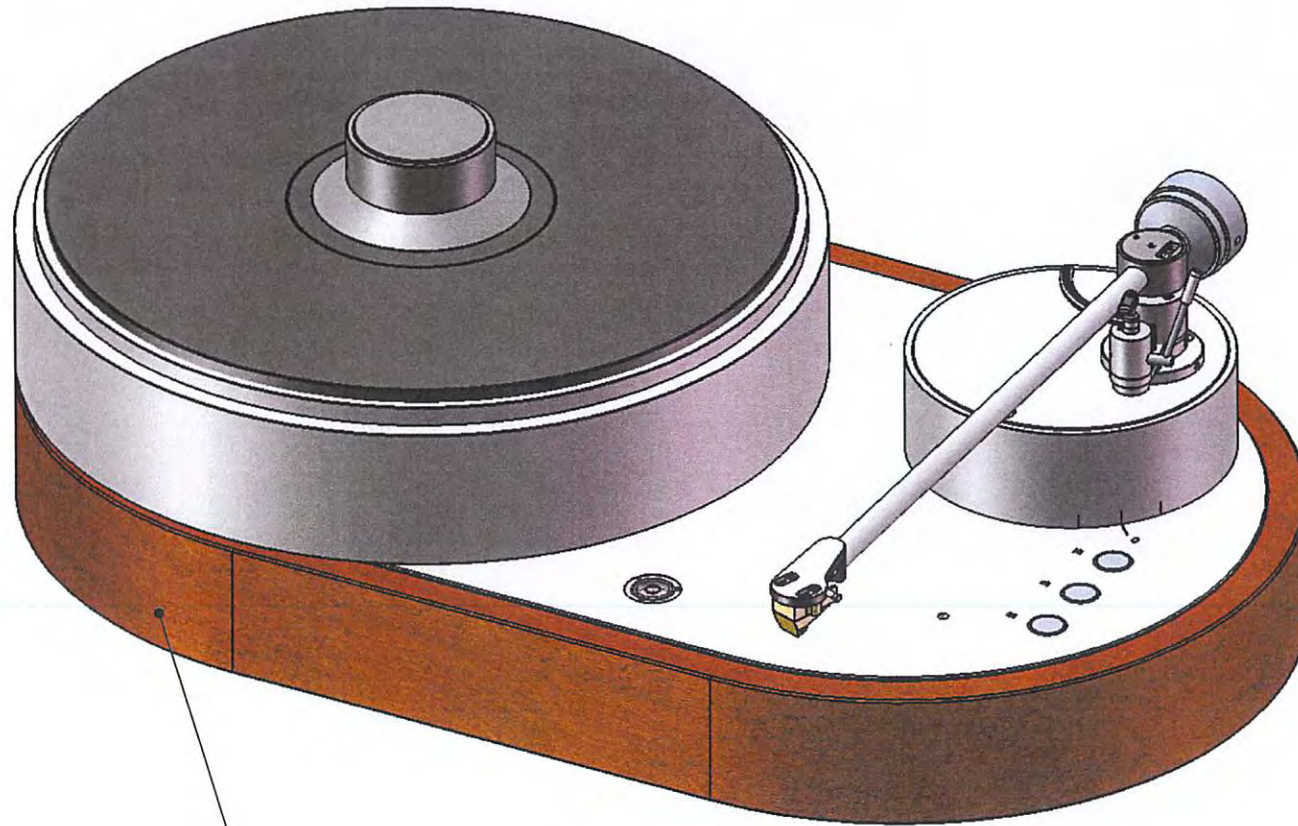

wooden skirt as option in cherry  
or maple wood or black lacquered

UNLESS OTHERWISE SPECIFIED: DIMENSIONS ARE IN MILLIMETERS				FINISH: +		DEBUR AND BREAK SHARP EDGES		DO NOT SCALE DRAWING		REVISION +	
SURFACE FINISH:								Analog Manufaktur Germany			
TOLERANCES:											
LINEAR:								TITLE Viella turntable with wooden frame and 12J2 tonearm			
ANGULAR:											
	NAME	SIGNATURE	DATE					DWS NO. 01220211			
DRAWN	Roeschku		22.02.11								
CHK'D	+		+					SCALE 1:2		SHEET 1 OF 1	
APP'VD	+		+								
MFG	+		+					A3			
IQA	+		+								
								MATERIAL			

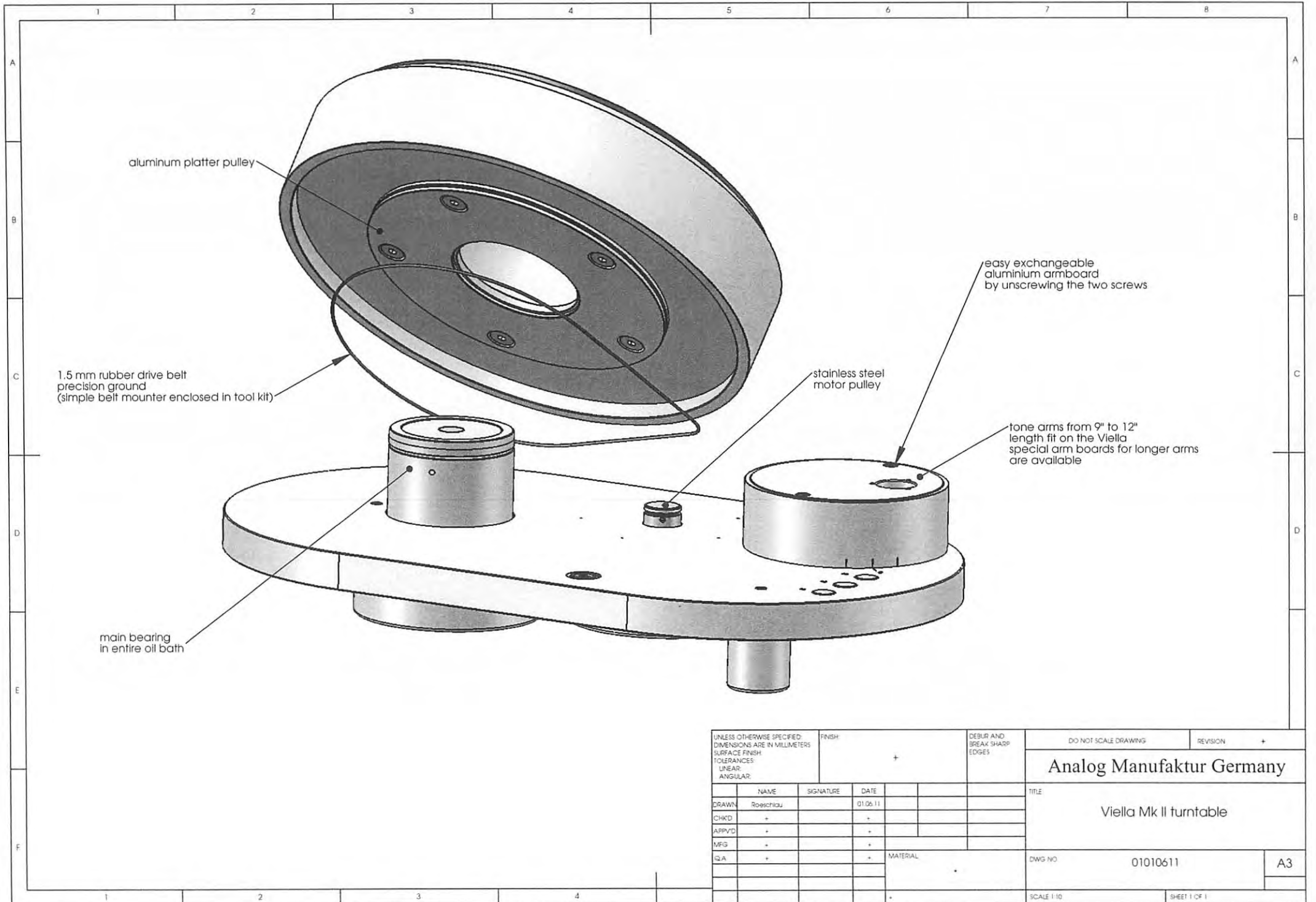

UNLESS OTHERWISE SPECIFIED: DIMENSIONS ARE IN MILLIMETERS SURFACE FINISH: TOLERANCES: LINEAR: ANGULAR:				FINISH: +		DEBUR AND BREAK SHARP EDGES		DO NOT SCALE DRAWING		REVISION +	
								<b>Analog Manufaktur Germany</b>			
								TITLE <b>Viella Mk II turntable</b>			
DRAWN Roeschlau		SIGNATURE		DATE 01.06.11				DWG NO 01010611		A3	
CHK'D +				+							
APP'VD +				+							
MFG +				+							
IQA +				+		MATERIAL					
								SCALE 1:10		SHEET 1 OF 1	



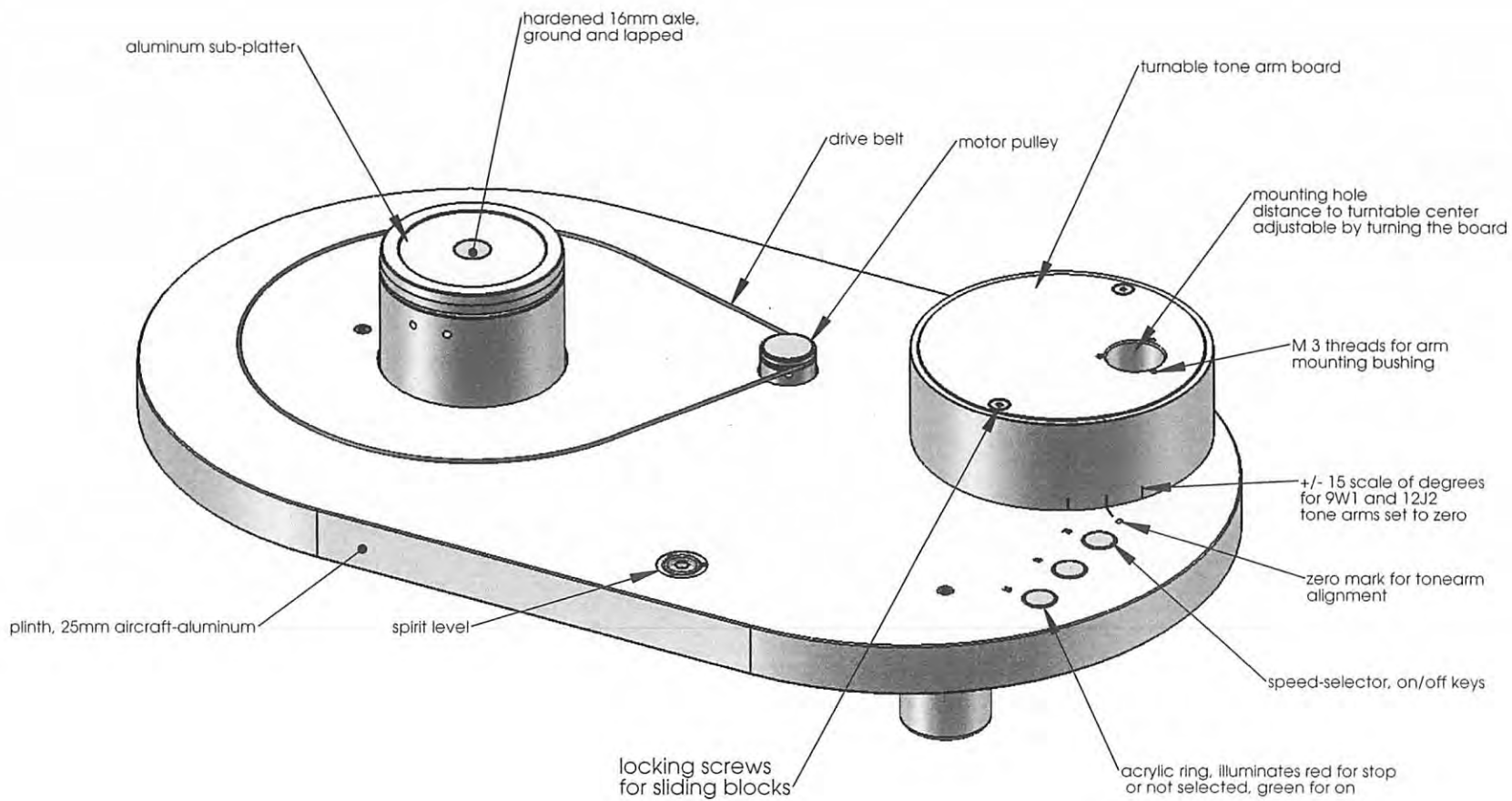

UNLESS OTHERWISE SPECIFIED: DIMENSIONS ARE IN MILLIMETERS SURFACE FINISH: TOLERANCES: LINEAR: ANGULAR:		FINISH +	DEBUR AND BREAK SHARP EDGES	DO NOT SCALE DRAWING	REVISION +
				Analog Manufaktur Germany	
				TITLE Viella turntable, front view	
DRAWN	Roerschold	SIGNATURE	DATE 20.02.11	DWG NO 02200211	A3
CHK'D	+				
APP'VD	+				
MFG	+				
Q.A	+				
				SCALE 1:2	SHEET 1 OF 1

access hole to spike screw #1  
hex screw driver #3

platter bearing,  
2 radial plain bearings with  
hydrodynamic lubrication,  
1 friction thrust bearing  
in oil bath

access hole to  
spike screw #3

option

access hole to spike screw #2

phono conector  
right channel

2mm ground socket

left channel

UNLESS OTHERWISE SPECIFIED: DIMENSIONS ARE IN MILLIMETERS SURFACE FINISH: TOLERANCES: LINEAR: ANGULAR:				FINISH:  +		DEBUR AND BREAK SHARP EDGES		DO NOT SCALE DRAWING		REVISION +	
								<b>Analog Manufaktur Germany</b>			
								TITLE:  Viella turntable rear view			
DRAWN	NAME	SIGNATURE	DATE					DWG NO		02190211	
CHK'D	-		19.02.11							A3	
APP'VD	-										
MFG	+										
QA	+					MATERIAL					
								SCALE:1:2		SHEET 1 OF 1	



**AMG**

**Tone arm 12J2**

**Operating and installation manual**

# Tone arm AMG 12J2

Dear music-lover,  
thank you for your vote of confidence by choosing the AMG tone arm for playing your records.

## Technical description

The tone arm 12J2 has been developed in a completely new patented principle of engineering. Starting out from a standard tone arm with horizontal and vertical axles and the bearing play caused by the principle of design, we have totally eliminated the play in the horizontal axis by replacing it with two 0.5 mm thick spring steel wires. This also enables a direct acoustic coupling which exactly draws from your record what is truly on it. This principle is also used in the rotor heads of helicopters replacing the standard bearings and their play.

The vertical axle is made of hardened tool steel and precision ground to a backlash-free fit with a needle roller bearing. The axles are maintenance free and never need to be adjusted.

The antiskating system is also integrated in the bearing case. In the upper rim of the arm shaft you see two M 1.6 hexagon socket screws. By loosening them you can move them up and down and adjust the antiskating force.

All materials we use are stainless steel, tool steel, spring steel, anodized aluminum in aircraft quality. The arm tube locking lever is plastic molded, the coupling attenuation sleeve in the counter weight is Teflon and the insert in the arm tube rest at the lift is of silicone.

## Preparation for installation

Take the tone arm out of the wooden box and place it on a soft rag on a level surface. Please check that the arm tube is locked by the locking lever. Insert the audio cartridge into the head shell to a preliminary position and slide the color coded female connectors on to the related pins at the cartridge. Now start with the final adjustment.

Effective length	304.8 millimeters
Distance from pivot to turntable center	291.4 mm
Overhang	13.4 mm
Offset Angle	17.89 degrees
Effective Mass	12.2 g
Null points	Inner 66.04 mm Outer 120.9 mm
Bore size for mounting bushing	25 mm
Screw-hole circle	30 mm

**Please be advised to tighten all screws at this precision engineered product at low torque and by a sensitive touch**

## Drilling the mounting bore

Please mark out as precise as possible the distance from pivot to turntable center of 291.4 mm. Drill a bore in your plinth or arm board at exactly this distance. You may use the mounting bushing as a template to drill the bores for the three fastening screws. The screws are metric M 3. For a wooden plinth use appropriate screws for wood.. Insert the mounting bushing so as the locking screw for the tone arm shaft is easy accessible from the right.

If you do not have a drill press or better a milling machine, please see a machine shop.

The 12J2 tone arm is available in three different variations concerning his connection.  
With a SME connector in the tone arm shaft were you may direct connect your audio cable  
With a SME connector in the tone arm shaft and a female SME connector you may make your own cable with.

With flying leads, which you have to solder to cinch or XLR connectors.

We also supply a cinch box made of solid aluminum and a pcb with two high quality cinch connectors and a 2 mm ground connector. If your turntable does not have connectors fit in.

### **Adjustment procedures**

Slide the tone arm with the shaft into the mounting bushing. If you got the version with the female connector in the bushing ( in combination with the Viella turntable ) be sure both connectors are matching before you push the arm shaft to the detent.

Slide the counterweight onto the arm tube and balance it, so the tube is horizontal and free swiveling. Be sure, to adjust the height so your cartridge clears the platter. The active range of the antiskating system is about 250 mm. Turn the arm shaft, that the cartridge is about 90 mm away from the platter. Take a # 1.5 hex screwdriver and lock the locking screw in the mounting bushing.

To continue, it is recommended to set the antiskating to minimum. In the flange of the arm shaft are left and right two screws. Take the # 1.5 hex screwdriver, loosen them a bit and slide them all the way down. This is what moves the antiskating magnetos away from the ring magneto in the bearing case. And your antiskating force is set to minimum.

Now adjust the vertical tracking force ( VTF ) with a scale. It is essential, that the arm tube is in a horizontal position while resting on the scale. If your scale sits much higher on the platter than a record, set it on a piece of wood aside the platter. When VTF is set, gently fasten the locking screw in the counter weight with the # 1.5 screwdriver.

The tone arm lift is preset at the factory. If you like to raise your stylus higher or lower, the lift slides in the bracket by loosening the locking screw in the bracket with the # 0.9 screwdriver.

Cross check your pivot to turntable center distance. If the tone arm is mounted to a Viella turntable, please check if the dial on the right side of the arm board is set to zero. This adjusts your distance correctly.

Now put a record on the platter and set the VTA until the spirit level in the arm hub shows horizontal. Assuming your turntable is set to horizontal.

Take the # 1.5 screwdriver, loosen the locking screw in the mounting bushing flange and if you have the two connectors with a Viella turntable, loosen the connector locking screw in the arm board as well. Adjust the VTA with the height adjustment screw in the lift bracket. Tighten the locking screw(s) again.

Now set the correct overhang by using a good template.

The antiskating system is very effective. To start with leave the left hand magneto in the lowest position and bring your right hand magneto up by two thirds with the # 1.5 screwdriver.. Than continue with a measuring record or Wally Tools Wallyskater or something equivalent.

The tone arm also has a azimuth adjustment. It is set to zero at the factory. If you do not have appropriate measuring equipment, like a Fosgate Fosgometer, it is not recommended to use it. If you like to make azimuth adjustments, take the # 1.5 screwdriver loosen the locking screw at the left side of the tube hub. Then adjust the azimuth by little increments with the screw on top of the hub. Press the hub gently down by your finger while tightening the locking screw again.

Now enjoy your music. We like to wish you lots of joy with this precision product.

Werner Röschlau

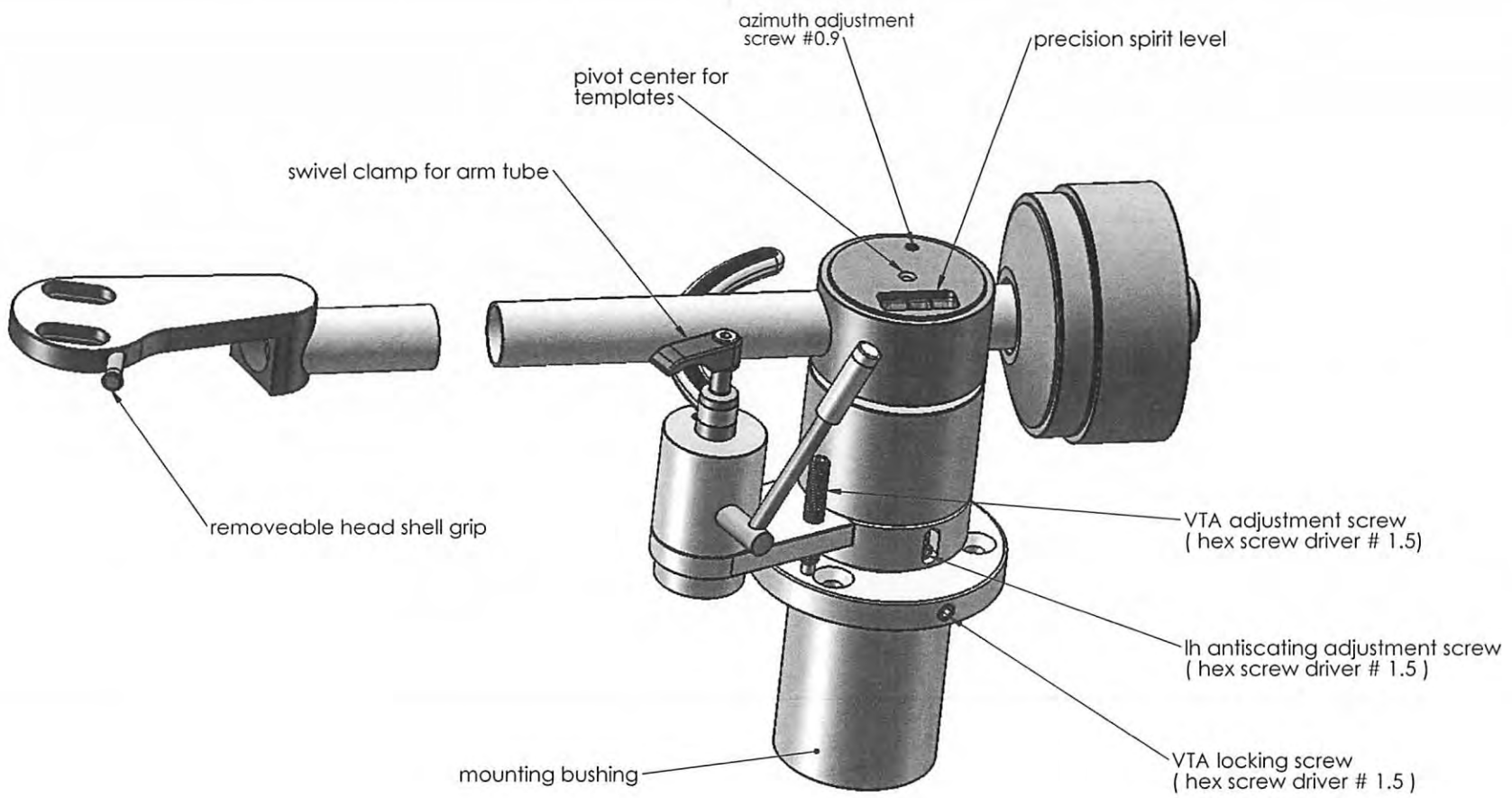

UNLESS OTHERWISE SPECIFIED:  
 DIMENSIONS ARE IN MILLIMETERS  
 SURFACE FINISH:  
 TOLERANCES:  
 LINEAR:  
 ANGULAR:

FINISH:

DEBUR AND  
 BREAK SHARP  
 EDGES

DO NOT SCALE DRAWING

REVISION

Analog Manufaktur Germany

	NAME	SIGNATURE	DATE
DRAWN	Roeschlau		16.03.11
CHK'D	-		
APP'VD	-		
MFG	-		
Q.A	-		

MATERIAL:

TITLE:

Tonearm 12J2

DWG NO.

01160311

A4

SCALE:1:1

SHEET 1 OF 1

1 2 3 4 5 6

A

B

C

D

A

B

C

D

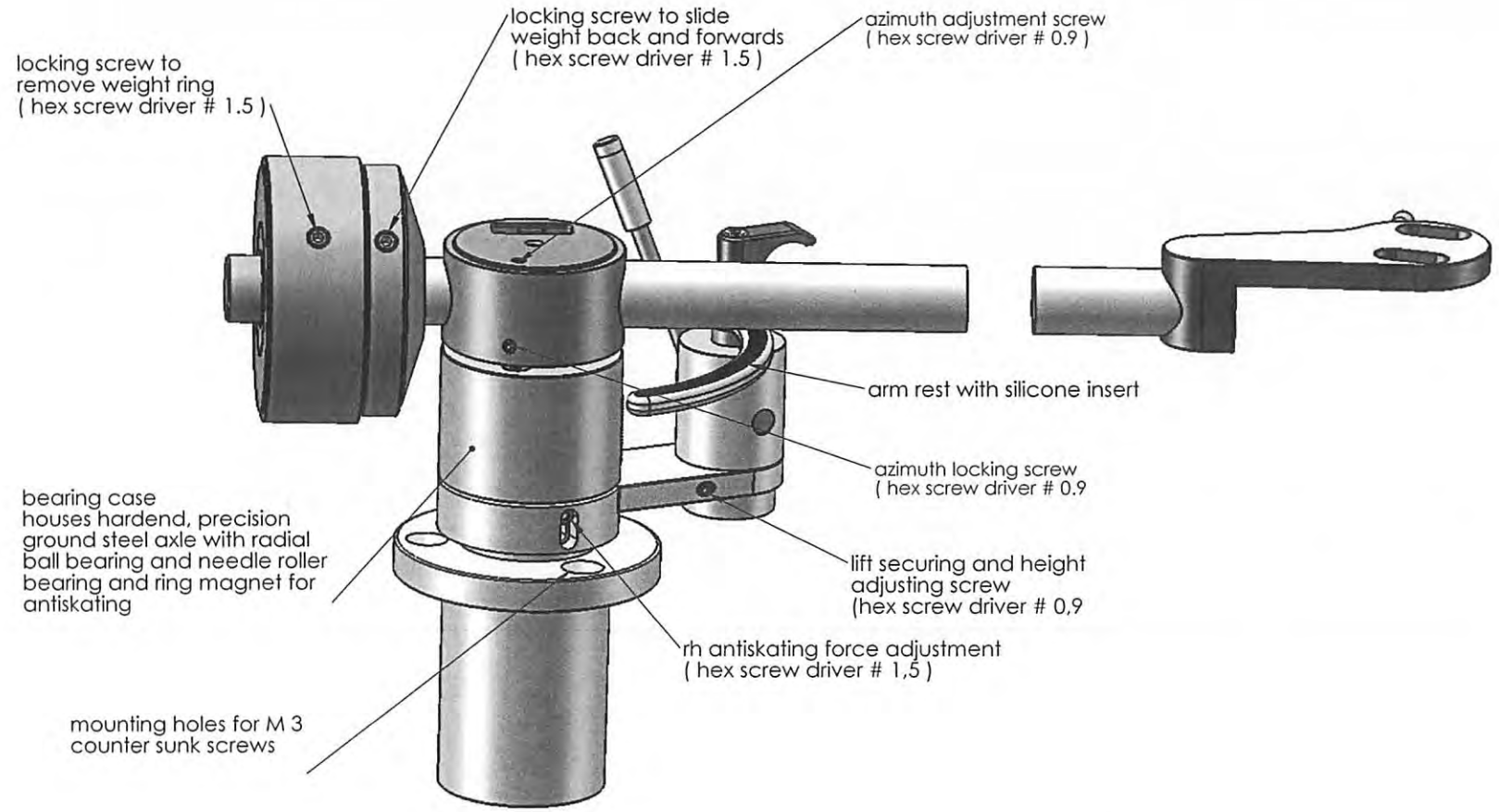

UNLESS OTHERWISE SPECIFIED:  
 DIMENSIONS ARE IN MILLIMETERS  
 SURFACE FINISH:  
 TOLERANCES:  
 LINEAR:  
 ANGULAR:

FINISH:

DEBUR AND  
 BREAK SHARP  
 EDGES

DO NOT SCALE DRAWING

REVISION

Analog Manufaktur Germany

	NAME	SIGNATURE	DATE
DRAWN	Röschlau		16.03.11
CHK'D	.	.	.
APPV'D	.	.	.
MFG	.	.	.
Q.A	.	.	.

TITLE:

Tonearm 12J2

DWG NO.

02160311

SCALE:1:1

SHEET 1 OF 1

A4

1

2