

PLEASE READ this sheet prior to assembly to familiarise yourself with the various stages of construction. Carefully open the pack supplied and check the contents against the parts and fittings check list.

Do not destroy any of the packaging until you are certain that you have all the necessary parts for the assembly.

Please ensure that the packaging is disposed of in a safe environmentally friendly way.

**CAUTION:** There are small components used in the construction of this unit. These loose items should be kept away from young children during assembly, to avoid the danger of choking.

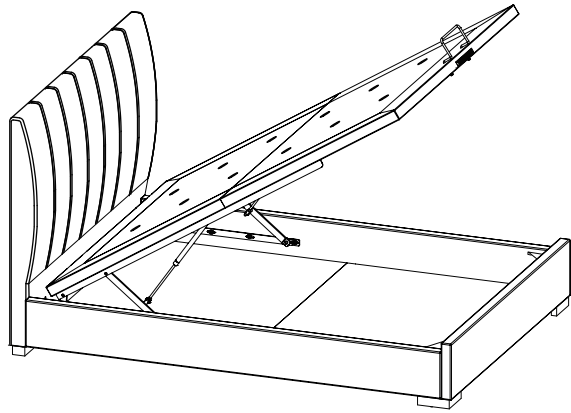

**IMPORTANT: BEFORE STARTING TO ASSEMBLE THE BED - PLEASE READ THESE INSTRUCTIONS CAREFULLY.**

### Parts Identification

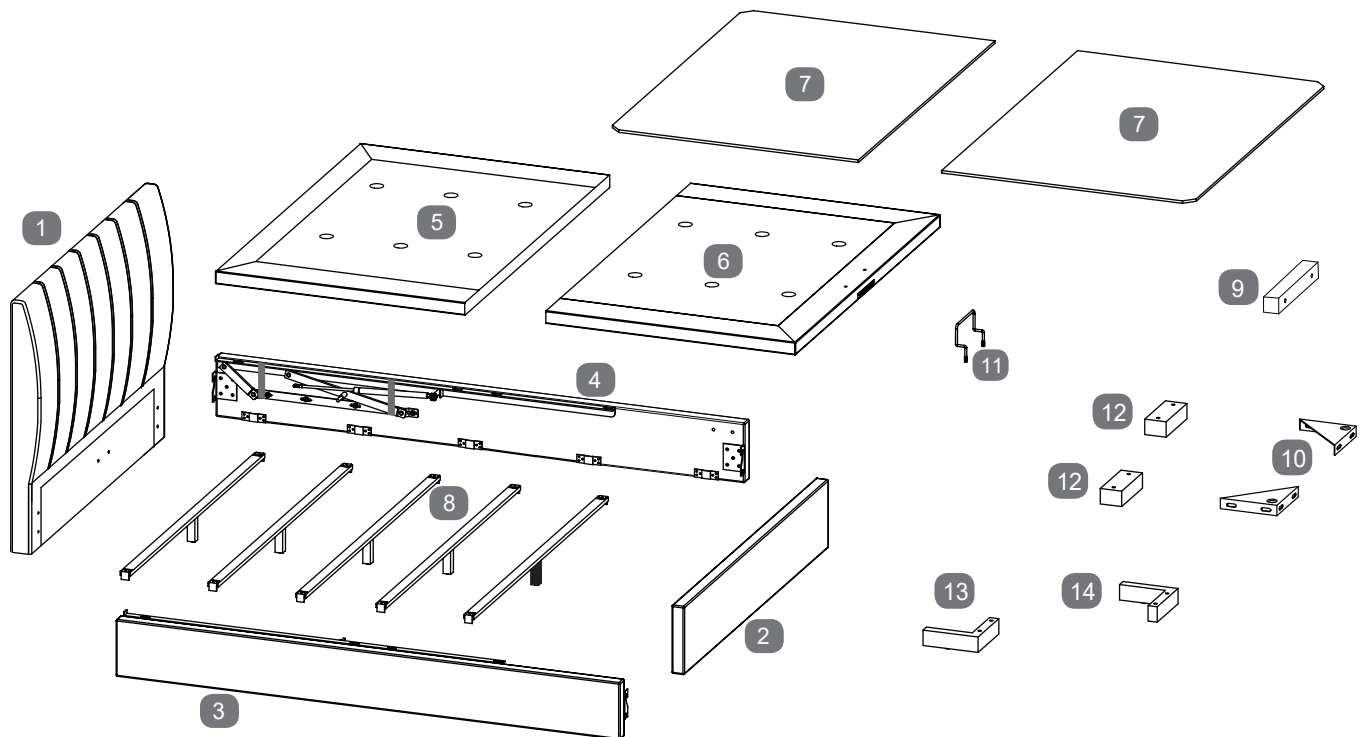

### Parts Checklist

Ref.	Description	Qty	Ref.	Description	Qty
1	Headboard	1	8	Base Board Support Rails (Wood)	5
2	Footboard	1	9	Mattress Base Support Rails	2
3	Side Rail - Left	1	10	Corner Brackets	2
4	Side Rail - Right	1	11	Mattress Base Lifting Handle	1
5	Mattress Base Board - Headend	1	12	Feet for Headboard	2
6	Mattress Base Board - Footend	1	13	Feet for Footboard LH	1
7	Storage Base Boards	2	14	Feet for Footboard RH	1

# Fittings Checklist

## HARDWARE NEEDED FOR BED ASSEMBLY (PACK A)

Code	Description	Qty	Code	Description	Qty
A	Bolts (M8x30mm) for fitting corner brackets (10) to footboard (2) and side rails (3&4) and also fitting side rails to headboard & footboard (1&2).	x16	D	Allen Key (for M8 bolt)	x1
B	Spring Washers (for M8 bolts)	x16	H	Bolts (M8x45mm) for fitting feet (12,13&14) to headboard & footboard (1&2)	x8
C	Flat Washers (for M8 bolts)	x28	K	Bolts (M8x60mm) for fitting mattress base support rail (9) to headboard & footboard (1&2)	x4

## HARDWARE FOR FITTING MATTRESS BASE BOARDS (PACK B)

Code	Description	Qty	Code	Description	Qty
A	Bolts (M8x30mm) for fitting gas-lift mechanism and metal connecting plates (J) to mattress base boards (5&6).	x16	F	Spanner (for M8 nuts)	x1
B	Spring Washers (for M8 bolts)	x12	G	Flange Lock-Nuts (M8) for gas-lift pistons.	x2
C	Flat Washers (for M8 bolts)	x16	J	Metal Plates for connecting mattress base boards (5&6)	x2
E	Black domed nuts (M8) for fitting mattress base lifting handle (11) to mattress base board (6).	x2	L	Flat Washers (Black)	x4

**Please Note: Domed Nuts 'E' & Flat Washers 'L' are pre-fitted to Lifting Handle (Part 11)**

### Additional Tools Required

No Additional Tools Required

### Care & Maintenance

In the unlikely event of missing or damaged parts, please contact your retailer. Please have this guide at hand quoting the part code reference numbers shown when requesting spare or replacement parts.

### General Hints & Tips



Please retain your assembly instruction and tools provided for future use. Periodically check that all bolts are still tight.

Assembly requires two persons.





1.5 Hrs

Approximate time to assemble this product



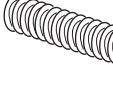

# Bed Assembly - Use Pack 'A'

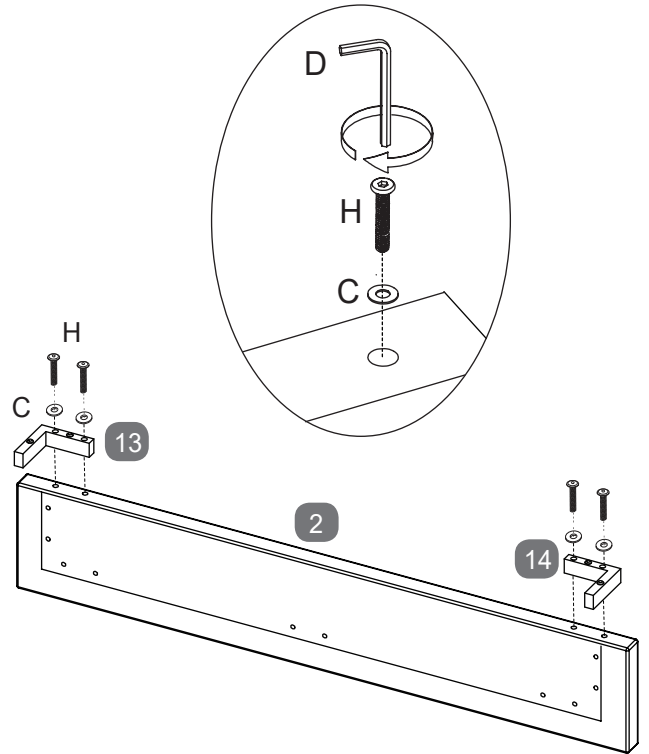
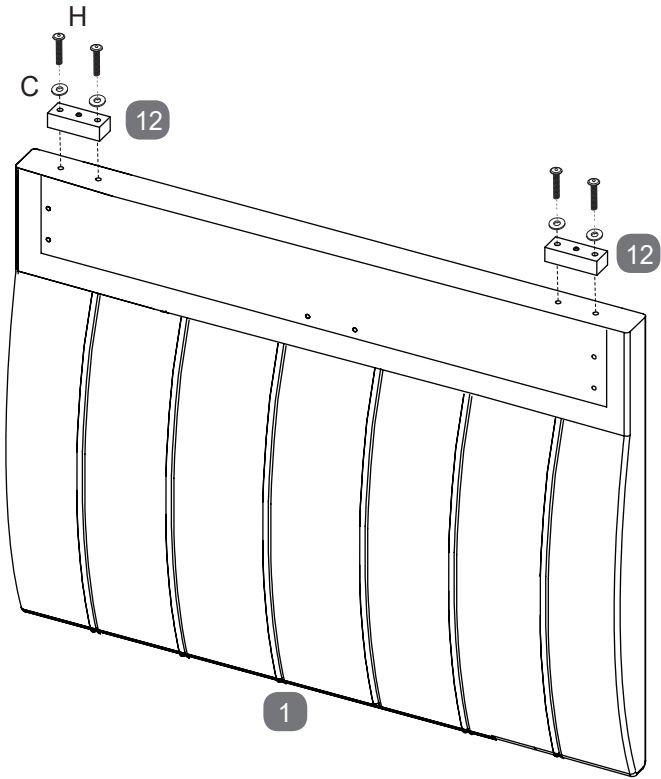
## Stage 1

- C  x8
- D  x1
- H  x8

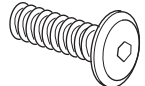

## Stage 2

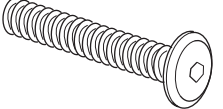
- A  x8
- B  x8
- C  x12
- D  x1
- K  x4

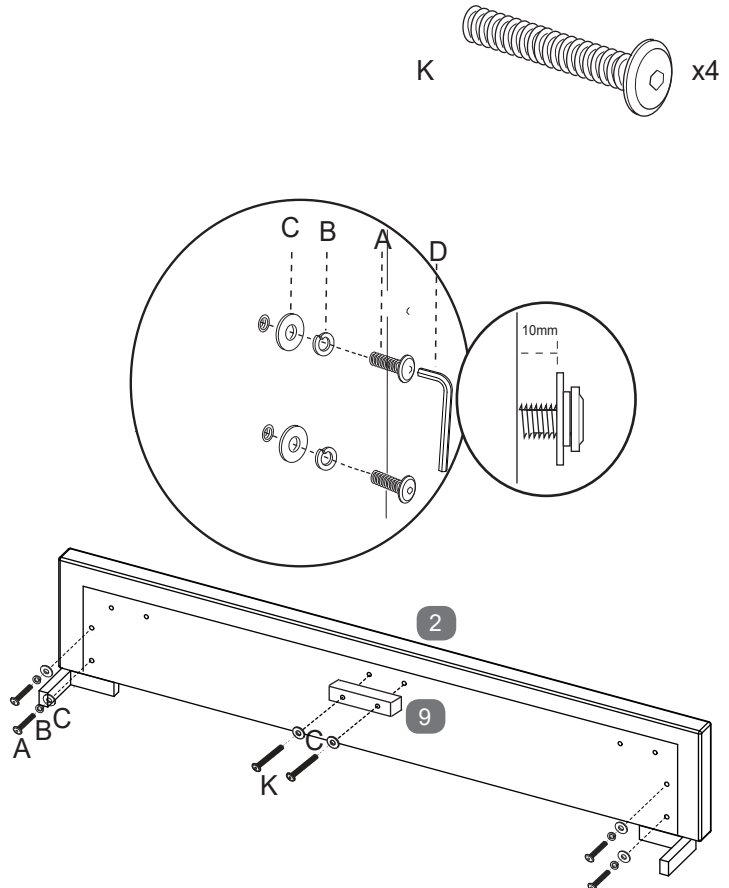
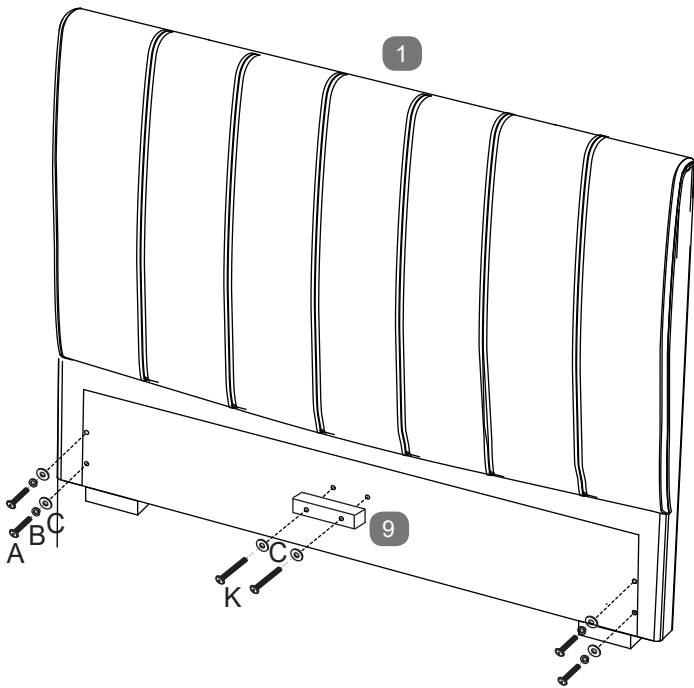

# Bed Assembly - Use Pack 'A'

Stage  
3

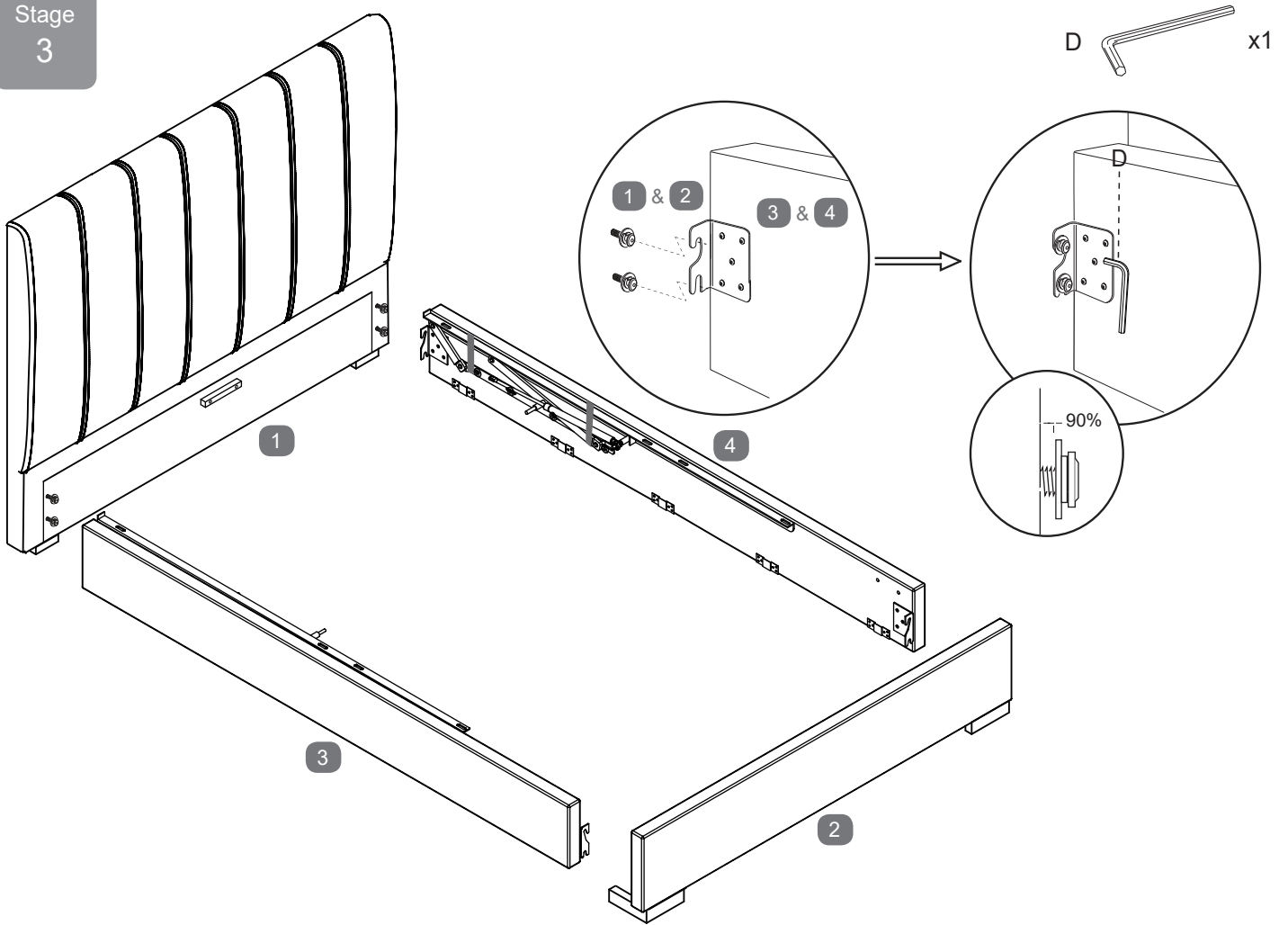

Stage  
4

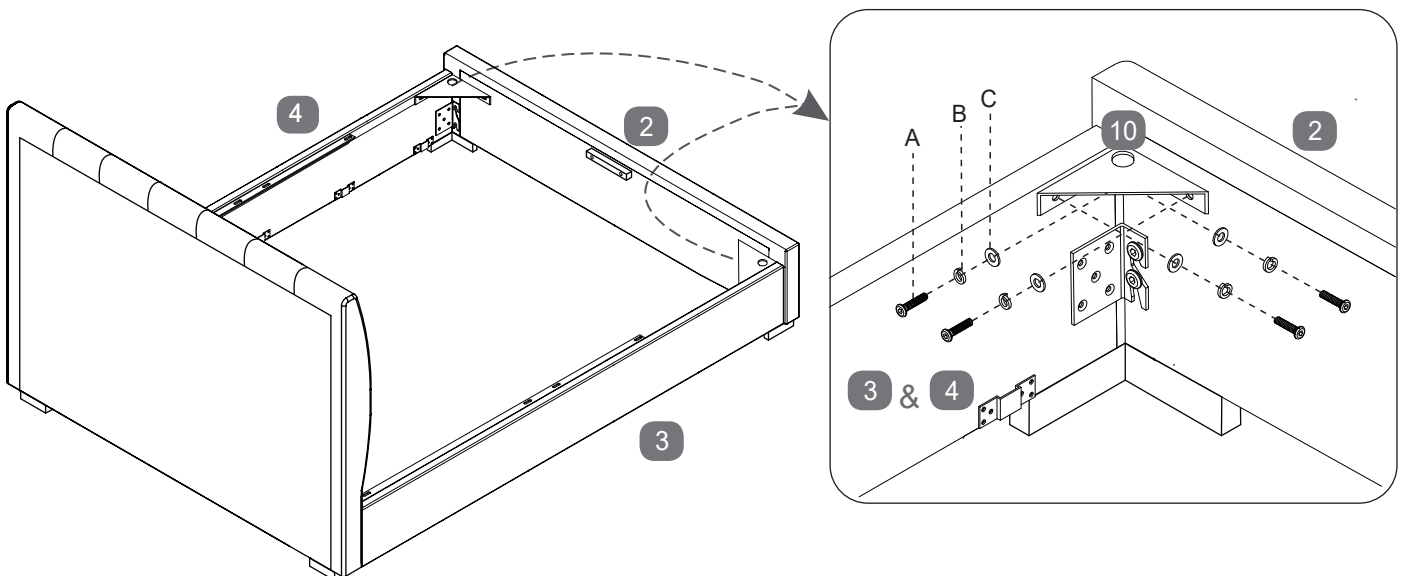

DO NOT TIGHTEN BOLTS YET

# Base Board Assembly

Stage  
5

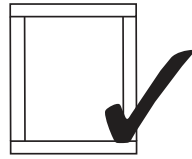
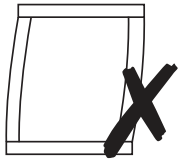
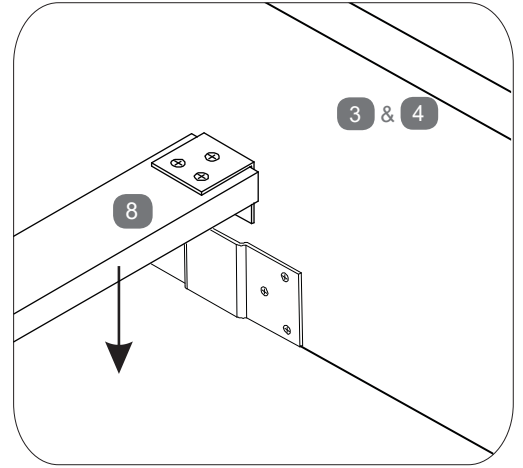
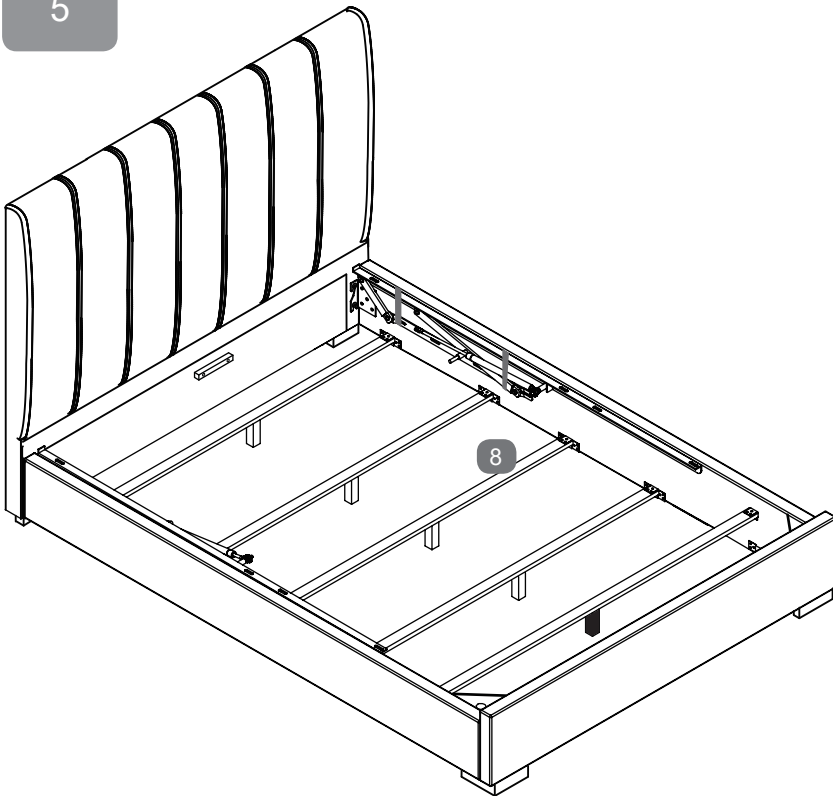

Carefully fit the wooden storage base board support rails being careful not to damage the fabric on the internal face of the side rails. Make certain the bed is squared up as shown in the diagram then tighten all bed assembly bolts 100%.

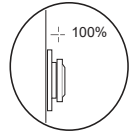

Stage  
6

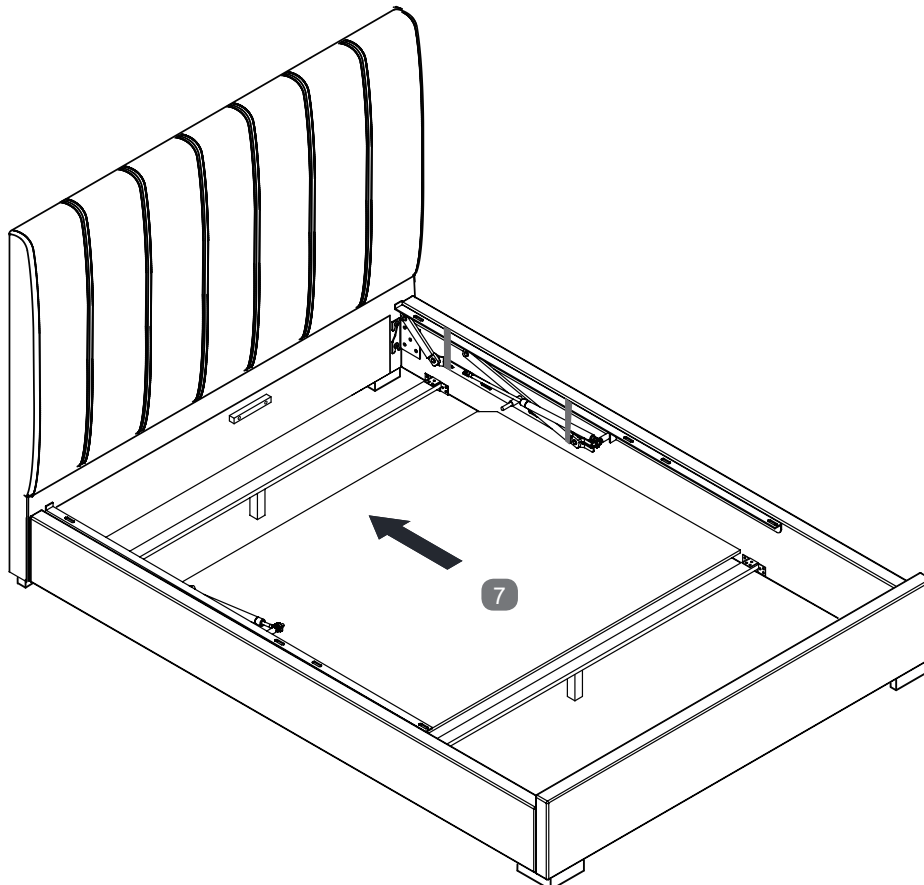

7

# Gas Lift Assembly

Stage  
7

i) Untie the two mechanisms.

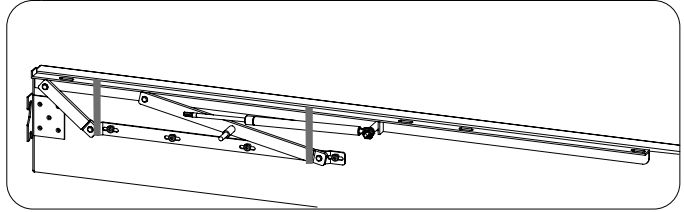

ii) Lift up mattress base board support bars.

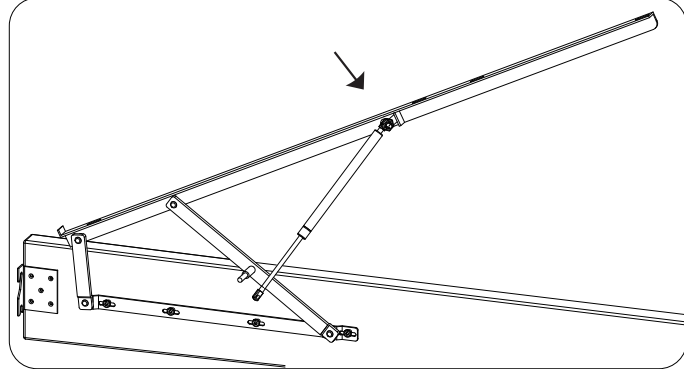

iii) Connect the piston stems

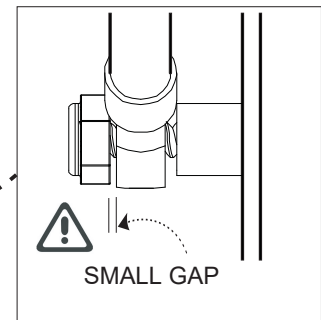
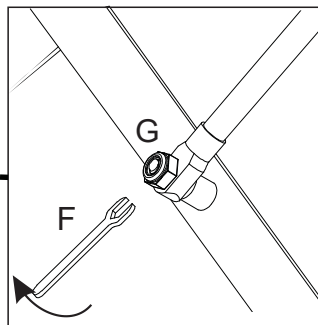
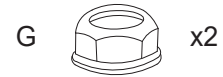
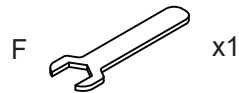
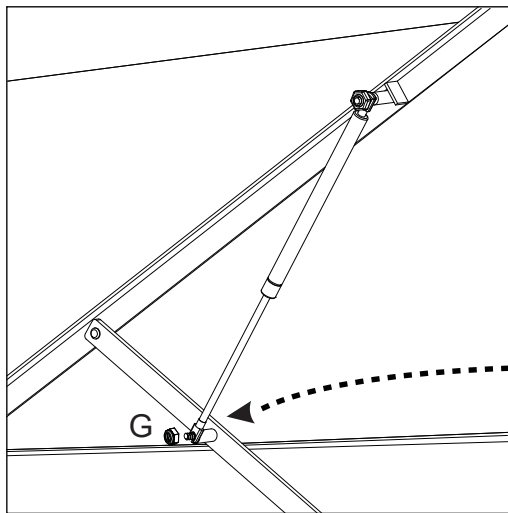

Hold up each arm and slide piston stem onto the threaded axle and fit loc-nut (G) using spanner (F).

**Note, do not over-tighten - a small gap needs to be left - see sketch.**

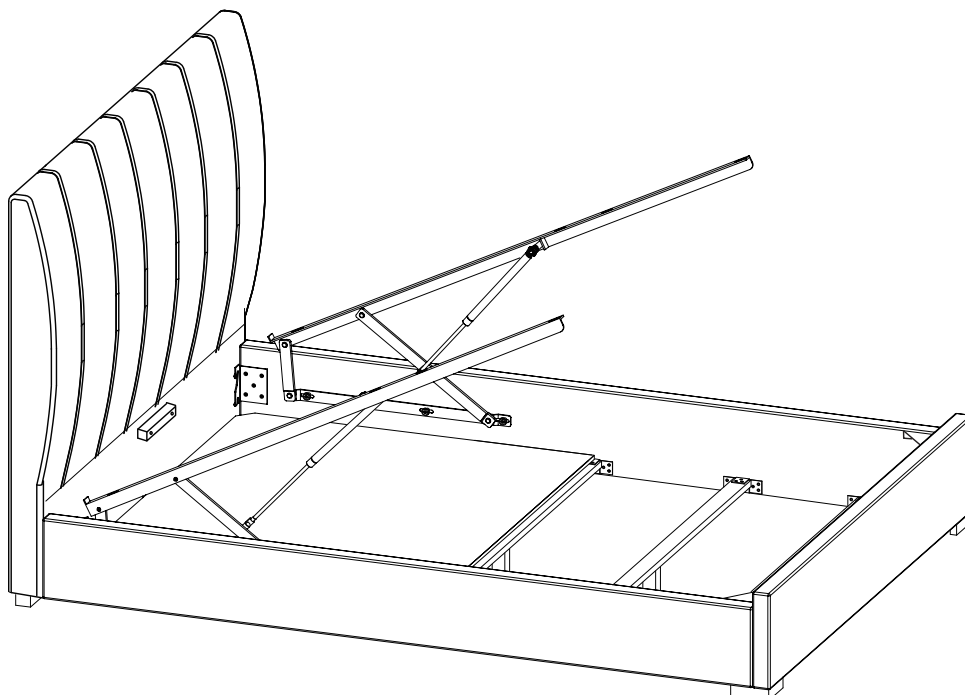

# Mattress Base Assembly - Use Pack 'B'

Stage  
8

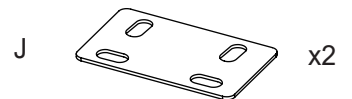
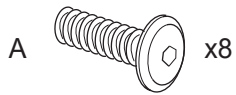

SLIDE HEADEND MATTRESS BASE BOARD (5)  
UP AGAINST THE LIFTING ARM STOP PLATES.

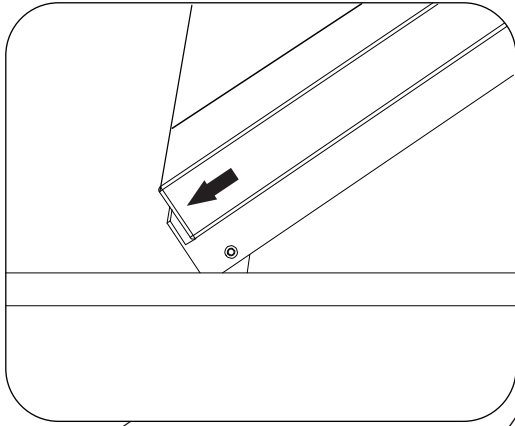

CAREFULLY SCREW x4 BOLT SETS INTO BASE  
BOARD AS SHOWN - DO NOT TIGHTEN 100% YET.

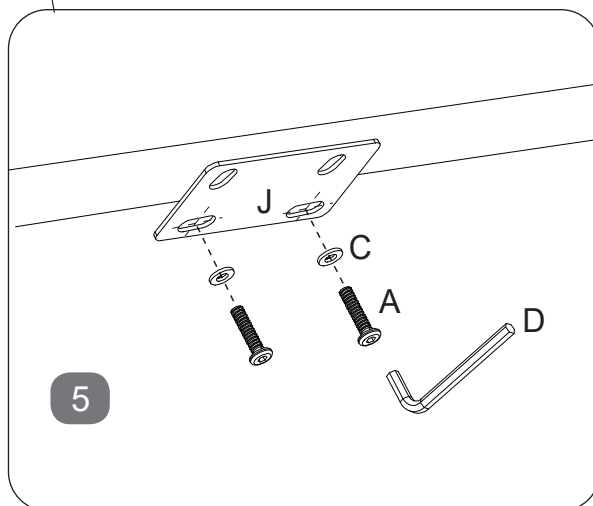
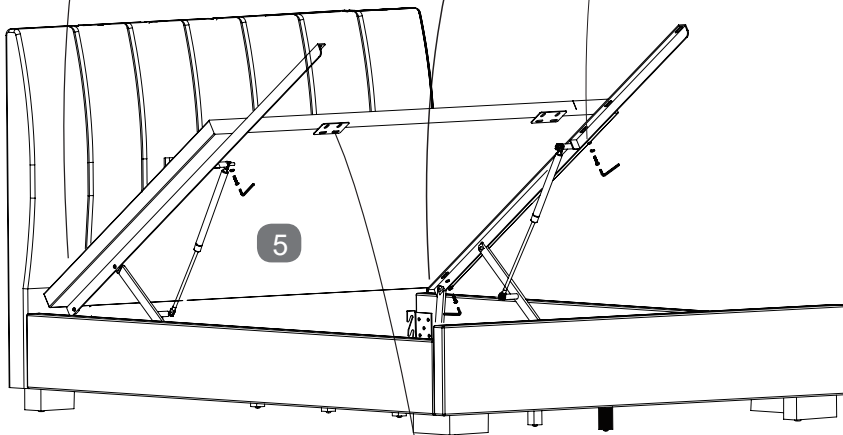
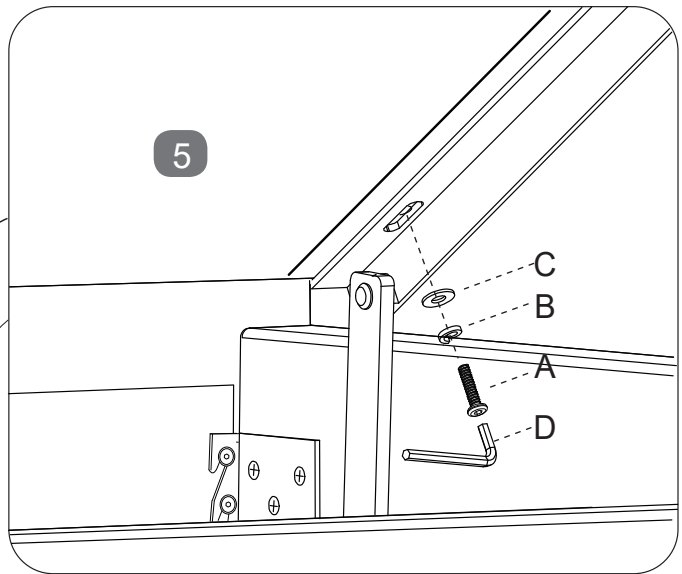

BEFORE FITTING FOOTEND BASE BOARD (6) FIT BOTH PLATES (J) TO HEADEND BASE BOARD (5) AS SHOWN

# Mattress Base Assembly - Use Pack 'B'

Stage  
9

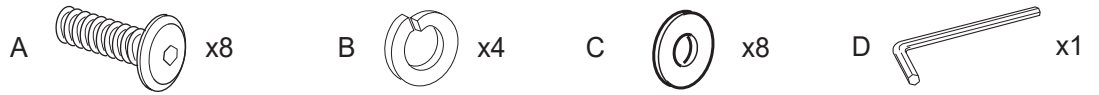

SLIDE FOOTEND MATTRESS BASE BOARD (6) INTO POSITION

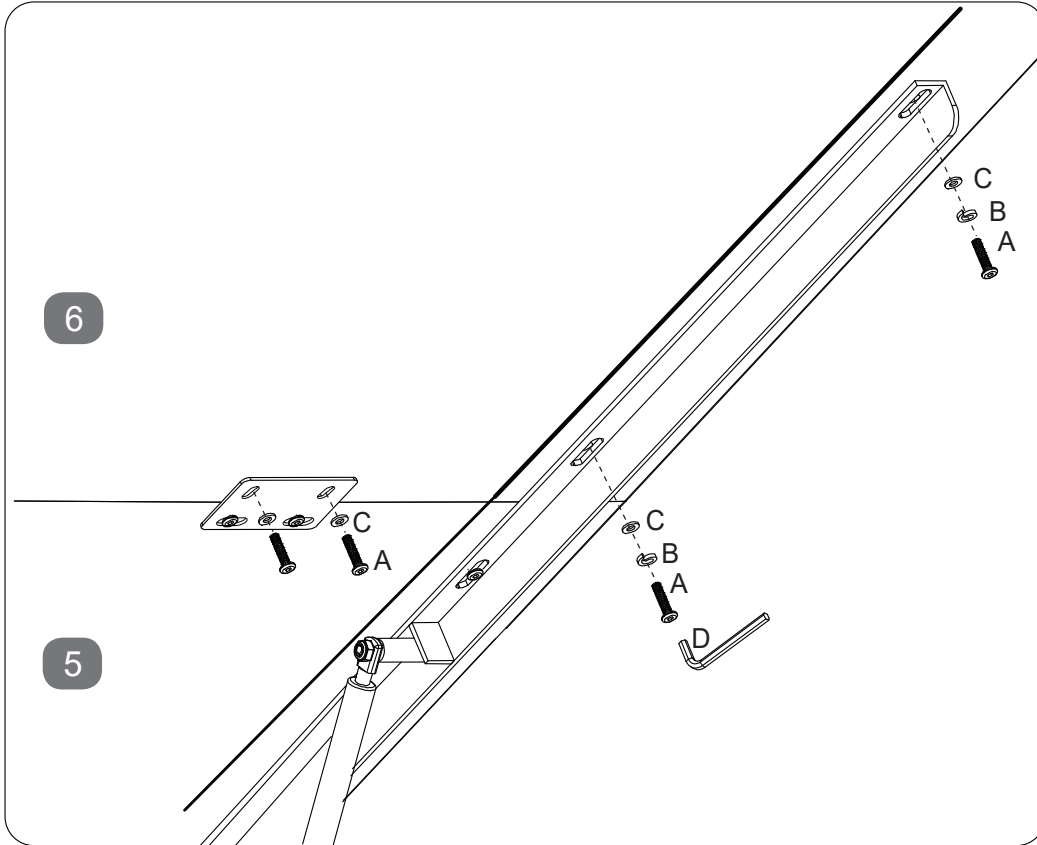

LOOSELY CONNECT (6) TO THE PLATES THEN SCREW OTHER x4 SETS OF BOLTS INTO PLACE

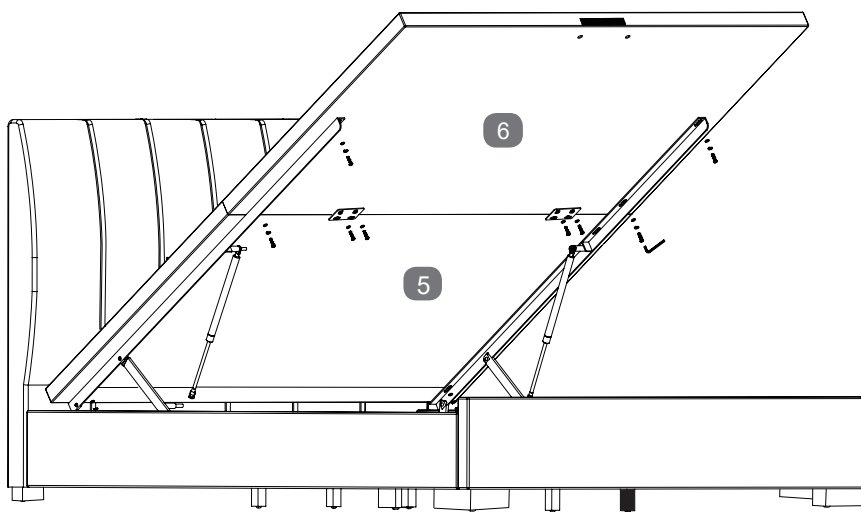

WHEN ALL x16 BOLT SETS ARE IN PLACE, MAKE SURE SIDES OF BASE BOARDS ARE IN LINE WITH EACH OTHER, THEN TIGHTEN ALL BOLTS 100%

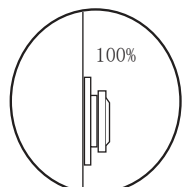



## Base Board Assembly

Stage  
10

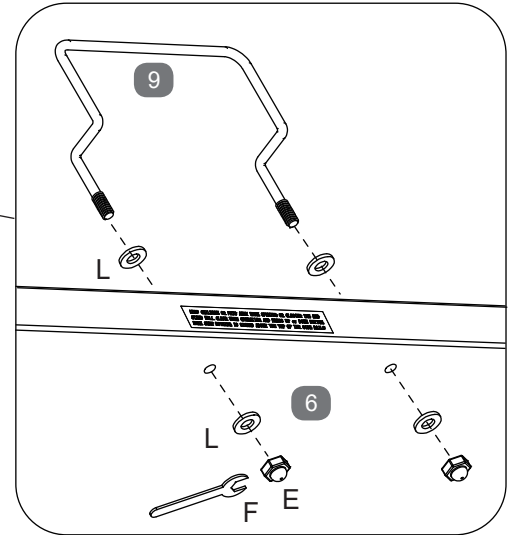
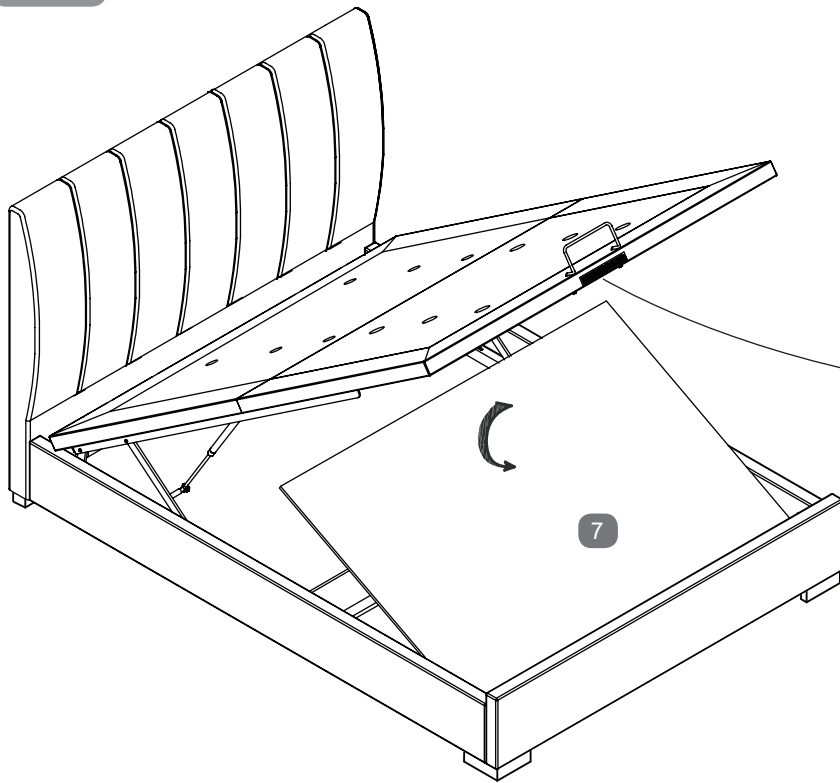
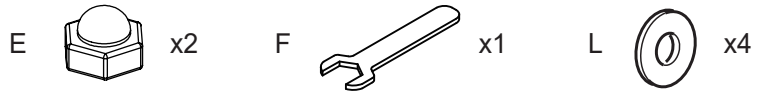

## Warning.!

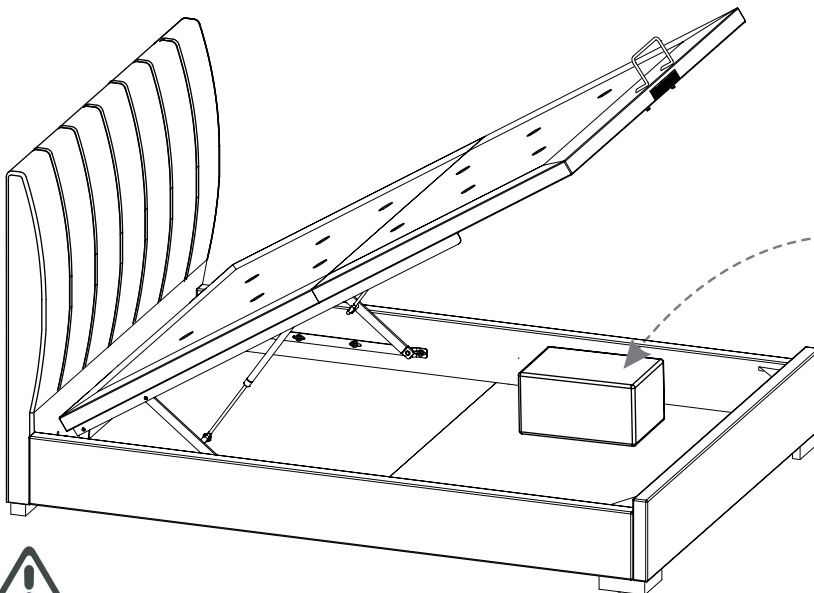

**Note:** Be very careful what you store under the bed - the top of an item, like a suitcase or a box, must not touch the underside of the mattress base or it may get damaged.  
Maximum item height is 210mm.



**NOTE:** Before fitting the mattress on top of the mattress base, carefully lower the base holding the handle firmly and if necessary hold base horizontal, then place mattress on top. Be careful, without a mattress in place the base may lift on its own and speed of movement is quick and may cause injury.

Depending on the weight of the mattress, the raising & lowering speed will vary so be careful until you get used to the speed. Always use the handle to lift or lower the frame - keep fingers well away from the moving parts.

**When fully assembled and with the mattress in position, please raise & lower the ottoman 4/5 times to ensure the gas pistons are fully lubricated.**