

# ASSEMBLY INSTRUCTION FOR N-WC-OTO-BT-45-748-BW-75"

**Note:**

- Read instructions carefully.
- Carefully identify each component especially those that are similar.
- Separate and identify each component from the hardware pack and rest each one in its proper location before fastening
- Do not over tighten the screws or bolts when assembling.



**TOOL REQUIRED**

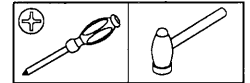

## Step 1

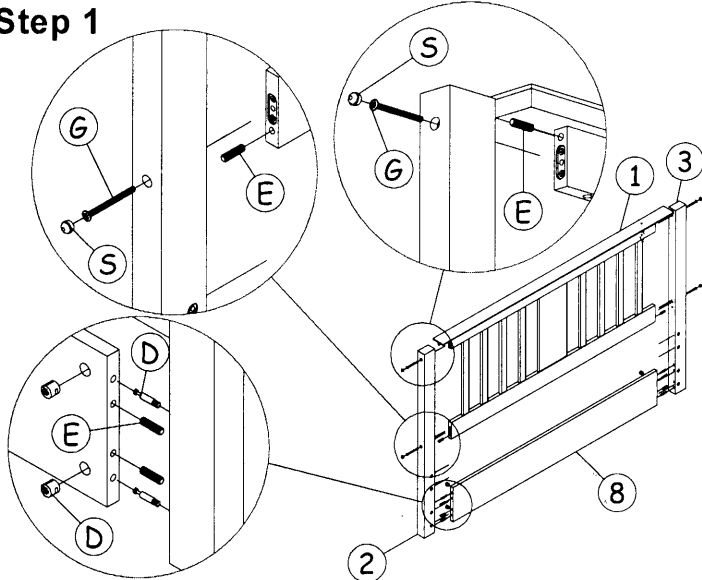

Fix all headboard component as shown

## Step 2

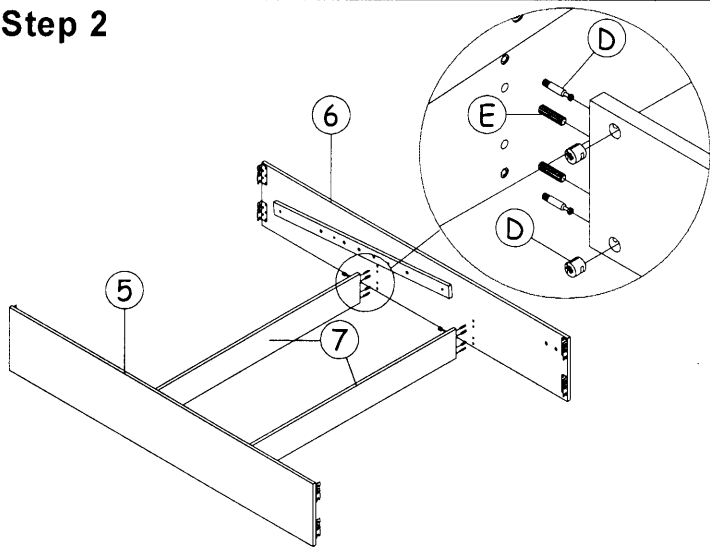

Assemble the left & right side rails to the center wood panel with minifix screws as shown.

## Step 3

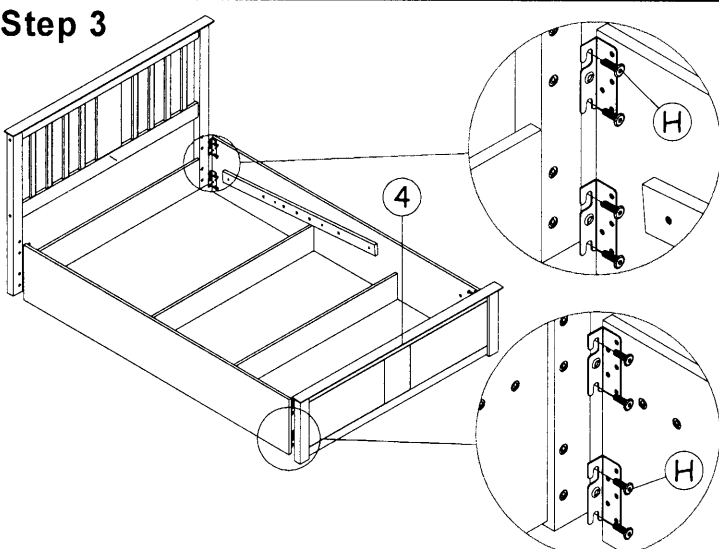

Fix side rails to the headboard and footboard with bolts 'H' as shown.

## Step 4

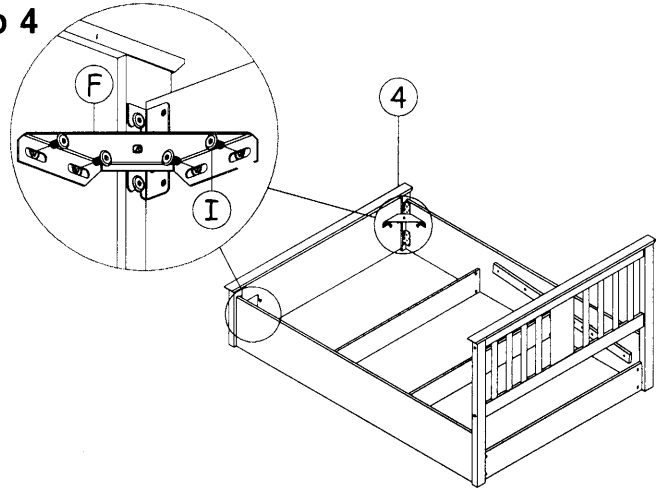

Fix metal corner block 'F' to the edge of footboard and side rails with bolts 'I' as shown.

## Step 5

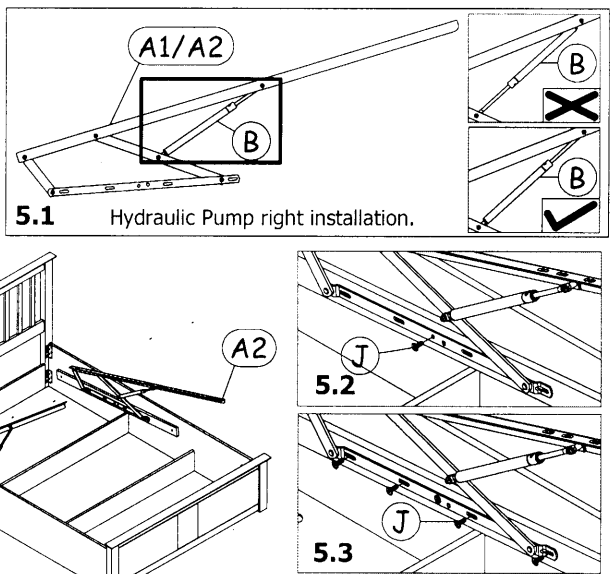

Firstly, fix the hydraulic pump to each hydraulic base as shown in diagram 5.1. Next, fix the left & right hydraulic support to the both side rails. Then, fix bolts 'J' first as shown in diagram 5.2 and do not tighten yet. Finally, fix all bolts and tighten as shown in diagram 5.3.

## Step 6

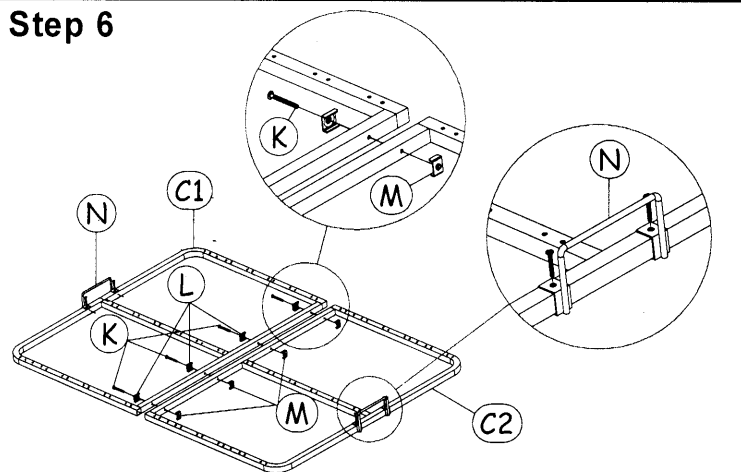

Assemble front & back frames bed base with bolts 'K' and fix base handles to the bed base with bolts 'O' as shown.

Please follow our assembly instruction procedure for easier assemble.

### Step 7

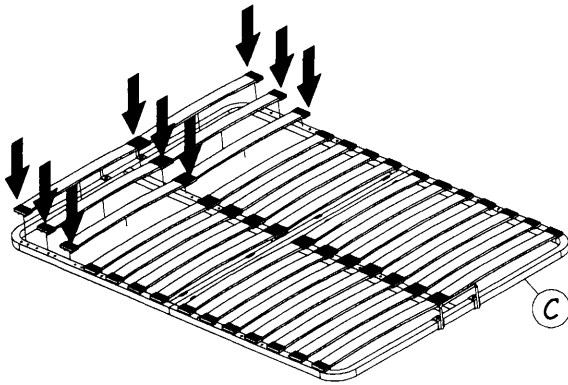
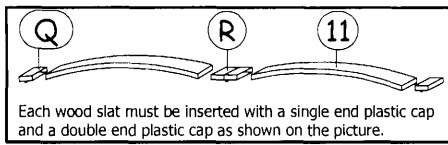

Place wood slats with plastic caps as above drawing. Then, fix it on the bed base by pressing it accordingly to the default holes. Ensure the plastic cap's pin is aimed to the hole.

### Step 8

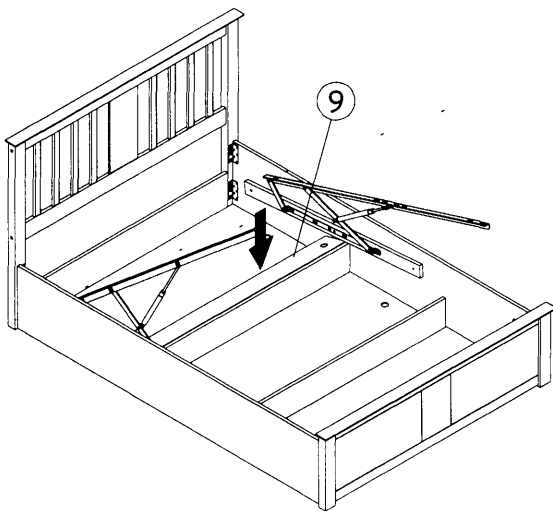
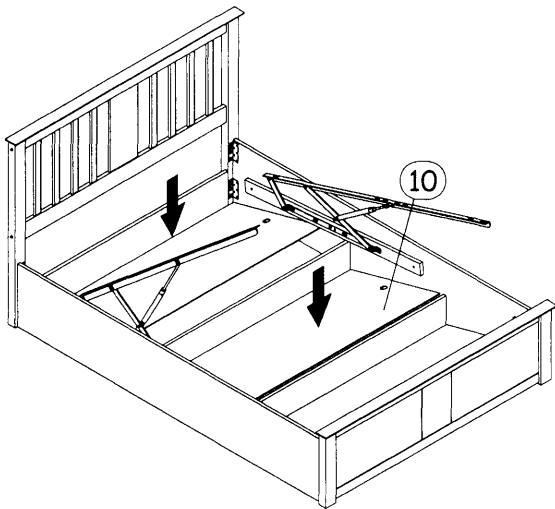

Place panels '9' & '10' as shown.

### Step 9

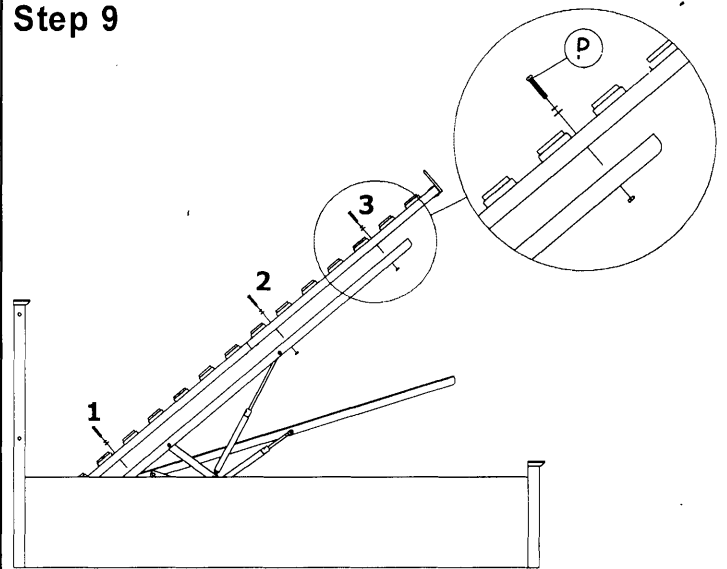

Assemble the bed base on the right & left hydraulic frame and fix bolts starting from '1' to '3' as shown. Important note : Do not tighten the bolts yet!

### Step 10

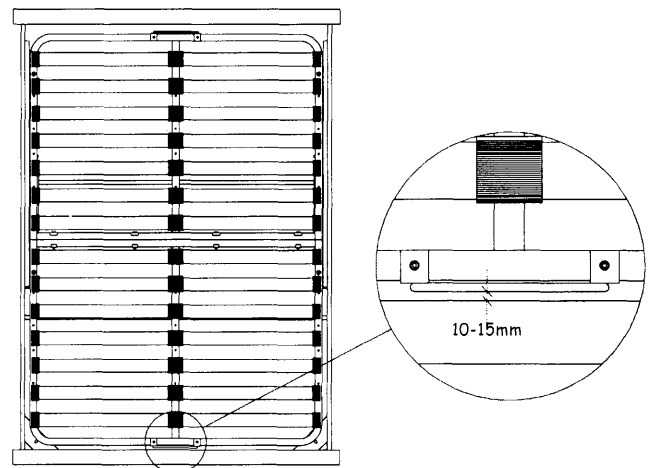





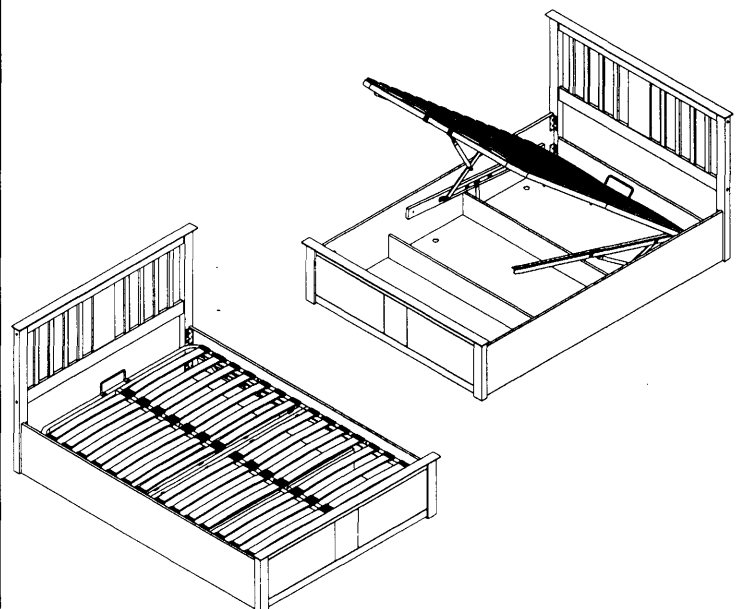

Adjust the bed base, make sure distance with the front footboard approximately 10 -15mm gap as shown. Important note : Tighten all screws.

**THE BED HAS BEEN FULLY ASSEMBLED**

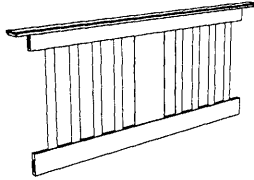

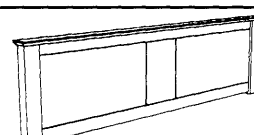
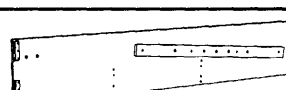
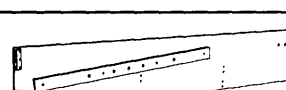
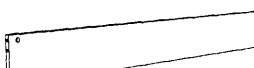



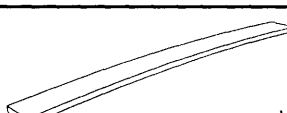

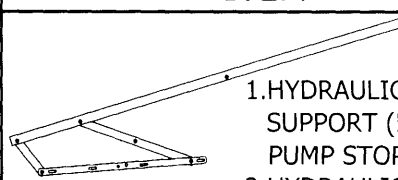
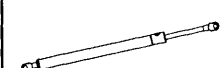

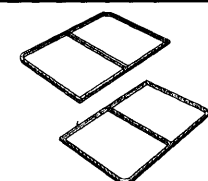









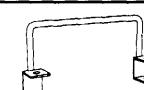

Please follow our assembly instruction procedure for easier assemble.

# PARTS & HARDWARE LIST N-WC-OTO-BT-45-748-BW-75"

PART LIST		
NO.	ITEM	QTY.
1	 HEADBOARD FRAME 1 PC	1 PC
2	 WOOD POST (L) 1 PC	1 PC
3	 WOOD POST (R) 1 PC	1 PC
4	 FOOTBOARD 1 PC	1 PC
5	 SIDE RAIL (L) 1 PC	1 PC
6	 SIDE RAIL (R) 1 PC	1 PC
7	 CENTER WOOD PANEL 2 PCS	2 PCS
8	 BACK WOOD PANEL 1 PC	1 PC
9	 SMALL BASE PANEL 1 PC	1 PC
10	 BIG BASE PANEL 3 PCS	3 PCS
11	 WOOD SLAT 28 PCS	28 PCS

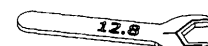
HARDWARE LIST		
NO.	ITEM	QTY
A	 1. HYDRAULIC BASE SUPPORT (L) c/w PUMP STOPPER 2. HYDRAULIC BASE SUPPORT (R) 1 PC 1 PC	1 PC 1 PC
B	 HYDRAULIC PUMP 2 PCS	2 PCS

NO.	ITEM	QTY.
C	 1. BED BASE (B) (1 x HOLE MOUNTING) 2. BED BASE (F) (2 x HOLE MOUNTING) 1 PC 1 PC	1 PC 1 PC
D	 MINI FIX BOLD 12 PCS	12 PCS
E	 WOOD DOWEL 8 x 30 16 PCS	16 PCS
F	 ML-CB (METAL CORNER BLOCK) 2 PCS	2 PCS
G	 JCBC BOLT M6 x 70MM 4 PCS	4 PCS
H	 JCBC BOLT M8 x 25MM 16 PCS	16 PCS
I	 JCBC BOLT M8 x 15MM 8 PCS	8 PCS
J	 JCBC BOLT M8 x 20MM 10 PCS	10 PCS
K	 JCBC BOLT M8 x 75MM 4 PCS	4 PCS
L	 FLAT WASHER M8 4 PCS	4 PCS
M	 BASE NUT 4 PCS	4 PCS
N	 BASE HANDLE 2 PCS	2 PCS
O	 JCBC BOLT M6 x 40MM 4 PCS	4 PCS
P	 M8 x 40MM RH BOLT c/w HEX NUT, SPRING & FLAT WASHER 6 PCS	6 PCS
Q	 SINGLE END PLASTIC CAP 28 PCS	28 PCS
R	 DOUBLE SIDE END PLASTIC END 14 PCS	14 PCS
S	 WOOD BUTTON 4 PCS	4 PCS
	 ALLEN KEY - M6 1 PC	1 PC
	 ALLEN KEY - M8 1 PC	1 PC
	 M12.8 SPANAR 1 PC	1 PC
	 M14 SPANAR 1 PC	1 PC

\*CAUTION : KEEP ALL HARDWARE PARTS OUT OF REACH OF CHILDREN\*

## " IMPORTANT NOTE "

WHEN THE BED IS BUILT AND THE MATTRESS FRAME IS AT 45 DEGREE  
PLEASE PLACE THE MATTRESS ON THE BED.  
PLEASE NOTE THAT THE WEIGHT OF THE MATTRESS IS REQUIRED TO  
HELP CLOSE THE BED.  
TO LOWER THE SLEEPING PLATFORM STAND AT THE FOOT END OF THE  
BED AND PUSH SHARPLY  
DOWNWARDS USING BOTH HANDS.

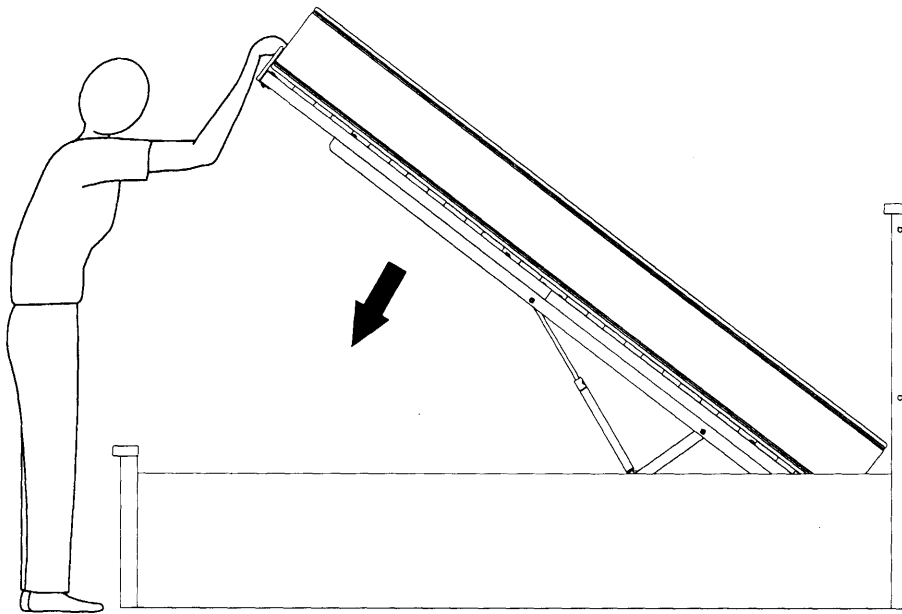

# CAUTION :

PLEASE USE HYDRAULIC PUMP STOPPER FOR SAFETY PURPOSE.

