

ASSEMBLY INSTRUCTION FOR 45-7422L-EM-MSR-75

Note:
 • Read instructions carefully.
 • Carefully identify each component especially those that are similar.
 • Separate and identify each component from the hardware pack and rest each one in its proper location before fastening.
 • Do not over tighten the screws or bolts when assembling.

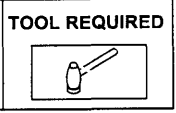

Step 1

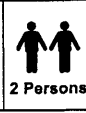
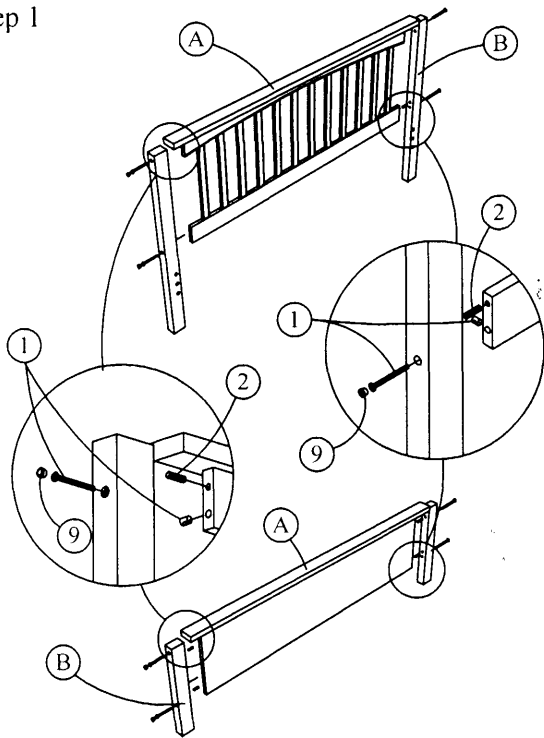

Assemble the bed frame headboard and footboard component as shown and tighten all bolt.

Step 2

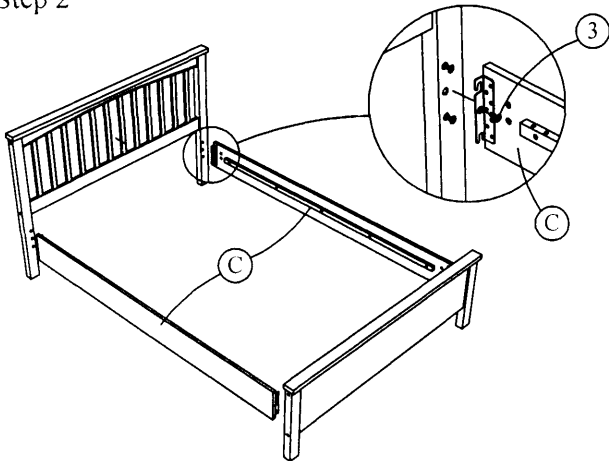

Hook the side rail to bolt as shown and don't tighten the bolt yet.

Step 3

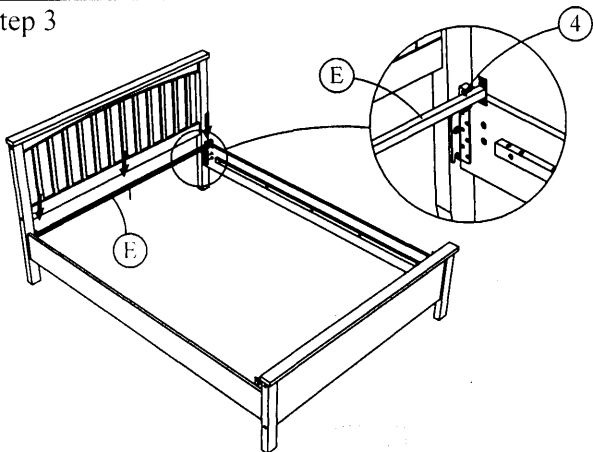

Put in cross bars and fix in bolt '4' as shown in diagram and tighten all bolts.

Step 4

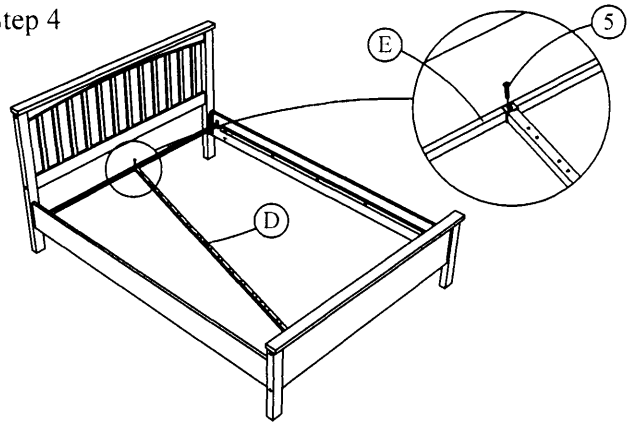

Fix center bar 'D' to cross bar 'E' by follow like diagram as shown.

Step 5

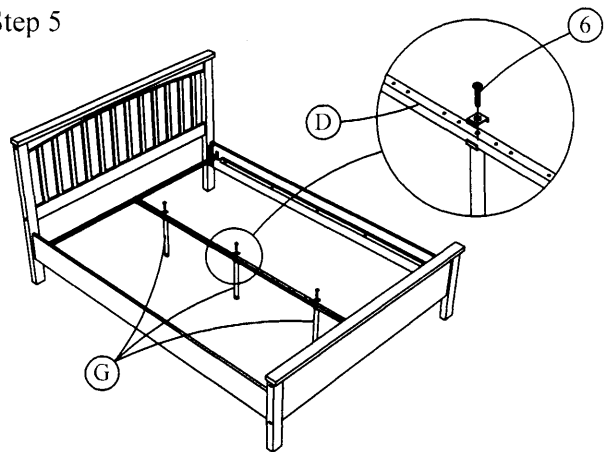

Fix in support leg with bolt 'G' as shown.

Step 6

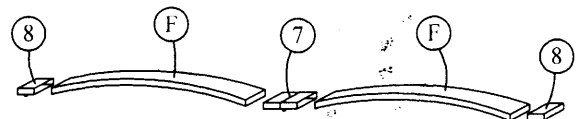



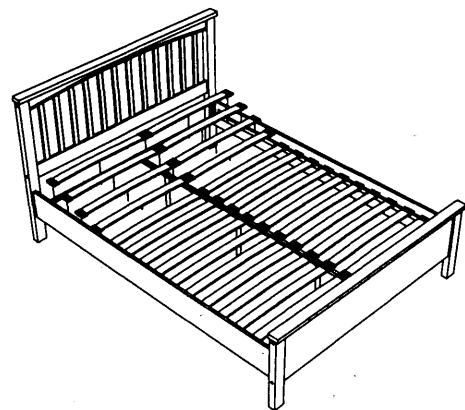







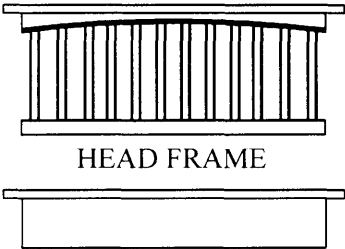
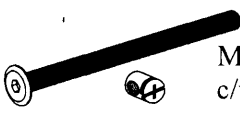
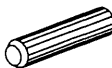

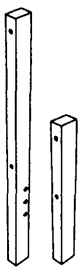

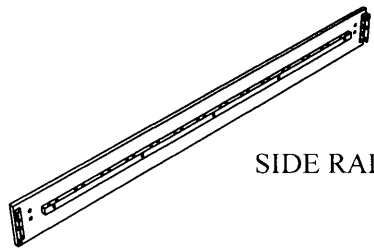
Each wood slat must be inserted with a single end plastic cap and a double end plastic cap as shown on the picture.

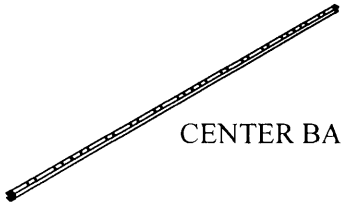

Once both wood slats have been inserted with the plastic caps, fix it on the wood side rails and center bar by pressing it accordingly to the default holes. Ensure the plastic cap's pin is aimed to the hole. At last make sure all screws and bolts are tighten.

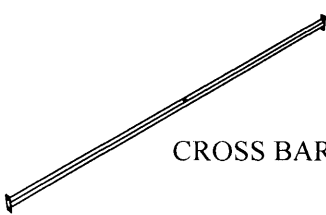
Please follow our assembly instruction procedure for easier assemble.

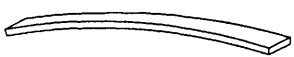
PARTS & HARDWARE LIST FOR 45-7422L-EM-MSR-75

NO	PART	QTY	NO	HARDWARE	QTY
A	 HEAD FRAME FOOT FRAME	1 pc	1	 M6x90mm c/w Barrel Nut	8 pcs
		1 pc	2	 Wood Dowel	8 pcs
			3	 M8x25mm	12 pcs
B	 HEAD POST - L/R FOOT POST - L/R	2 pcs	4	 M6x15mm	8 pcs
		2 pcs	5	 M6x30mm	2 pcs
C	 SIDE RAIL	2 pcs	6	 M8x40mm (assembled)	3 pcs
			7	 Double end plastic cap	12 pcs
			8	 Single end plastic cap	24 pcs
D	 CENTER BAR	1 pc	9	 Wood Button	8 pcs
E	 CROSS BAR	2 pcs	10	 M8- Allen key	1 pc
F	 WOOD SLAT	24 pcs	11	 M6- Allen key	1 pc
G	 SUPPORT LEG	3 pcs			