



# MODULAR MOTOR DRIVEN PUMPS 999000 SERIES

For Oil or Grease.

999000

ENGLISH

## PRODUCT DATA SHEET

### DESCRIPTION:

Modular pumps particularly suitable for the lubrication of small or medium size machinery. They are used for different types of oil and grease lubrication systems and in a very large range of applications because of their high quality, high performance and low cost.

The modular construction of 999 series pumps enables easy dismantling for maintenance, guarantees very high reliability and allows very fast adjustment of the units for different operating conditions.

### Basic modules:

Electric Motor.

Reduction Unit.

Single or Double Pumping Unit.

Reservoir.

Steel sheet reservoirs are equipped with low level indicator and electric contact. Reservoirs for oil are equipped with re-filling filter.



### ORDERING INFORMATION:

Type of motor and R.P.M.*	Adjustable delivery				Max. Press. bar (psi.)	Part No. of Motor Driven Pump 999000 Series Metal Reservoirs Capacity								Transparent Res. Capacity Grease Max NLGI 0	
	Cm <sup>3</sup> /min		Cu.in./min.			Grease Max. NLGI 3.				Oil Viscosity Min. 15 cSt					
	Min.	Max.	Min.	Max.		3Kg. 6.6lbs.	5Kg. 11lb.	10Kg. 22lb.	30Kg. 66lb.	3 Lt.	5 Lt.	10 Lt.	30 Lt.	3Kg. 6.6lb.	5Kg. 11lb.
A.C. 1500 R.P.M.	1,4	8,5	,08	,6	750 (11000)	999234	999214	999224	999204	999244	999264	999274	999254	999414	999424
	2,5	17	,15	1	400 (5800)	999236	999216	999226	999206	999246	999266	999276	999256	999416	999426
	5	33	,30	2	200 (2900)	999232	999212	999222	999202	999242	999262	999272	999252	999412	999428
D.C. 24V 2200 R.P.M.	2	14,5	,12	,9	750 (11000)	999634	999614	999624	999604	999644	999664	999674	999654	999684	999694
	3,6	25,5	,22	1,5	400 (5800)	999636	999616	999626	999606	999646	999666	999676	999656	999686	999696
	7,2	51	,44	3	200 (2900)	999632	999612	999622	999602	999642	999662	999672	999652	999682	999698
A.C. 1500 R.P.M.	Fixed delivery														
	8,5		,6		750 (11000)	999334	999314	999324	999304	999344	999376	999374	999354	999514	999524
	17		1		400 (5800)	999336	999336	999326	999306	999346	999366	999364	999356	999516	999526
33		2		200 (2900)	999332	999312	999322	999302	999342	999362	999372	999352	999512	999522	
D.C. 24V 2200 R.P.M.	14,5		,9		750 (11000)	999734	999395	999724	999704	999744	999764	999774	999754	999784	999794
	25,5		1,5		400 (5800)	999736	999712	999726	999706	999746	999776	999776	999756	999786	999796
	51		3		200 (2900)	999732	999716	999722	999702	999742	999762	999772	999782	999782	999792
D.C. 12V 2200 R.P.M.	14,5		,9		350 (5075)	999380	-	-	-	999390	-	-	-	999385	-
						Grease Max. NLGI 0				Oil Viscosity Min.				Grease Max. NLGI 0	

R.P.M.\* and lubricant deliveries indicated in the table refer to 50Hz. motors. With 60Hz. motors speeds and deliveries are increased by 20%.

## SPECIFICATION:

**Operating pressure:** up 75Mpa  
(750 bar) (11000 psi.)

**Delivery:**  
**Fixed.** up to 33 cm<sup>3</sup>/min- 1500 r.p.m.  
**Adjustable.** up to 51cm<sup>3</sup>/min. - 2200 r.p.m.

**Lubricant:** Oil viscosity 15 cSt min.  
Grease NLGI 2\*

\* at the operating lubricant temperature between -20°C to +100°C

## MOTORS:

### A.C. Motors:

Code 3301137 Three phase 220/380V - 50Hz - 0.12kW

Code 3301269 Single phase 220V - 50Hz - 0.12kW

### D.C. Motors:

Code 3301283 24V 120W

Code 3301274 12V - 100W

Specify voltage frequency and phase when ordering.

## INSTALLATION/OPERATION:

### Hydraulic diagram.

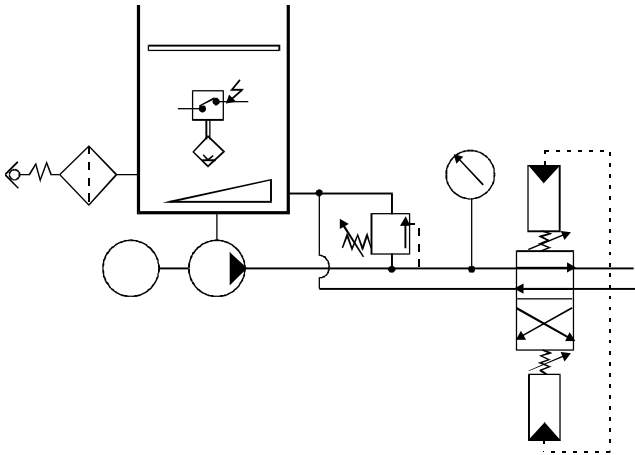

### Dimensions.

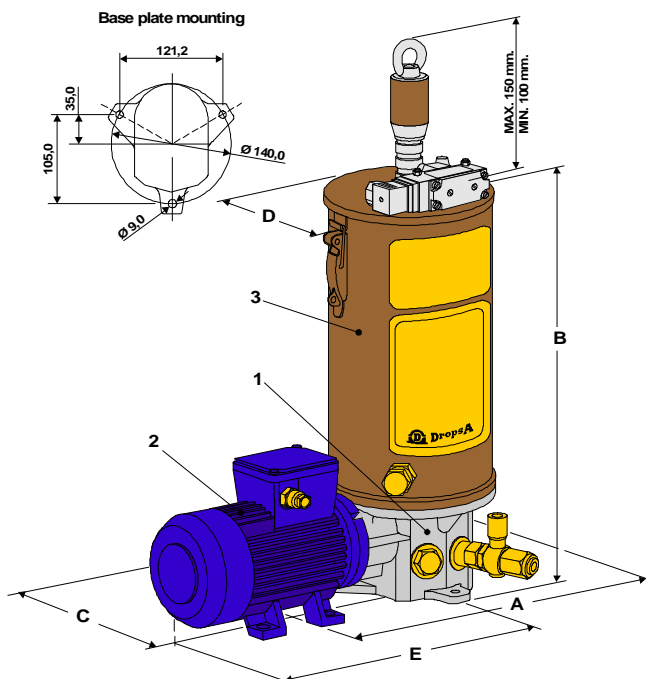

Pump	Dimensions mm.				
	A	B	C	D	E
3	390	340,5	220	Ø160	292
5	390	400,5	220	Ø160	292
10	442	505	220	Ø262	292
30	472	673	220	Ø262	292

## ACCESSORIES:

### Auxiliary Pumping Unit.

Pumps are supplied with one pumping unit but are designed for the mounting of two pumping units. This allows a feed to two separate lines or the outlets of the pumping units may be combined to provided double the delivery to a single line.

Part numbers of second pumping units are given in the table below.

Last digit of	Features of 999 pump			Second pumping unit	
	Delivery cm <sup>3</sup> /min.		Pressure	Part No./delivery	
	Adjust	Fixed		Adjust	Fixed
4	1,4-9,5	9,5	750	<b>299041</b>	<b>299039</b>
6	2,5-17	17	400	<b>299042</b>	<b>299040</b>
2	5-33	33	200	<b>299042</b>	<b>299040</b>

### Re-filling Filter. (for grease reservoir)

Removable filter cartridge, to prevent contaminates and foreign bodies from entering the reservoir and to prevent air bubbles forming in the grease..

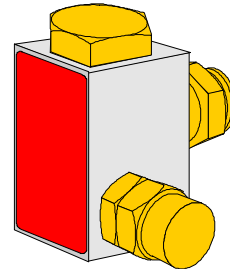

**Part No. 299352** for metal reservoirs.

**Part No. 299353** for transparent reservoirs.

Thread G ½ A UNI-ISO 228/1. Cartridge (150 micron)

**Part No. 1113006.** The filter is provided with thread Rp ¼ UNI-ISO 7/1 for the return line into the reservoir.

### Safety By-pass Valve.

Available for different pressure ranges this adjustable valve can be fitted on the outlet line. It protects the system from over pressure.



Part No.	Pressure range.
<b>299450</b>	0 to 250 bar (0 to 3600 psi.).
<b>299451</b>	0 to 450 bar (0 to 6500 psi.).
<b>299452</b>	50 to 1000 bar (725 to 14500 psi.).

### Max. Electric Level Contact.

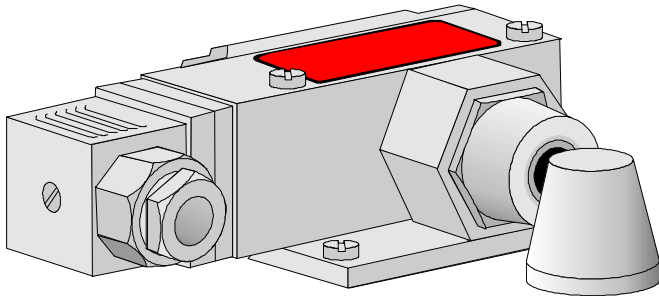

All metal reservoirs (except 3 and 5 litres) can be equipped with a Max. electric level contact for automatic re-filling of the reservoir.  
Reservoirs for grease.

Electric contact **Part No. 299197.**  
Reservoirs for oil.  
Electric contact **Part No. 291155.**

### Pressure Gauge.

Available for different pressure ranges.

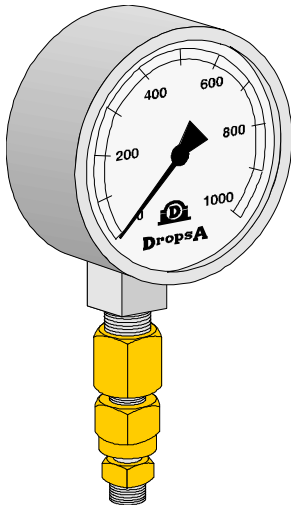

**Part No. 299196** 0 to 500 bar.  
**Part No. 291395** 0 to 1000 bar.

### Assembly Kit.

999 series pumps can be equipped with a kit consisting of: Re-filling Filter; Pressure Gauge; Safety By-pass Valve and Base Plate. To order the Assembly Kit see the table below.

Last digit of pump Part No.	Assembly Kit with By-pass Valve	
	1 Pumping unit	2 Pumping Units
4	<b>299462</b>	<b>299463</b>
6	<b>299462</b>	<b>299463</b>
2	<b>299474</b>	<b>299475</b>

### Change Over Valve (Inverter).

For use with Dual Line Systems. An adjustable change over valve (automatic change over when the pressure exceeds a fixed value) available in the following types:

### Hydraulic Inverter.

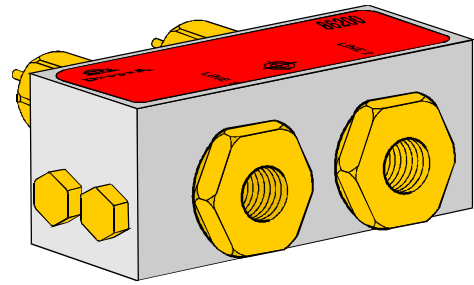

It controls automatically the lines' pressurisation inversion when the pressure value set on the adjusting valve is reached.

**Part No. 86198** for pressures up to 50 bar.  
**Part No. 86199** for pressures up to 300 bar.  
**Part No. 86200** for pressures up to 200 bar.

### Electro/pneumatic Inverter.

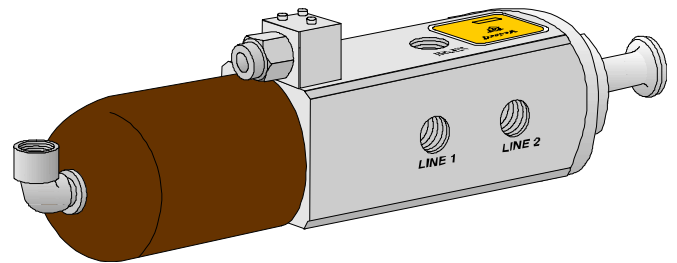

It controls the lines' pressurisation inversion through a solenoid valve connected to the system's electrical equipment and to the end of line pressure switch.

**For pressures up to 500 bar.**  
**Part No. 83300** with electric valve 110V – 50Hz.  
**Part No. 83304** with electric valve 220V – 50Hz.  
**Part No. 83308** with electric valve 24V – 50Hz.  
**Part No. 83309** with electric valve 24V d.c.

### Pneumatic Inverter.

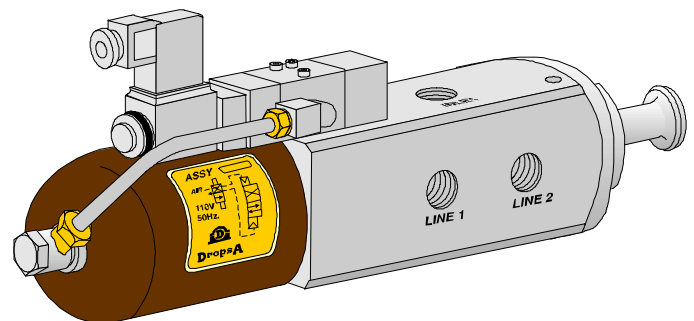

Similar to the electro-pneumatic inverter but without solenoid valve; it is operated through a pneumatically driven control directly from customer's equipment.  
**Part No. 83301**

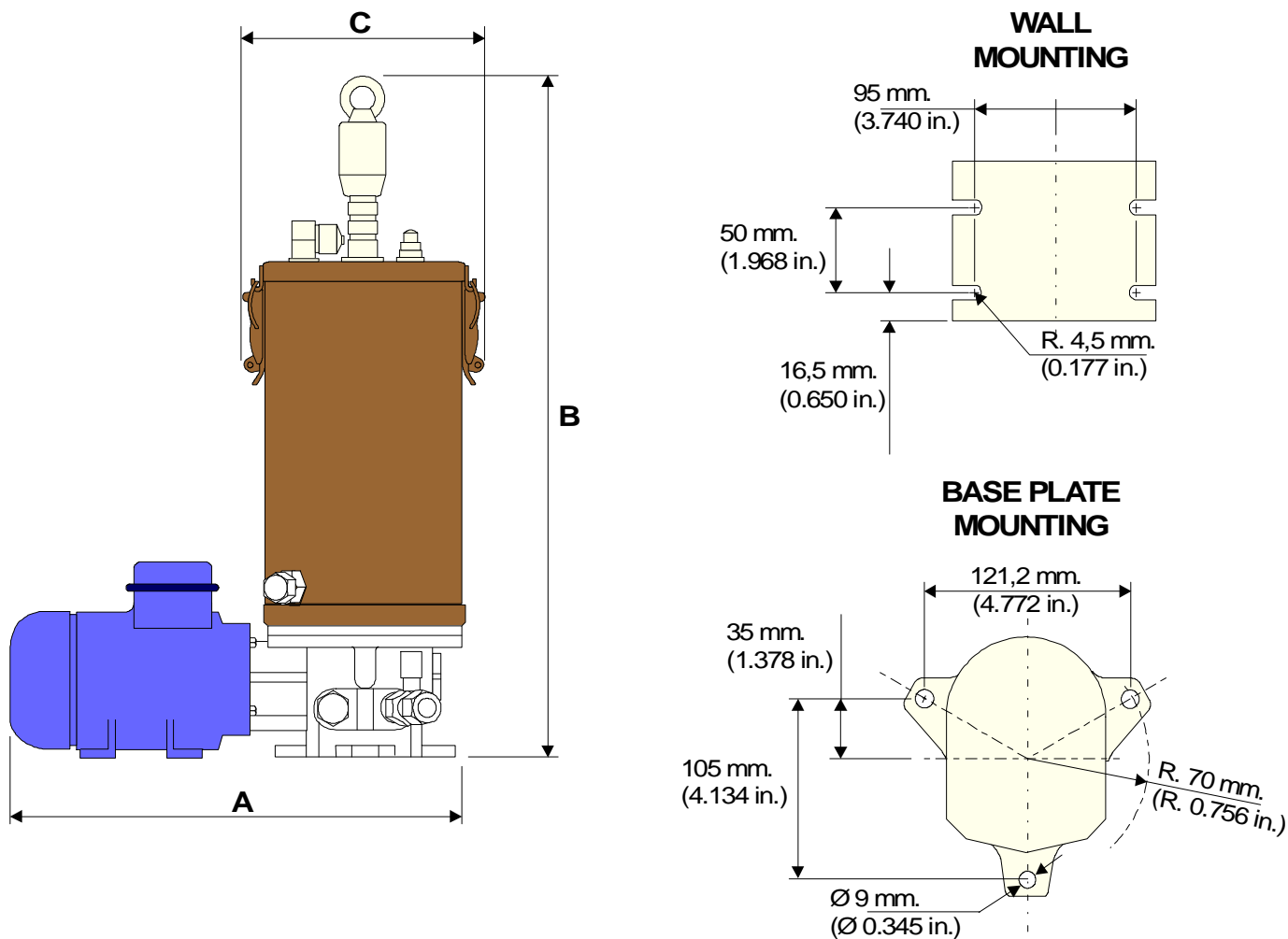

**OVERALL DIMENSIONS:**

D i m	Grease Reservoir										Oil Reservoir											
	3 Kg. (6.6 lbs.)				5 Kg. (11 lbs.)						10 Kg. (22 lbs.)		30 Kg. (66 lbs.)		3 litres (.8 US gal.)		5 litres (1.3 US gal.)		10 litres (2.6 US gal.)		30 litres (8 US gal.)	
	Trans.		Metal		Trans.		Metal															
	mm.	In.	mm.	In.	mm.	In.	mm.	In.	mm.	In.	mm.	In.	mm.	In.	mm.	In.	mm.	In.	mm.	In.		
A	300	11.8	300	11.8	300	11.8	300	11.8	423	16.6	453	17.8	300	11.8	300	11.8	423	16.6	453	17.8		
B	354	13.9	490	19.3	414	16.3	550	21.6	645	25.4	825	32.5	392	15.4	452	17.8	557	21.9	714	28.1		
CØ	197	7.8	197	7.8	197	7.8	197	7.8	299	11.8	358	14.1	197	7.8	197	7.8	299	11.8	358	14.1		



**LUBE Control**

**Lube Control Pty Ltd**  
*Providing lubrication solutions!*

Unit 5/53 Norfolk Rd,  
Marion, SA 5043  
[www.lubecontrol.com.au](http://www.lubecontrol.com.au)

t: (08) 8298 5563  
f: (08) 8298 6253  
e: [info@lubecontrol.com.au](mailto:info@lubecontrol.com.au)

**U.K.**  
Dropsa (UK) Ltd.  
Unit 6, Egham Business Village,  
Egham,  
Surrey, TW20 8RB  
Tel: (+44) 01784 - 431177  
Fax: (+44) 01784 - 438598  
E-mail: [salesuk@dropsa.com](mailto:salesuk@dropsa.com)

**U.S.A.**  
Dropsa USA Inc.  
50679 Wing Drive  
Utica,  
Michigan 48315,  
Tel: (+1) 810-566-1540  
Fax: (+1) 810-566-1541  
E-mail: [salesusa@dropsa.com](mailto:salesusa@dropsa.com)

**AUSTRALIA**  
Dropsa Australia Pty.  
No. 7 Warringah Road  
Dee Why  
NSW 2099  
Tel: (+61) 2 9905 0410  
Fax: (+61) 2 99394142  
E-mail: [sales@dropsa.com](mailto:sales@dropsa.com)

**GERMANY**  
Dropsa GmbH.  
Volmerswerther Strasse 80  
40221 Dusseldorf 1,  
Deutschland  
Tel: (+49) 0211-394-011  
Fax: (+49) 0211-394-013  
E-mail: [sales@dropsa.de](mailto:sales@dropsa.de)

**ITALY**  
Dropsa Spa  
Via B. Croce,1 - 20090  
Vimodrone (MI)  
Tel: (+39) 02 - 250.79.1  
Fax: (+39) 02 - 250.79.767  
E-mail: [sales@dropsa.it](mailto:sales@dropsa.it) (Export)  
E-mail: [vendite@dropsa.it](mailto:vendite@dropsa.it) (National)

Copyright Dropsa - all rights reserved. Reproduction of any part of this document is strictly forbidden without prior consent from Dropsa. Dropsa reserves the right to modify specifications without prior notice.